

N. CHAPMAN.
Loom-Temple.

No. 162,744.

Patented May 4, 1875.

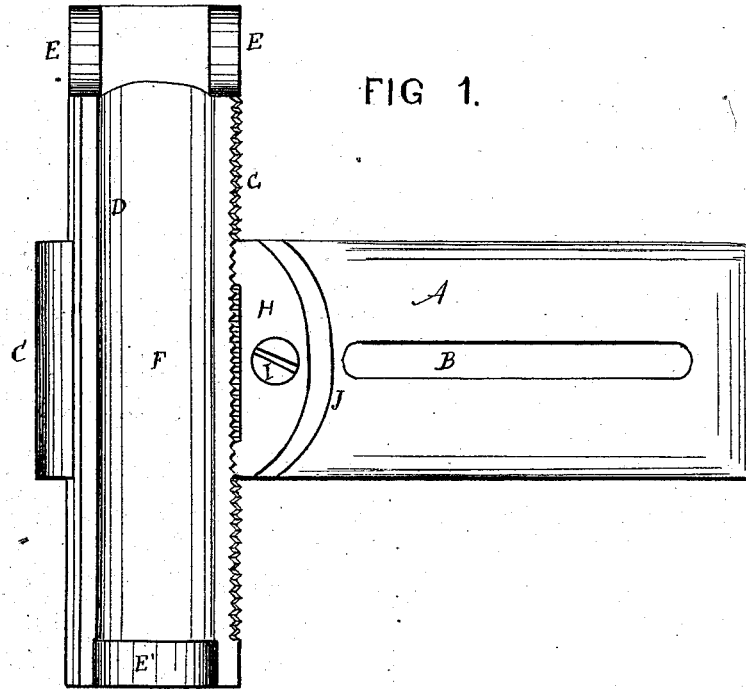

FIG 1.

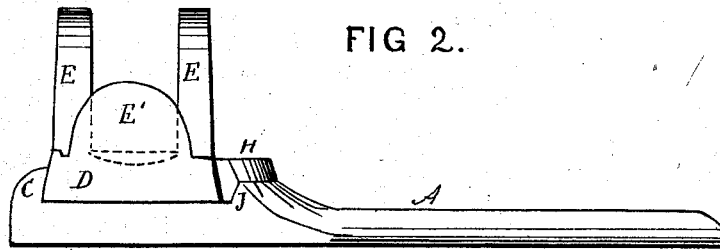

FIG 2.

WITNESSES.
J. E. Dennis
Geo. D. Patton

FIG 3.



Nathan Chapman
By his Atty. *J. Dennis Jr*

UNITED STATES PATENT OFFICE.

NATHAN CHAPMAN, OF HOPEDALE, MASSACHUSETTS.

IMPROVEMENT IN LOOM-TEMPLES.

Specification forming part of Letters Patent No. **162,744**, dated May 4, 1875; application filed January 9, 1875.

To all whom it may concern:

Be it known that I, NATHAN CHAPMAN, of Hopedale, Worcester county, in the State of Massachusetts, have invented certain new and useful Improvements in Stands for Loom-Temples; and I do hereby declare the following to be a full and exact description thereof, reference being had to the accompanying drawings forming part of this specification.

The nature or essence of my invention consists in a stand to be fastened to the loom, and provided with a flange and notched plate, in combination with a stand, to hold the temple, provided with a notched side to fit the notches in the plate that clamps it and holds it in place.

Figure 1 is a plan of the two stands and plate as applied to use. Fig. 2 is an elevation of the same. Fig. 3 shows the under side of the clamping-plate.

In the accompanying drawings, A is a stand, fastened to the breast-beam of the loom by a screw through the slot B, to hold it fast. On the opposite end of the stand A from the slot there is a flange, C, inclined inward to fit the inclined side of the stand D, which is made in the form shown, to receive the loom-temple described in the patent, No. 154,837, granted me September 8, 1874. This stand D is provided with two lugs, E E, at the front, and

between which the shank of the temple traverses, and one lug, E', on the rear end, for a rod, which holds a spring in the groove F, to press the temple forward. The notched side G of the stand D is also inclined, and the clamping-plate H is also inclined, to form a dovetailing space with the flange C, to hold the stand D, and allow it to be adjusted either way, as desired. The plate H is notched to fit the notched side of the stand D, and prevent it from slipping when the plate H is drawn down by the screw I to clamp the stand. The rear side of the plate H is curved and beveled to fit a curved and beveled flange, J, on the stand A, so that as the plate is drawn down the beveled surfaces press the plate against the stand and hold it fast. The screw I passes through a slot in the plate H, and screws into the stand A.

What I claim as my invention is—

The loom-temple stand A, provided with a flange, C, curved flange J, and the curved and notched wedge-plate H, in combination with the stand D, having a notched side to correspond with the notched plate H, as described, for the purpose set forth.

NATHAN CHAPMAN.

Witnesses:

N. E. CHAPMAN,
LEANDER HOLBROOK.