

L. J. MARCY.
Magic Lantern.

No. 162,759.

Patented May 4, 1875.

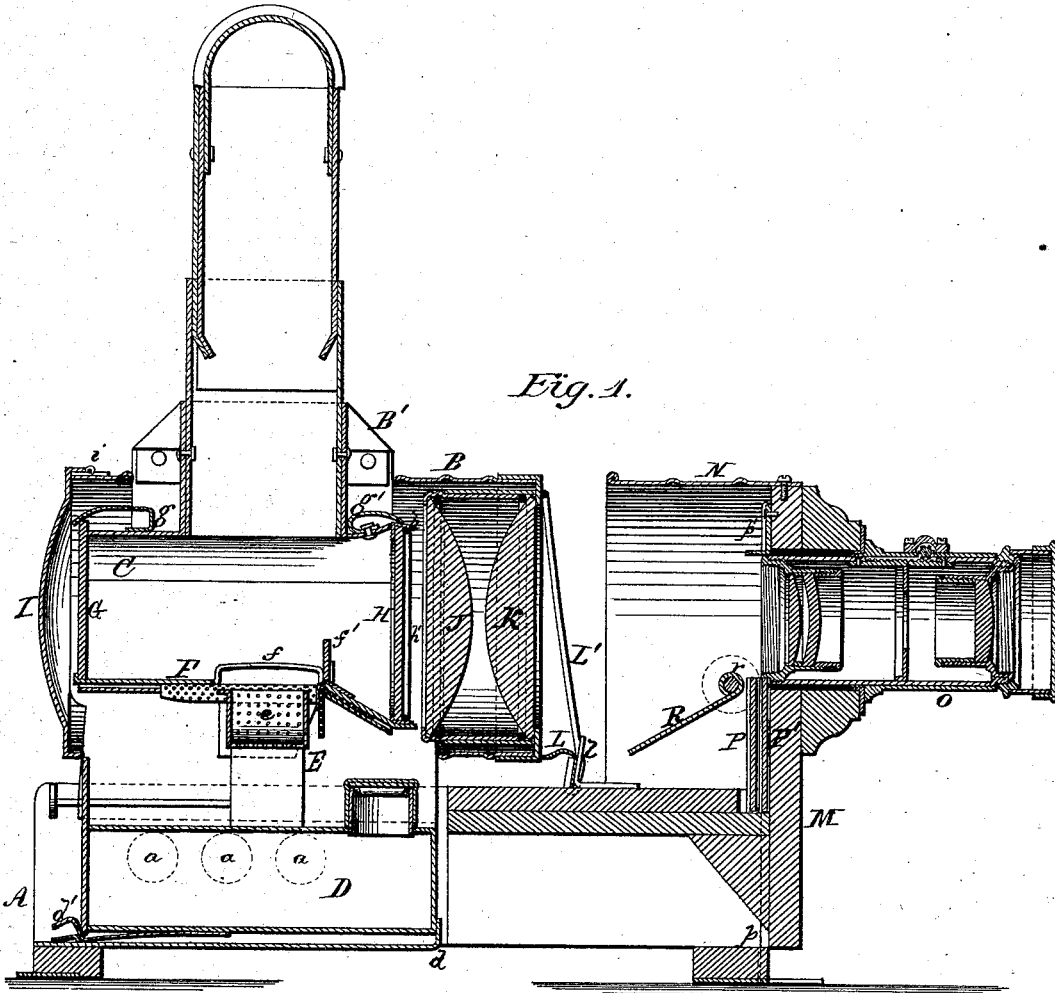

Fig. 1.

Witnesses;
 E. Davidson
 B. H. Morse

Inventor;
 L. J. Marcy
 by his Atty
 W. D. Baldwin

L. J. MARCY.
Magic Lantern.

No. 162,759.

Patented May 4, 1875.

Fig. 2.

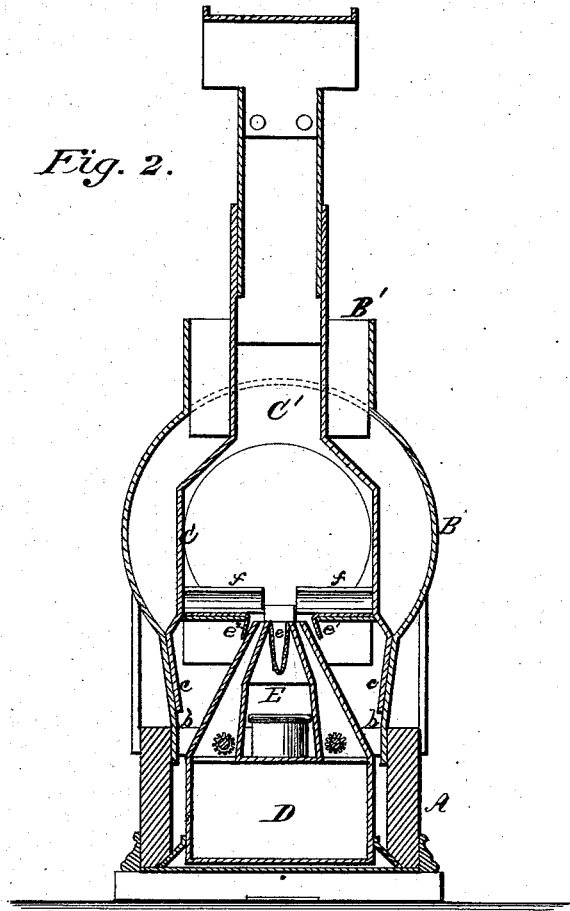

Witnesses;
C. Davidson
B. H. Morse

Inventor;
L. J. Marcy
by his Atty
W. W. Baldwin

UNITED STATES PATENT OFFICE.

LORENZO J. MARCY, OF PHILADELPHIA, PENNSYLVANIA.

IMPROVEMENT IN MAGIC LANTERNS.

Specification forming part of Letters Patent No. **162,759**, dated May 4, 1875; application filed May 31, 1873.

To all whom it may concern:

Be it known that I, LORENZO JAMES MARCY, of Philadelphia, Pennsylvania, have invented certain Improvements in Magic Lanterns, of which the following is a specification:

The inventions herein set forth constitute improvements on the magic lantern heretofore patented to me April 28, 1868, and July 6, 1869. Obviously, however, some of these improvements may be used without the others, and in lanterns differing in their details from the construction therein shown.

The object of the first part of my invention is to enable the operator to vary the coloring and shading of the pictures, and this I do by combining with the lantern slides of colored glass to be moved across the line of light. I also use an opaque flap to darken the field. My inventions further relate to improvements on the lamp, on the means for holding the lenses, and on the devices for protecting the front glass of the frame-chamber from the heat of the lamp. The nature, scope, and subject-matter of these improvements are hereinafter fully set forth.

In the accompanying drawings of my improved apparatus, Figure 1 shows a vertical longitudinal section, and Fig. 2 a similar transverse one thereof.

A box-shaped base, A, having air-holes *a* in its sides, supports a tubular outer case, B, by means of connecting side flaps *b*, as set forth in my patent of July 6, 1869. The inner case C is secured near its bottom to the outer one by narrow side strips *c*, to leave room for the air to circulate between the two cases. An open box, B', forms a part of the outer case. The chimney C' of the inner case is flatter and narrower than this box through which it passes, and the two are riveted together, as in Fig. 1. The sides of the box project in front and rear of the chimney, and a space is left between the outer case and the ends of the box, so that air may pass up freely between the two cases, and between the box and chimney, as well as between the box and outer case, thus cooling the lantern. The lamp D slides in ways in the open-ended lamp-chamber, as described in my patent of 1869, abutting against a stop, *d*, at its front end, and being locked by a spring-stop, *d'*, behind it.

As the lamp fits snugly in its ways it is thus held steadily in its proper relation to the slotted diaphragm F. The details of the burner differ somewhat from that shown in my patent of 1869, although the principles of construction therein set forth are retained. The top E of the burner is made of a rectangular pyramidal shape to adapt it to the reception of flat wicks. A guard, *e*, of wire-gauze, in the shape of a V, is placed between the burners, which fit within flanges *e*¹ *e*², covering the cavity of the struck-up portion *f* of the slotted diaphragm F. The purpose of these guards is freely to admit air to the flame, and yet to prevent flickering. An upright narrow strip, *f'*, of glass, in front of the rib *f*, serves to protect the front glass of the flame-chamber from heat. The ends of the inner case or flame-chamber are closed by glasses G H, held in place by spring-catches *g g'*. The reflector I is pivoted to the outer case by a hinge, *i*, so that it may be turned up out of the way when access is desired to the flame-chamber, and yet, being connected with the case, is not liable to be dropped or misplaced. The rear glass G of the flame-chamber is a simple plate, its office being merely to close the end of the chamber against drafts. Air, however, passes up between it and the reflector. The front glass H, being necessarily nearer the flame, is exposed to greater heat than the rear one, and is liable to be cracked. To prevent its dropping out of position in such case I mount the glass in a frame, *h*, of sheet metal, having its edges turned up to form springs. The glass is placed in this frame and clamped by a circular spring, *h'*, of wire, which slips inside the flanges. A cracked glass can thus be held in place or easily replaced by a sound one. An air-space, it will be observed, is left between this glass and the condensing-lenses J K, which latter need no description.

A slide-rest, L, is secured to the base in front of these lenses, being held in place by a pin and spring-catch, *l*, somewhat similar to those shown in my former patents. A simple holding-spring, L', is, however, substituted for the slide-frame shown in those patents.

The objective tube O and its shield N are mounted on a frame, M, sliding in ways in the base A, so that these parts may be adjusted

relatively to the lantern proper as desired. The objective tube is made in two sections, connected by a telescopic joint, and movable, one upon the other, by a rack and pinion. Each section carries a proper lens or lenses, united to it by screw-couplings in such manner as readily to admit of their removal or insertion. The details of this part of the apparatus, being familiar to opticians, need not be described.

In order to produce the effects of clouds or coloring I employ a shade or shades, arranged to slide vertically in ways or guides on the objective-tube frame, and operated by a suitable handle or lever. Fig. 1 shows two such slides, P P', one being intended for red, the other for blue, glass. These slides are controlled, in this instance, by guide rods *p*, passing downward through holes in the frame, and by lifting-rods *p''*, extending upward through the shield N.

As the glass is drawn up the coloring descends on the picture, its apparent movement being reversed by the lenses, and the effect produced is much more natural than that of a flap of colored glass hinged above, and swinging down over, the tube, as has been proposed.

In order to darken the field I hinge an opaque flap, R, so that it may be rocked on a pivot, *r*, in the shield. As this flap swings up from below it produces the effect of a pall or curtain descending over the picture, instead of rising or moving laterally over it, as has heretofore been the case.

The flaps R and slides P P', it will be observed, are inclosed entirely within the shield or hood, and are thus protected from injury, and much more convenient to reach than when mounted on the front end of the objective tube.

The functions and mode of operation of the different devices will readily be understood from the foregoing description.

I claim—

1. In a magic lantern, a color-glass, constructed substantially as set forth, to slide up-

ward from below across the line of light, whereby the shade is caused to descend upon the picture, as set forth.

2. The combination, substantially as set forth, of objective lenses, their supporting-frame, and a color glass or shade reciprocating in guides in said frame outside of the focus of the lantern whereby the effect of clouding is produced upon the picture.

3. A hinged flap, constructed substantially as set forth, to swing upward from below across the line of light, with its edge within the focus of the lantern, whereby a sharp line, similar to that caused by a falling curtain, is produced when the flap is turned up to shut off the light from the objective tube.

4. The combination, substantially as set forth, of a lantern-body, an adjustable frame, in which the objective lenses are mounted, a hood attached to the adjustable frame, and a swinging flap hinged within, and protected by, said hood.

5. The combination, substantially as set forth, of a flame-chamber, a lamp-chamber, a slotted diaphragm separating the two chambers, a lamp the upper edge of which sits close to the diaphragm, and flanges on the diaphragm overlapping the top of the lamp, to secure a strong draft, while preventing flickering.

6. The combination, substantially as set forth, of the flame-chamber, the front glass, its spring-frame, and circular retaining-spring, whereby the glass, although accidentally cracked, may be retained in the frame.

7. The combination, substantially as set forth, of the lamp, the flame-chamber, its front glass, and the heat-deflector plate *f'*, arranged between the lamp and glass, whereby the front glass may be brought close to the lamp with little danger of cracking.

In testimony whereof I have hereunto subscribed my name.

L. J. MARCY.

Witnesses:

JOE I. PEYTON,
E. C. DAVIDSON.