

D. ARMSTRONG & J. A. HUTCHINSON.  
Machine for Finishing Horseshoe-Nails.

No. 162,789.

Patented May 4, 1875.

FIG. I.

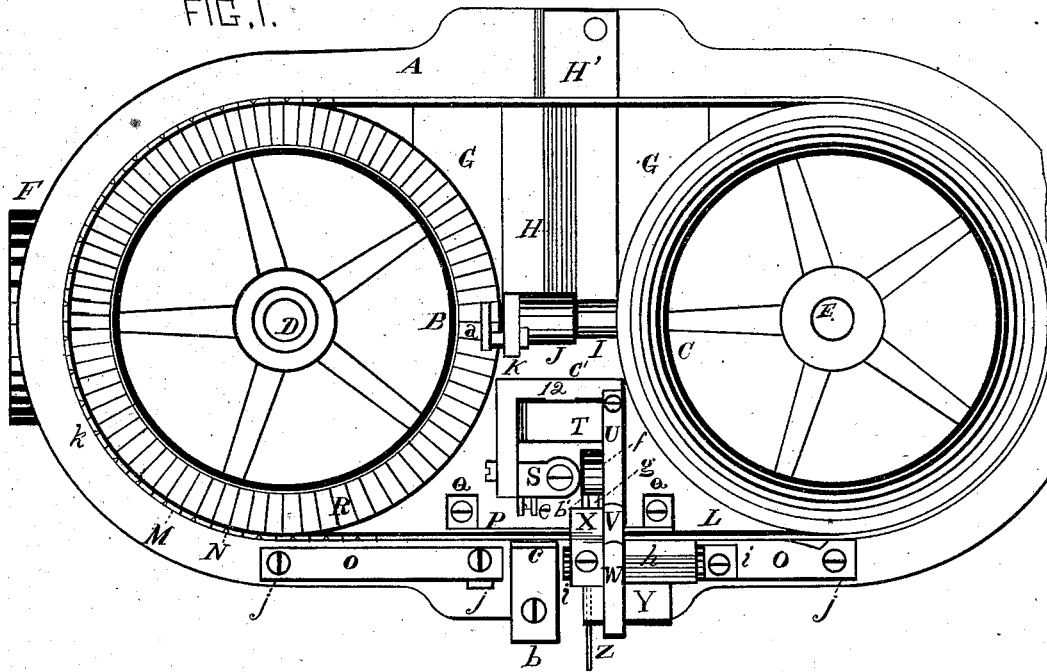
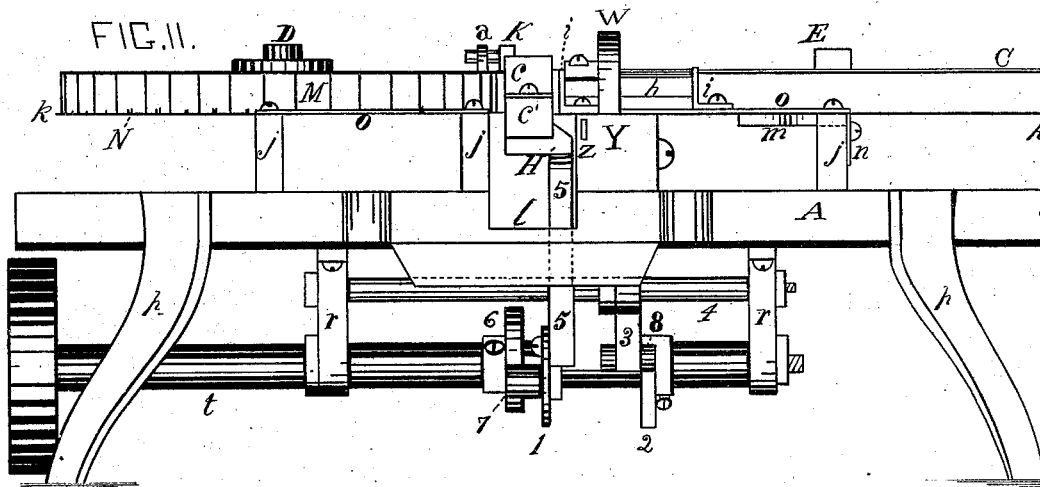

FIG. II.



WITNESSES

*Edward Dunston*  
*Ed Gardner*

INVENTORS

*Daniel Armstrong*  
*John A. Hutchinson*  
*By G. D. Chapin.*  
*Atty.*

D. ARMSTRONG & J. A. HUTCHINSON.  
Machine for Finishing Horseshoe-Nails.

No. 162,789.

Patented May 4, 1875.

FIG. III.

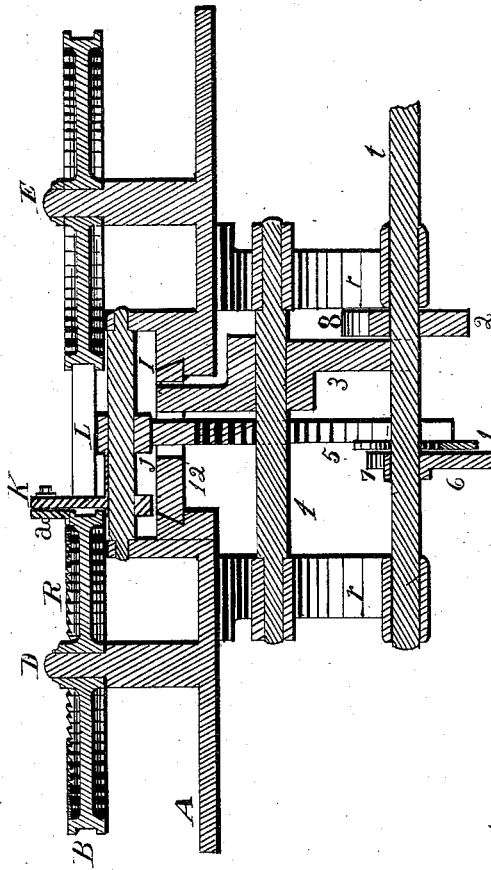

WITNESSES

*Edward Dunston*  
*Ed W Gardner*

INVENTORS.

*Daniel Armstrong*  
*John A. Hutchinson*  
*By G. D. Chapman*  
*Atty.*

D. ARMSTRONG & J. A. HUTCHINSON.  
Machine for Finishing Horseshoe-Nails:

No. 162,789.

Patented May 4, 1875.

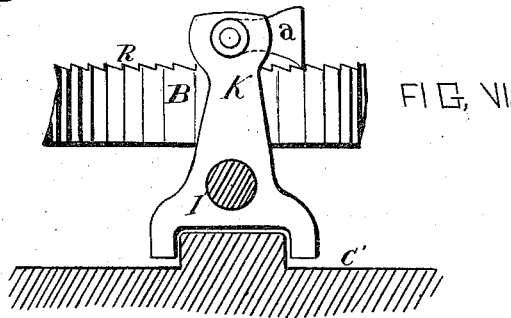
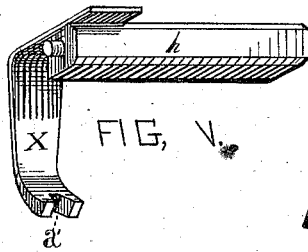
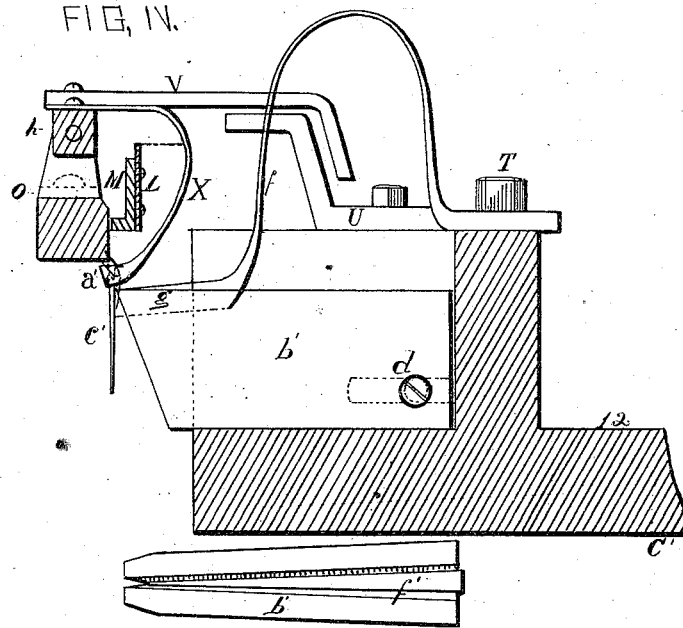

WITNESSES

*Edward Derstler*  
*Ed. Gardner*

INVENTORS

*Daniel Armstrong*  
*John A. Hutchinson*  
*By G. L. Chapin*  
*Atty.*

D. ARMSTRONG & J. A. HUTCHINSON.  
Machine for Finishing Horseshoe-Nails.

No. 162,789.

Patented May 4, 1875.

FIG. VII.

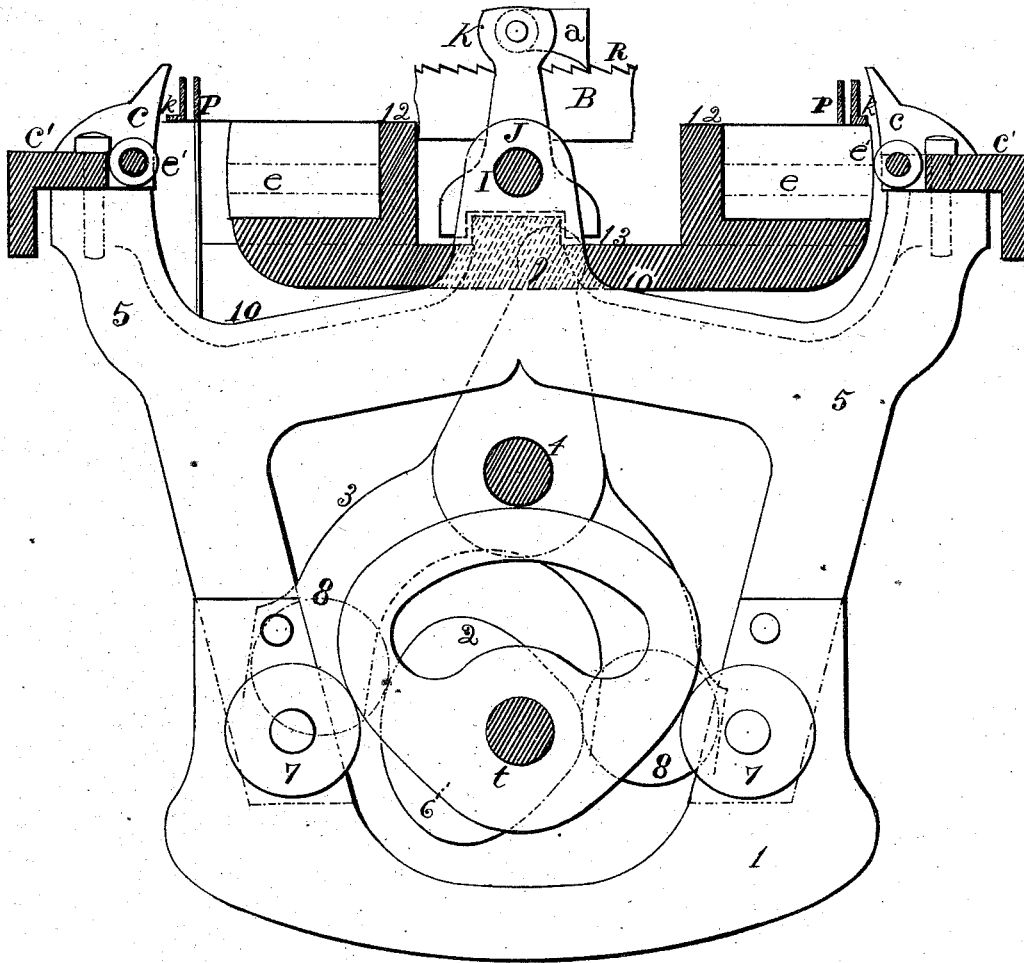
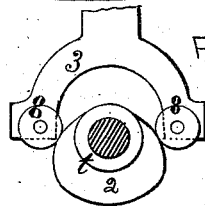

FIG. VIII.



WITNESSES

*Edw. Dunstan*  
*Ed. Gordon*

INVENTORS

*Donnel Armstrong*  
*John A. Hutchinson*  
*By J. P. Chapin*  
*Atty*

# UNITED STATES PATENT OFFICE.

DANIEL ARMSTRONG AND JOHN A. HUTCHINSON, OF CHICAGO, ILLINOIS.

## IMPROVEMENT IN MACHINES FOR FINISHING HORSESHOE-NAILS.

Specification forming part of Letters Patent No. 162,789, dated May 4, 1875; application filed January 27, 1875.

*To all whom it may concern:*

Be it known that we, DANIEL ARMSTRONG and JOHN A. HUTCHINSON, of Chicago, in the county of Cook and State of Illinois, have invented a new and useful Improvement in Machines for Finishing Horseshoe-Nails, of which the following is a specification:

The object of the present invention is to take horseshoe-nails as they are left by the forging-machine and finish them ready for driving—that is, to straighten, smooth, and point them; also, to finish horseshoe-nails which are cut.

The nature of the invention consists, first, in a carrying-belt, which is composed of a series of slotted or notched plates, secured to a steel belt, and arranged to receive the nails as they are fed by hand, and carry them to dies and rollers, by means of which they are drawn out and straightened, preparatory to being pointed by dies in a second operation; (the belt carrying the nail-holders or notched plates is driven by two wheels, round which it passes; and the wheels, by suitable gearing, are caused to stop during the action of the dies when rolling and pointing the nails;) second, in the novel construction and arrangement of rollers and dies, for drawing out and sizing the nails, as they are combined with mechanism to move the rollers on the arc of a circle, and to bring the dies to the roller at the time the carrying-belt is at rest; third, in combination with the carrying-belt, dies for pointing the nails when the belt is at rest; fourth, the novel construction of the pointing-dies, combined with springs or punches for holding the nails in place when being pointed, and discharging the nails when pointed; fifth, the novel construction of the feeding devices for moving the carrying-belt and driving the dies, as the whole is hereinafter fully described and shown.

In the drawings, Figure 1, Sheet 1, is a plan or top view of a machine embodying our improvements for finishing horseshoe-nails; Fig. 2, a side elevation thereof; Fig. 3, Sheet 2, a longitudinal section of the machine, showing a modification of the proportions of some of the operating parts; Fig. 4, Sheet 3, is a central cross-section of half the machine enlarged three diameters from the views shown in Figs. 1, 2, and 3, to give a clear view of the construc-

tion; Fig. 5, an enlarged perspective view of rock-shaft and the nail holder; Fig. 6, an enlarged view of the feed-clutch in position relative to its working parts; Fig. 7, Sheet 4, a cross-section of the machine, of a size corresponding to Fig. 4. Fig. 8 shows an elevation of one of the cams and its yoke, of a size corresponding to Fig. 3.

A represents a substantial frame, made of iron or other suitable material, of the form shown, or such other form as may be convenient to support the mechanism hereinafter described, legs *pp* being used to support it in the ordinary manner. B represents a feed-wheel, which is supported by a shaft, D, having bearings or a bearing in the frame A beneath, and which is provided with such a number of notches, R, as shown, that a pawl, *a*, may put it in motion to carry a belt, L. C represents a wheel, corresponding in size to the wheel B, hung to a shaft, E, which is also provided with a bearing in the frame A. The peripheries of these wheels are provided with grooves for carrying a steel belt, L, which in this case is provided with continuous carriers M to receive the nails as they are fed by hand or otherwise. The lower ends of these carriers are turned out horizontally, and provided with notches N, in which the nails are put. The belt L, however, may be provided with notches, so as to answer the same purpose. *rr* represent hangers, which are secured to the frame A, and support a main drive-shaft, *t*. This shaft supports cams 6 and 2, for operating their respective yokes 1, 5 and 3, anti-friction rollers 7 and 8 being used to secure the easy movements of the parts. The yoke 3 is hung to a stationary shaft, 4, and its upper end fits into the bed C' of a sliding carriage, which is arranged to have a reciprocating movement in that part of the frame A shown at G G, when the yoke is put in motion by the cam 2.

The yoke 1, 5 is hung to a shaft, I, as shown at J, that it may have an oscillating movement. 12 represents a frame, attached to the bed C' of the carriage, and in it are fastened dies *e e*, for holding the nails when being drawn out and formed by rollers *e e'*, pivoted to the upper ends *e* of the yoke 1, 5, and dies *b'*, for pointing the nails. Z represents a punch, secured to a substantial casting, Y, and used,

in combination with the die *b'*, for cutting the points of nails. *h* represents a rock-shaft, which is pivoted to ears *i i*, fastened to guide-plates *o o*, and has attached to it a curved plate, *v*, and a nail-holder, *X*; and it has given to it an oscillating movement by a cam, *U*, passing under the plate *v* when the carriage *C'* moves forward, and by a spring, *W*, bearing on the plate *V*. A nail-holder, *X*, is fastened to the rock-shaft *h*, and its lower end *a'* is curved under the belt *L*, and provided with a notch, *a'*, Fig. 5, to catch the nails and center them on the punch *Z*, and thus hold them in position to have their points cut evenly on both sides. *f* represents a spring, secured to the frame 12 by means of a clamp, *T*. Its end *g* extends into the jaws of the die *b'*, and as it is moved forward by the carriage *C'* it clamps the nails against the punch *Z*, and draws the nails down in the carriers *M N*, that they may all be cut of uniform length. When the die *b'* moves back, the point *g* of the spring *f*, being pressed against the nails, prevents their sticking in the die, so as to be removed from the carriers *M N* by a blade, *m*, fastened to a standard, *j*.

The operation of the straightening devices is as follows: The nails are, in this machine, fed by hand into the notches *N* of carriers *M*, between the guards *O* and belt *L*. When a nail comes opposite the die *e* the belt stops, and the yoke 3 moves the die *e* forward to the nail, and holds it there until the roller *e'* passes down on the face of the nail and shapes it. The die then moves back, allowing the nail to be carried to the pointer by the belt, where the pointing is done, as above described.

The feed-wheel *B* is operated as follows: A projection is formed on the top of the part *C'*, so as to give an oscillating movement to a lever, *K''*, to which is pivoted a pawl, *a*, operating in the notches *R*.

Beveling-dies may be attached to the machine, and a scraper or scrapers may be attached, so as to work automatically, and scrape or cut off the burrs turned by the pointing devices. The carriage *C'* may be used as a means for operating the scraper and beveling-dies.

The rolling-die *e* is made of three pieces of steel, as shown, the jaws projecting beyond the center part the thickness of the nail, by means of which they can be faced on a stone with little labor. The pointing-die *b'*, as shown in Fig. 4, is formed of two pieces, held apart by a wedge, *f*. It is to be sharpened by grinding the narrow piece, and kept in shape by adjusting the wedge. *e'* represents a nail in position to be pointed, Fig. 4, the punch *Z* being removed.

The machine is designed to finish nails on both sides; but, for clearness, the working parts on one side thereof are removed.

We do not claim to be the first inventors of a machine for finishing nails, therefore confine ourselves to the devices shown and their equivalents.

We claim as new and desire to secure by Letters Patent—

1. The belt *L*, provided with carriers *M N*, and arranged to place nails at the dies, and to stop during the finishing operation, and move forward, as and for the purpose specified.
2. The pointing-die *b'*, formed of two pieces and combined with the adjusting-wedge *f'*, as set forth.
3. The roller-die *e*, formed of three pieces, and combined with the carriage *C'* and roller *e'*, moved on the arc of a circle by the yoke 1, 5, as specified and shown, and with the carrying devices *L M N*.
4. The die *b'*, combined with spring *f g* and punch *Z*, substantially as described and shown.
5. The combination of the yokes 1, 5 and 3, cams 6 and 8, carriage *C'*, lever *K*, pawl *a* with feed-wheel *B*, as described.
6. The nail-holder *X a'*, constructed as set forth, and combined with the carriage *C'*, rock-shaft *h*, spring *W*, cam *U*, plate *V*, substantially as described.

DANIEL ARMSTRONG.  
JOHN A. HUTCHINSON.

Witnesses:

G. L. CHAPIN,  
HENRY POPE.