

D. GRAVES & C. O. HOWES.

Saw-Guard.

No. 162,814.

Patented May 4, 1875.

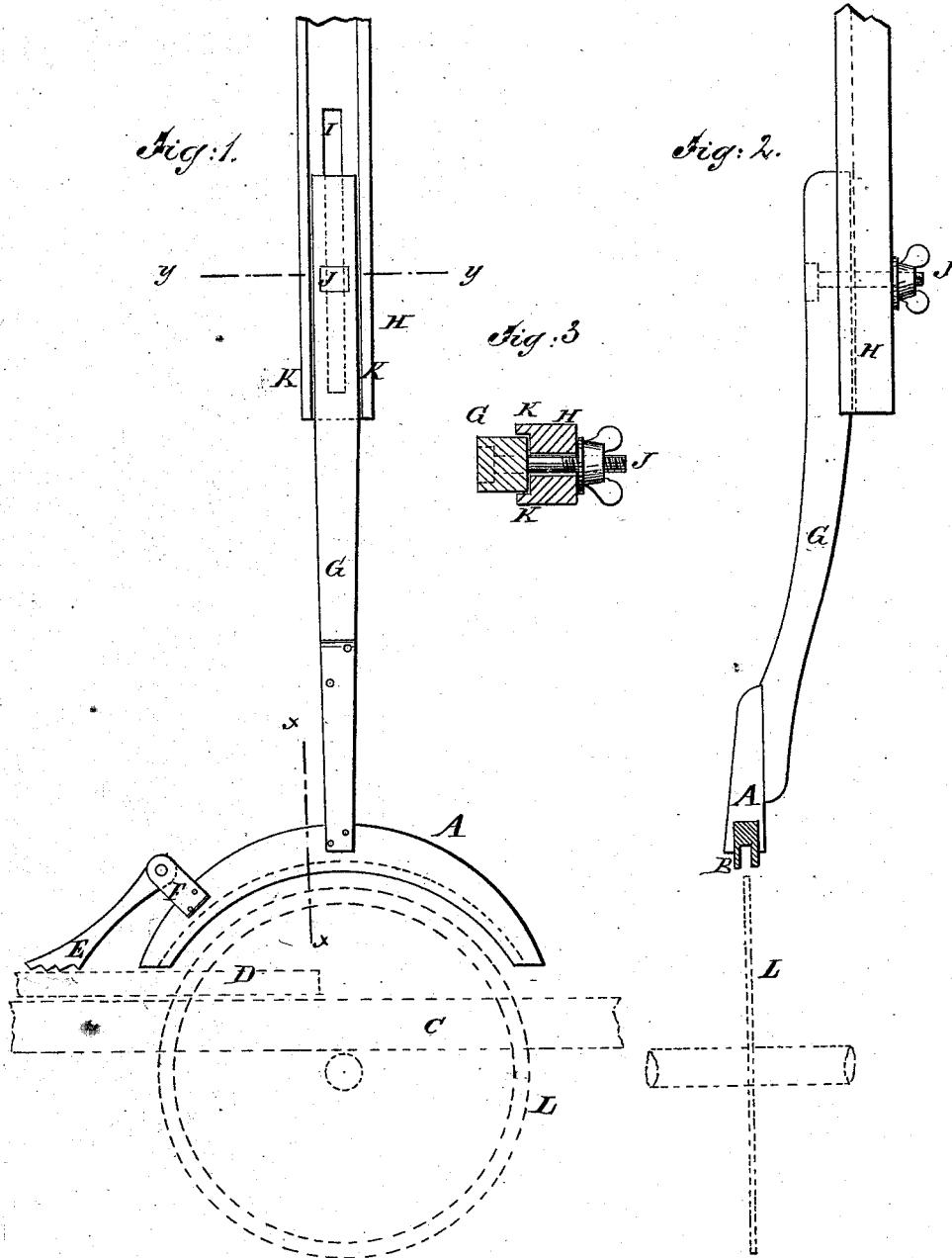

WITNESSES:

Chas. Nida
A. J. Terry

INVENTOR:

D. Graves and
BY *C. O. Howes*
Munn
ATTORNEYS

UNITED STATES PATENT OFFICE.

DWIGHT GRAVES AND CHARLES O. HOWES, OF NORTH AMHERST, MASS.

IMPROVEMENT IN SAW-GUARDS.

Specification forming part of Letters Patent No. **162,814**, dated May 4, 1875; application filed January 18, 1875.

To all whom it may concern:

Be it known that we, DWIGHT GRAVES and CHARLES O. HOWES, of North Amherst, in the county of Hampshire and State of Massachusetts, have invented a new and useful Improvement in Saw-Guards, of which the following is a specification:

The invention will first be fully described, and then pointed out in the claim.

In the accompanying drawing, Figure 1 is a side view of the guard and foot, showing the arrangement over the saw and table. Fig. 2 is a front view, showing a cross-section of the guard on the line *xx* of Fig. 1. Fig. 3 is a cross-section of Fig. 1, taken on the line *yy*.

Similar letters of reference indicate corresponding parts.

A is the guard, which is preferably made of metal, but may be made of wood or other material, with its under side made circular to correspond with the diameter of the saw. In the inner circular edge of the guard is a groove, B. This groove may be of any size, and it may receive the saw, if desired; but ordinarily we prefer to place the guard above the saw, as seen in the drawing. This groove receives the sawdust and prevents its flying. The centrifugal force and motion of the saw carries the dust through the groove and down through the table. C represents the table. D is the piece being sawed. E is the foot, which is hinged to the stationary stand F on the guard.

The lower end of this foot is serrated and rests upon the piece D, as seen in the drawing for preventing the rising of the piece, and to hold it firmly in position. When this foot is not required it can be thrown back onto the guard out of the way. Attached to the guard in any manner is the piece G. This piece may be crooked or curved, as seen in Fig. 2, or made in any other suitable form. H is a slotted and grooved piece, which is attached to the upper floor-timbers, and is of course stationary. The hanging piece G is made adjustable in the piece H by means of the slot I and the bolt J, and is guided or kept in position by the flanges K K. The pieces G and H may be made of either wood or metal. Any other suitable device may be employed to render the saw-guard adjustable as to height, according to the diameter of the saw or height of the room. L is the saw.

Having thus described our invention, what we claim as new, and desire to secure by Letters Patent, is—

The combination of slotted flange-piece H, hanger G, guard A, stand F, and jointed foot E, all constructed and arranged to operate in the manner described.

DWIGHT GRAVES.
CHARLES O. HOWES.

Witnesses:

LUCIUS INGRAM,
LEANDER M. DICKINSON.