

G. MANVEL.
Roofing-Tiles.

No. 162,836.

Patented May 4, 1875.

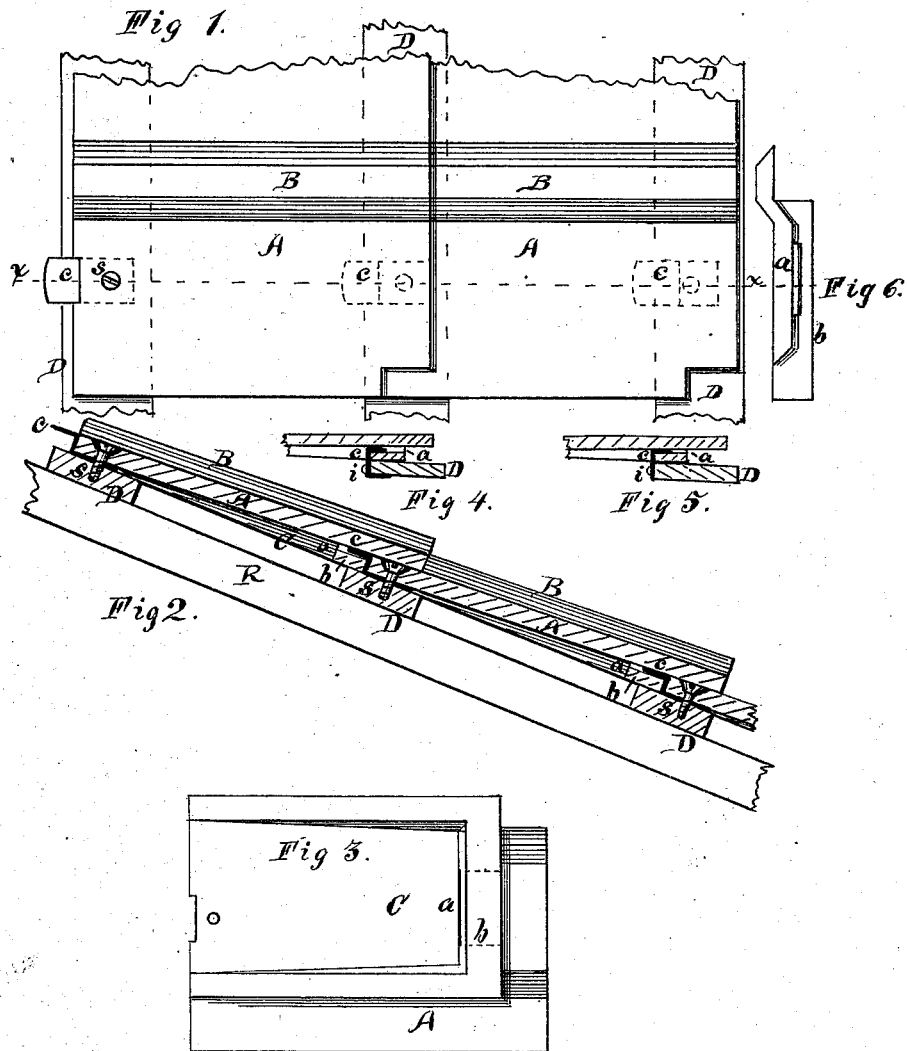

Witnesses:
Jas F Gordon
E. C. Eves.

Inventor:
G. Manvel
By Wood, Loughborough
Atty

UNITED STATES PATENT OFFICE.

GARRY MANVEL, OF ROCHESTER, NEW YORK.

IMPROVEMENT IN ROOFING-TILES.

Specification forming part of Letters Patent No. **162,836**, dated May 4, 1875; application filed October 20, 1874.

To all whom it may concern:

Be it known that I, GARRY MANVEL, of Rochester, in the county of Monroe and State of New York, have invented certain new and useful Improvements in Roofing-Tiles; and I do hereby declare that the following is a full, clear, and exact description thereof, reference being had to the accompanying drawings making part of this specification, in which—

Figure 1 is a top or plan view of two whole tiles and a portion of two others, made on my improved plan, and representing them as applied to the roof. Fig. 2 is a section on the line *x* in Fig. 1. Fig. 3 is an inverted view of a single tile. Figs. 4 and 5 represent modifications of the method of attaching the tiles to the roof. Fig. 6 is an end view of the lower end of a tile.

This invention constitutes an improvement upon that set forth in my patent of February 3, 1874, No. 147,061; and it consists in so shaping the tiles as to afford them a flat bearing upon the roofing-bars and upon each other, and at the same time give a uniformity of thickness from end to end; also, in an improved method of attaching them to the roof.

I make the tiles substantially as heretofore made, except that I form them with a sort of wedge-shaped cavity or depression, C, Figs. 2 and 3, in the under face, and a thin mortise, *a*, next to the body of the tile through the rib *b*. It was found in practice that the tiles, as formerly shaped, were very liable to crack in burning, &c., owing to their unequal thickness. This difficulty I entirely obviate by shaping them as herein shown. The mortise

a is provided to receive the lip *c* of the metal clip, which is secured to the roofing-bars D by the screws *s*, which latter also pass through the upper end of the tiles and hold them. The hole in the tiles to receive the screws is countersunk, and made somewhat larger than the screw, and is filled with cement, into which the head of the screw is embedded. The clip *c* is preferably made as shown in Figs. 1 and 2, and the tiles of each successive course are placed in position and slipped down, so that the shoulder formed by the rib *b* rests against the upper end of the one in the same tier in the course below. The clip *c* enters the mortise *a*, and thus securely locks that end of the tile, and the lap covers the screw that holds it. The upper end is secured by a screw, which also holds the clip that locks the butt of the next tile above. The clip *c* might be made U-shaped, as shown in Fig. 4, or L-shaped, as shown in Fig. 5, if desired, and in either case they may be nailed to the timber D, as shown at *z*, Figs. 4 and 5.

What I claim as my invention is—

1. The roofing-tile, provided with the wedge-shaped depression C, substantially as and for the purposes shown and described.
2. The roofing-tile, formed substantially as shown and described, and provided with the mortise *a*, for the purpose set forth.
3. In combination with the roofing-tile A, the locking-clip *c*, for the purpose set forth.

GARRY MANVEL.

Witnesses:

WM. S. LOUGHBOROUGH,
P. B. HULETT.