

A. MARLAND & W. J. LEWIS.
 Machine for Making Plow-Caps.

No. 162,839.

Patented May 4, 1875.

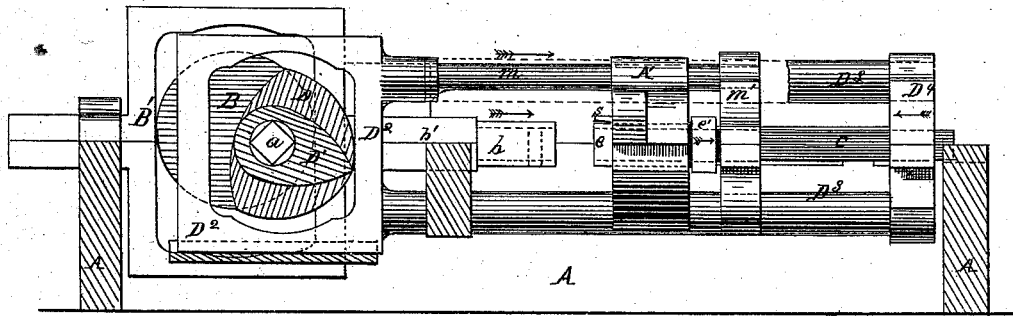

Fig. 1

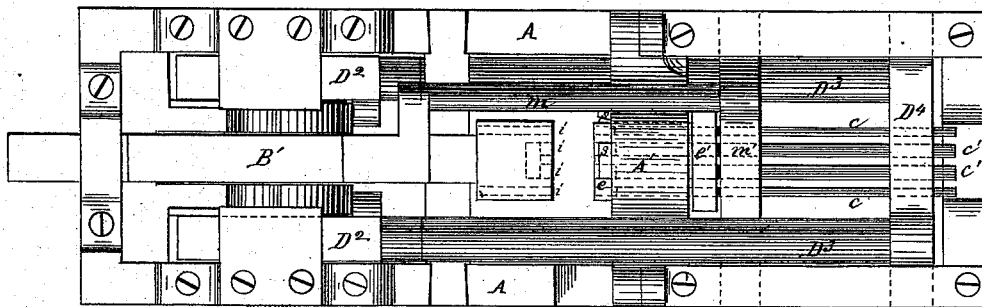

Fig. 2

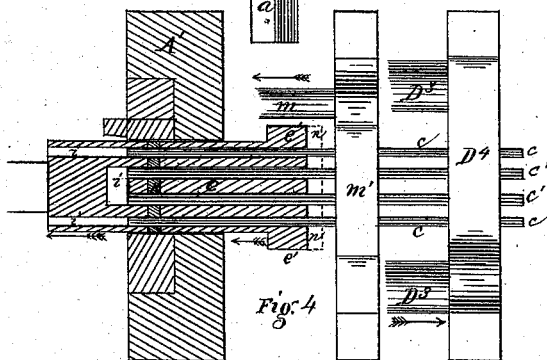

Fig. 3

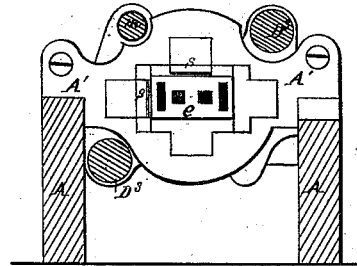

Fig. 4

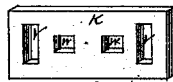

Fig. 5

Witnesses / Francis L. Clark
 Wladimir S. Parker

Inventors Alfred Marland,
 William Lewis,
 by Geo. H. Christy, Atty

UNITED STATES PATENT OFFICE.

ALFRED MARLAND AND WILLIAM J. LEWIS, OF PITTSBURG, PENNSYLVANIA.

IMPROVEMENT IN MACHINES FOR MAKING PLOW-CAPS.

Specification forming part of Letters Patent No. 162,839, dated May 4, 1875; application filed April 2, 1875.

To all whom it may concern:

Be it known that we, ALFRED MARLAND and WILLIAM J. LEWIS, of Pittsburg, county of Allegheny, State of Pennsylvania, have invented or discovered a new and useful Improvement in Machine for making Plow-Caps; and we do hereby declare the following to be a full, clear, concise, and exact description thereof, reference being had to the accompanying drawing, making a part of this specification, in which—like letters indicating like parts—

Figure 1 is a sectional elevation of our machine just inside the front part of the frame; Fig. 2 is a top or plan view thereof; Fig. 3 is a transverse section across in front of the die-box; Fig. 4 is a horizontal section through the dies and die-box, and showing a top view of the punches, stripper, and punch cross-head; and Fig. 5 is a perspective view of the article produced.

Our improvement is particularly designed for the manufacture of plow-caps, so known in the trade, which consist commonly of wrought-iron plates about six inches long, two and a half or three inches wide, more or less, and have holes cut or punched therein, as illustrated in Fig. 5.

By our machine we cut the blanks for these plates from the bar, carry them into a close die-box, punch them, and discharge them complete from the machine at the one operation.

In the drawings, A represents the main frame of the machine, having any suitable construction. The cross-head, in which is the die-box, is shown at A'. The main shaft a has affixed to it a series of cams or eccentrics of suitable form for giving the motions desired, one of which, B, operates in a yoke, B', so as to operate the cutting-die and stripper. On each side of the eccentric are two cams, D D', (a single pair being shown in Fig. 1,) which coact in operating the punches. These cams operate in the cam-yokes D², which latter are connected, by draw-bars D³, to the sliding cross-head D⁴, and in this cross-head are secured the vertical side punches c c for punching the end holes v v in the cap k, Fig. 5, and the middle punches c' c' for punching the middle holes w w. The yoke B' has two connections, one, by a stem, b', to the cutting-

die b, for cutting off the blanks, carrying them into the die-box, and holding them while being punched; and the other is, by a draw-bar, m, to a sliding cross-head, m', which, on the reverse-stroke of the die b and punches c c', operates as a stripper, to remove the punched cap and discharge it from the machine. In the fixed cross-head A' is the die-box, of a length and height in cross-section equal to the length and width of the plow-cap to be made. The feeding side being from the right in Fig. 3, the usual feeding-stops s s are attached. The rear die e is inserted in the cavity in the usual way, but so that its rear end e' (Figs. 1, 2, and 4) may be engaged by the stripper m' at the proper time. The punches c c' pass through this rear die, the holes for such purpose being shown in Figs. 3 and 4. The cutting-die b, which in operation constitutes the front die of the die-box, (Fig. 4,) has the usual cavities i i for the entrance of the forward ends of the punches, and the discharge of the punchings.

In operation, the devices all being in the position they occupy at the end of their reverse stroke, the heated bar is fed in, the die b advances, cuts off the blank, forces it into the die-box, forcing back the rear die e at the same time. The cross-head D⁴ then advances, and, carrying the punches c c', forces the latter through the blank, the die b being at the same time held up to its work so as, whether standing or moving in either direction, to hold the blank up against the punches. The punchings pass out at i i. The reverse action of the machine then commences. The stripper m' comes forward against the base e' of the die e at the same time that the die b moves back and the cross-head D⁴, and punches c c' begin their back stroke, whereby the plow-cap k is stripped off the punches, and, by the still continued forward movement of the die e, is delivered from the machine complete, and, after the removal of the fin, if any, by the usual means, ready for sale or use.

When, as is sometimes the case, a single long slot is desired in the plow-cap instead of the two middle holes shown, a single punch of suitable form may take the place of the two middle punches c' c'. And to adapt the machine for the making of plow-caps of dif-

ferent thicknesses, a short length of motion is allowed to the stripper *m'* before it engages the base *e'* of the die *e*, but such space (shown at *n*, Fig. 4) may be filled up by removable plates, suitably slotted or recessed for the purpose, the position of one such being shown by dotted lines. The side dies *c*, it will be observed, are oblong in cross-section, so as to make slots *v* in the cap longer than they are wide, the longest direction being transverse to or cross-wise of the cap, the object being to facilitate adjustment.

We claim as our invention—

In a machine for making plow-caps, the combination of the die-box, the front and rear dies *b e*, the rectangular side punches *c c*, rectangular middle punches *e'*, and stripper *m'*, constructed, arranged, and operated substantially as set forth.

In testimony whereof we have hereunto set our hands.

ALFRED MARLAND,
WILLIAM J. LEWIS.

Witnesses:

C. E. MILLIKEN,
G. H. CHRISTY.