

**G. H. PHILLIPS.**  
**Reservoir Cooking-Stove.**

No. 162,857.

Patented May 4, 1875.

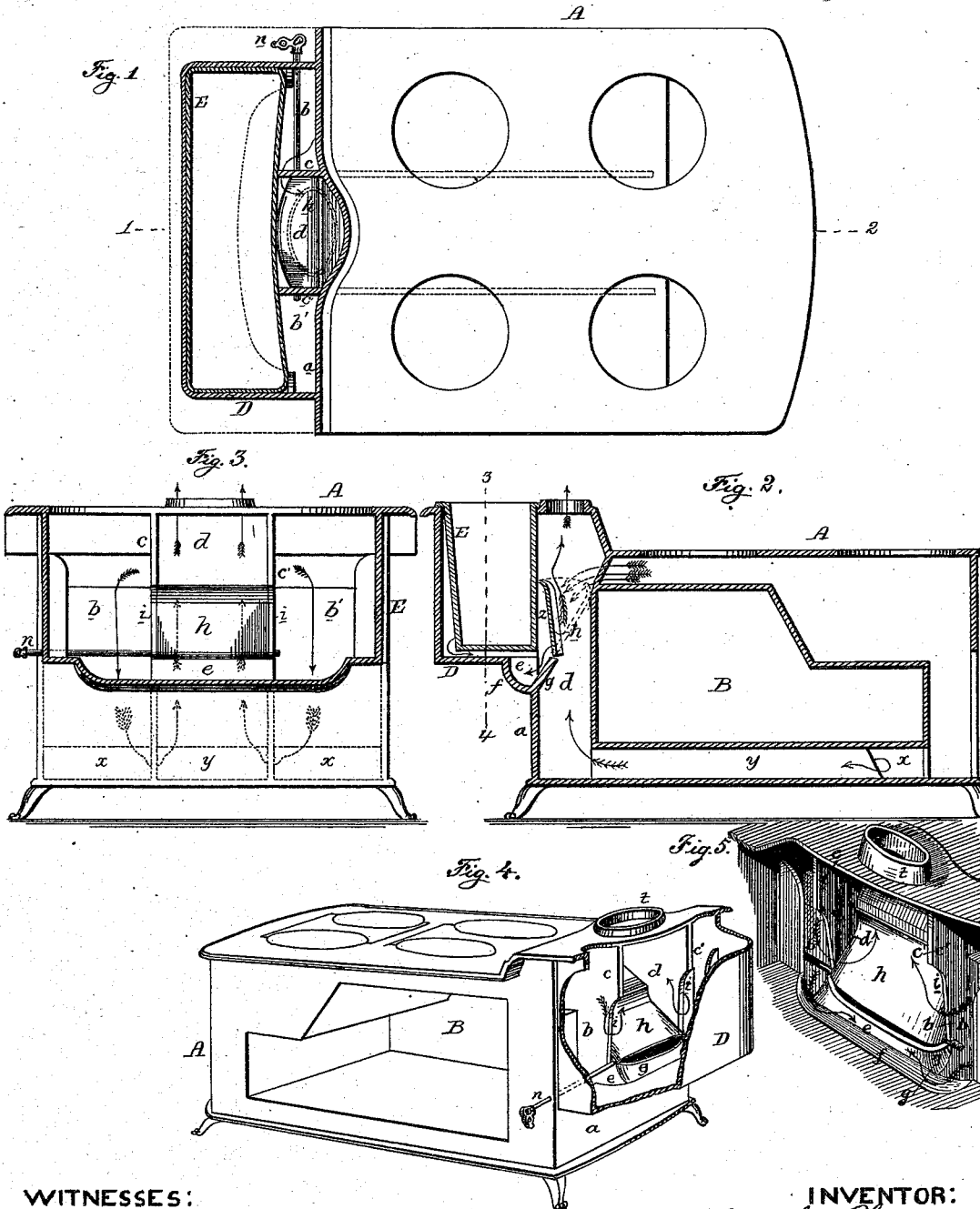

WITNESSES:

*J. L. Skidmore*  
*Edw. W. Dowd*

INVENTOR:

*Geo. H. Phillips*  
*By his Atty.*  
*Howard & Co.*

# UNITED STATES PATENT OFFICE.

GEORGE H. PHILLIPS, OF TROY, NEW YORK.

## IMPROVEMENT IN RESERVOIR COOKING-STOVES.

Specification forming part of Letters Patent No. 162,857, dated May 4, 1875; application filed February 13, 1875.

*To all whom it may concern:*

Be it known that I, GEORGE H. PHILLIPS, of Troy, Rensselaer county, New York, have invented Improvements in Water-Reservoir Stoves, of which the following is a specification:

The object of my invention is a water-reservoir stove, in which the products of combustion from the fire-place, whether caused to circulate around the oven or to pass directly to the chimney, are always brought in contact with the water-reservoir; and this object I accomplish by the use of but one valve or damper, in connection with passages and openings, arranged to control at the same time the currents, which effect the double purpose of heating the oven and the water-reservoir, as described hereafter, and shown in the accompanying drawings, in which—

Figure 1 is a plan view, partly in section, of a cooking-stove with my improvements; Fig. 2, a longitudinal section on the line 1 2, Fig. 1; Fig. 3, a transverse section on the line 3 4, Fig. 2; and Figs. 4 and 5, perspective views, part of the outer casing being removed.

The body A of the stove is, in the present instance, of the usual rectangular form, having an oven, B, a fire-place, C, at the front, and extended at the rear to form a casing, D, with an opening, *w*, at the top, for the reception of a detachable water-reservoir, F. The back *a* of the stove is cut away opposite the casing D, and the space at the rear of the oven is divided by partitions *c c'* into diving-flues *b b'* and a central ascending flue, *d*, the diving-flues communicating with the usual side flues *x x*, and the ascending flue with the central flue *y* beneath the oven. The bottom *f* of the casing D, adjacent to the back plate *a*, is inclined downward, forming a channel or passage, *e*, for a purpose described hereafter; and between the partitions *c c'*, from the point where the inclined bottom *f* joins the back plate, extends a flange, *g*, inclined inward, its upper edge being adjacent to the lower edge of a valve, *h*, fitting closely, but so as to swing freely between the partitions *c c'*, and operated by a rod, *v*, resting in recesses in said partitions, projecting through the side plate of the stove, and provided with a suitable handle at its outer end. The upper

end of the valve *h* is curved, so that when the edge of the valve is in contact with the adjacent side of the reservoir E there will be a space, *z*, between the valve and the reservoir, and each partition *c c'* is cut away to form recesses or passages *i i*, allowing a free communication between the space *z* and the side flues *b b'*. The reservoir E is somewhat less in depth than the casing D, and is contracted toward its lower end, so that there is a space between the casing and the sides, back, and bottom of the reservoir. The front side of the latter, however, is nearly vertical, so as to be in contact with the edges of the partitions *c c'*, the reservoir thus closing and forming the rear sides of the flues *b b'* for a part of their length.

When it is desired that the products of combustion from the fire-place shall circulate round the oven the valve *h* is brought to the position shown in Fig. 2, with its edge in contact with the reservoir. The gases will then pass over the oven, through the diving-flues *b b'* and bottom flues *x x*, and back through the central flue *y* and ascending flue *d* to the exit-opening *t*. In passing through the flues *b b' d* the heated gases are brought into direct contact with the inner side of the reservoir, the contents of which are thereby heated.

When a direct draft is required the valve *h* is turned to the position shown in Figs. 1, 4, and 5, and in dotted lines, Fig. 2, when the gases will descend the diving-flues to the recesses *i i* in the partitions *c c'*. Through recesses they will pass into the ascending flue *d*, and up the latter to the exit-pipe; but in this instance, as before, there is a direct contact of the gases with the whole inner side of the reservoir, which therefore is as thoroughly heated by the direct as by the circulating draft around the oven, while the change from one to the other is effected through a single adjustment of an ordinary valve or damper.

It will be seen that, whatever may be the position of the valve, there is a free circulation of the gases between the reservoir and its casing D, through the space *z* and the channel *e*, which circulation, in addition to the direct contact of the gases in passing through the flues, still further heats the reservoir and its contents. When it is desired to replace or repair

the valve or damper, easy access may be had thereto by simply removing the water-reservoir E.

I do not desire to confine myself to the precise construction and arrangement of parts described, as alterations may be necessary or desirable in adapting the invention to stoves or ranges of different forms—such, for instance, as dispensing with one of the diving-flues, or altering the form and position of the valve.

I claim as my invention—

1. The combination of the body A and casing D of a stove, the partitions *c c'*, having recesses *i*, the valve *h*, covering said recesses, and water-reservoir E, smaller than the interior of the casing, whereby a gas-circulating space is formed completely round and beneath the reservoir, substantially as and for the purpose set forth.

2. The combination, in a reservoir-stove, of a reservoir, E, partitions separating the diving and rising flues, and having recesses *i*, through which said flues may communicate,

and a valve or damper arranged in one of the flues, and closing the same when adjusted to one position, and covering the recesses *i* when adjusted to another position, all substantially as set forth.

3. The combination of the reservoir E, diving and rising flues, communicating passages *i i*, and valve *h*, arranged to bear with its upper edge against the reservoir and form a circulating passage, *z*, as set forth.

4. The combination of the reservoir-flues *b d*, valve *h*, and channel *e*, forming a communication in the stove, between the outer flues and around the central flue, as and for the purpose set forth.

In testimony whereof I have signed my name to this specification in the presence of two subscribing witnesses.

G. H. PHILLIPS.

Witnesses:

ERASTUS GEER,  
EDWARD P. MANOR.