

M. A. GRIFFITH.
Screw-Cutting Dies.

No. 162,914.

Patented May 4, 1875.

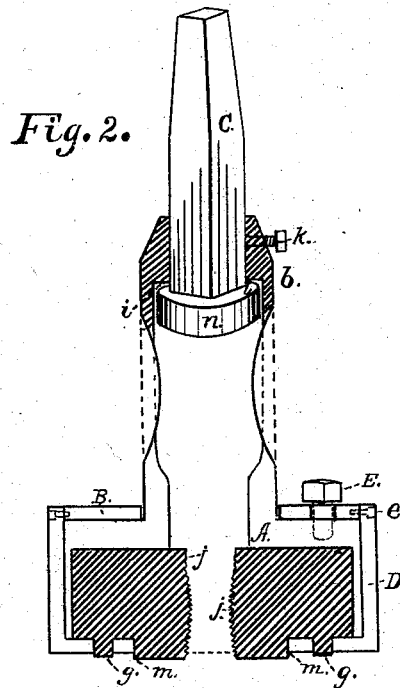
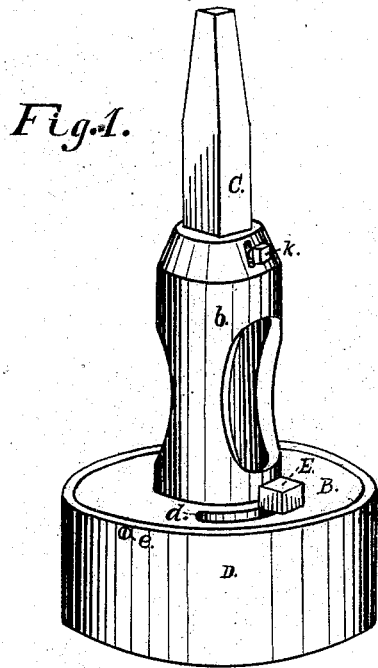

Fig. 3.

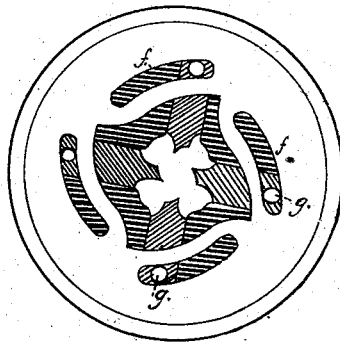
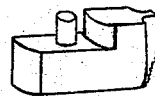

Fig. 4.



Witnesses:

Jacob F. Ebert
J. P. Whitman

Inventor:

M. A. Griffith
by his Atty.
Chas. M. Peck

UNITED STATES PATENT OFFICE.

MORTIMER A. GRIFFITH, OF DAYTON, OHIO.

IMPROVEMENT IN SCREW-CUTTING DIES.

Specification forming part of Letters Patent No. **162,914**, dated May 4, 1875; application filed January 20, 1875.

To all whom it may concern:

Be it known that I, MORTIMER A. GRIFFITH, of Dayton, State of Ohio, have invented a new and useful Improvement in Screw-Cutting Dies; and I do hereby declare that the following is a full and exact description of the same, reference being had to the accompanying drawings, and to the letters of reference marked thereon.

My invention relates to that class of dies for screw-cutting designed as a tool for use in a brace, and provided with radially-moving chasers or cutting-jaws; and it consists in the novel combination and arrangement of its parts, by which, in cutting a thread upon a projecting bolt, the whole part thus projecting can be cut close up to the surface against which the nut is to be screwed. By means of a set-screw the jaws may be adjusted and rigidly held in the position desired.

Figure 1 is a perspective view of my improved die. Fig. 2 represents a central section of the same in elevation. Fig. 3 is a face view of the die. Fig. 4 is a representation of one of the chasers.

In work upon carriages it not unfrequently occurs that several of the bolts, by use, become much worn and require rethreading. To accomplish this in the ordinary way it would be necessary, in many cases, to remove the bolt at the cost of much labor and trouble. My invention has in especial view such cases, and the object of it is the production of a tool, to be used in a brace, that shall be light, conveniently arranged, and thoroughly efficient.

In the accompanying drawings, A represents the body of the die, slotted or recessed radially upon its face to admit the chasers, and terminating in a hollow shaft, *b*, provided at its end with an adjustable tapering shank, C, by which it can be secured in a brace. An annular disk, B, of the same diameter as the body of the die, with a segmental slot, *d*, fits snugly but not tight around the shaft *b*, against the body of the die A. To this disk is securely fastened, by the screws *e*, the face cap or shell D. Fig. 3 shows the form of the face of the cap, and it will be noticed that the aperture in which the shoulders of the cut-

ting jaws or chasers are confined is of an eccentric or cam shape. Eccentric grooves or slots *f* run parallel to the edges of this aperture, and in them the studs *g*, projecting from the chasers, work. The square shank C, Fig. 2, fits snugly in the end of the shaft *b*, and terminates at its bottom in a circular lug, *n*, which, by means of the shoulders *i*, prevents the shank from being withdrawn. A set-screw, *k*, holds it at any desired position, while the strain consequent upon use of the die is borne by the faces of the square aperture in which the shank is confined. The object of this adjustable shank, which may be graduated, is to cut an equal number of threads upon several bolts in succession, without the trouble of measuring each and watching the cutters. The cutters, Fig. 4, are of the ordinary shape, but project beyond the face of the die, as seen in Fig. 2. This arrangement of the chasers is an important feature of my invention, as it enables a thread to be cut close to the surface against which the nut is to be screwed. The eccentric slots *f* actuate the chasers by means of the studs *g*, and the projecting shoulders *m* aid in holding the jaws at any required position. It is very essential, in the use of the die, that the cutting-jaws should be firmly retained without liability of slipping from the proper adjustment. The set-screw E, by the pressure of its head against the annular disk B, accomplishes this.

I claim and desire to secure by Letters Patent—

The improved screw-cutting device, constructed substantially as described, and consisting of the shank C, circular shaft *b*, boss A, threading-jaws *j*, and surface shell D, provided on its face, from which the chasers project, with an eccentric aperture and slots *f*, as and for the purpose specified.

Witness my hand this 14th day of January, 1875.

M. A. GRIFFITH.

Witnesses:

CHAS. M. PECK,
JACOB F. EBERT.