

B. ILLINGWORTH.
Harvester.

No. 162,927.

Patented May 4, 1875.

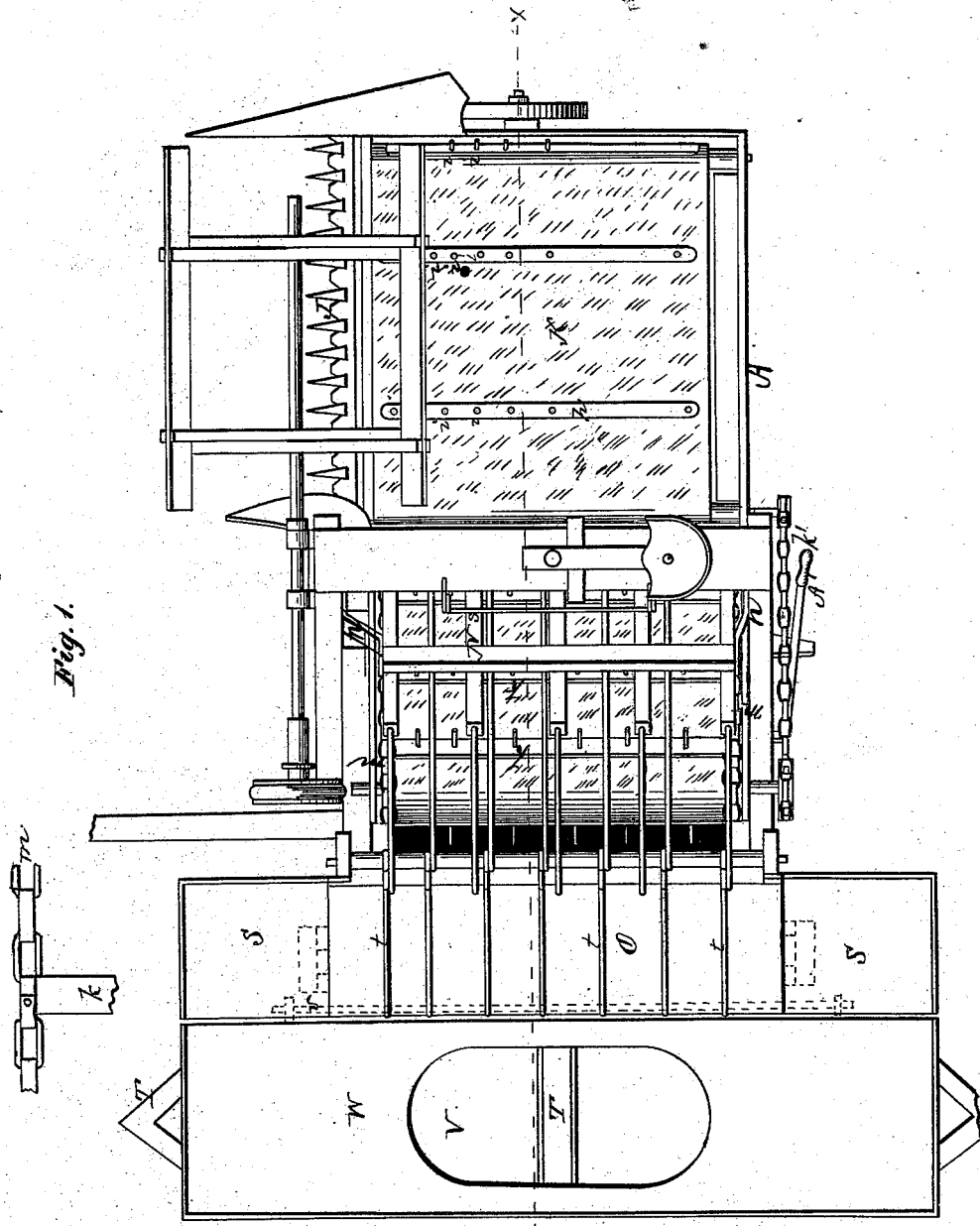

Fig. 1.

WITNESSES

Henry M. Miller
C. L. Ewert.

INVENTOR

Berj. Illingworth,
per
Kander & Mason
Attorneys

B. ILLINGWORTH.
Harvester.

No. 162,927.

Patented May 4, 1875.

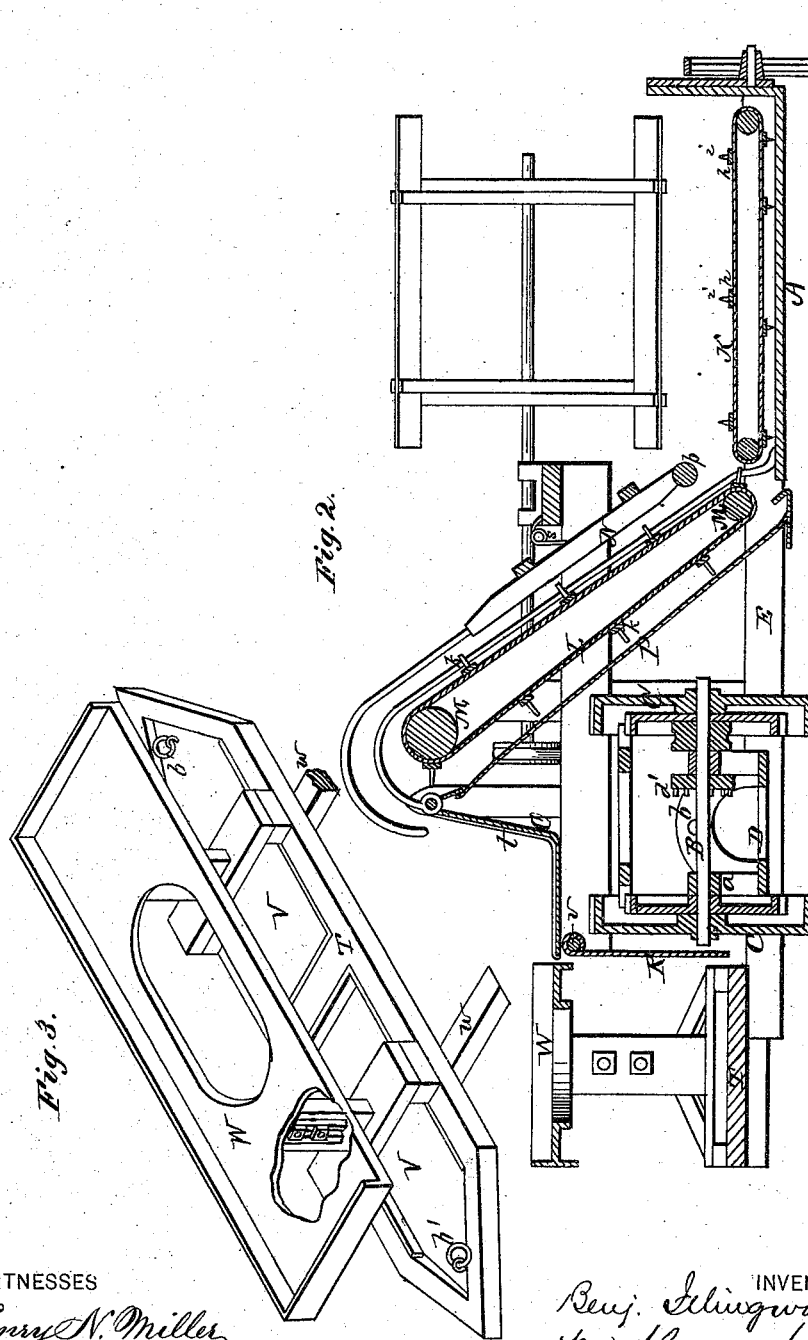

WITNESSES
Henry N. Miller
C. L. Ewert.

INVENTOR
Benj. Illingworth,
per *Alfred Mason*
ATTORNEYS

B. ILLINGWORTH.
Harvester.

No. 162,927.

Patented May 4, 1875.

Fig. 5.

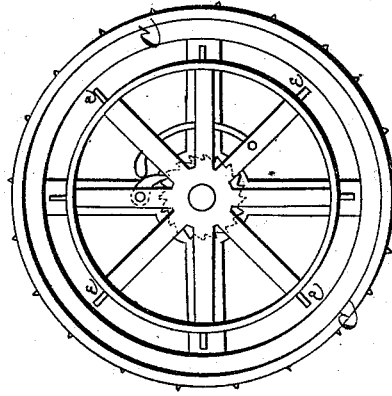
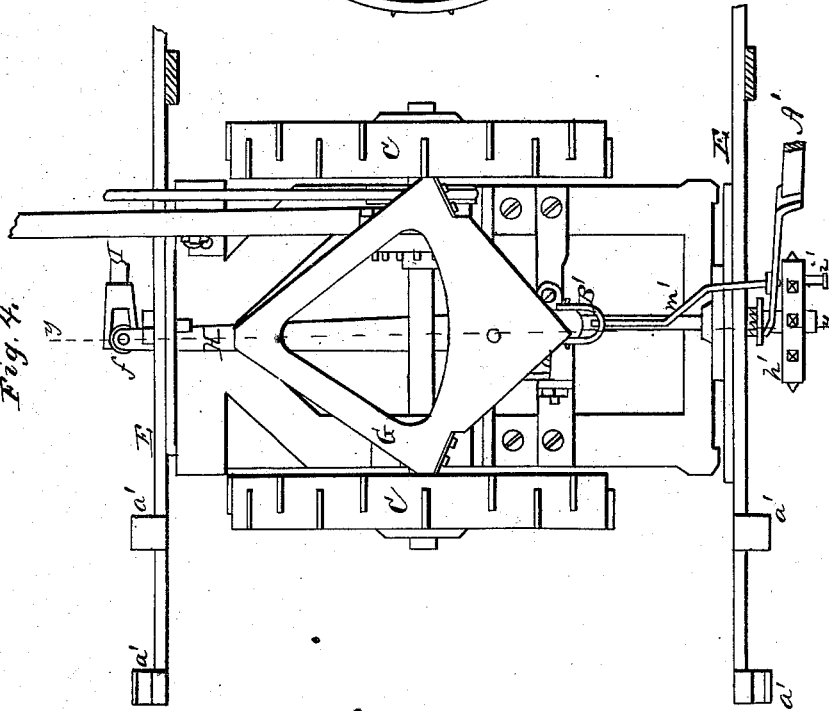

Fig. 4.



WITNESSES

Henry N. Miller
C. L. Ewert.

INVENTOR

Benj. Illingworth.
per Amanda Mason
ATTORNEYS

B. ILLINGWORTH.
Harvester.

No. 162,927.

Patented May 4, 1875.

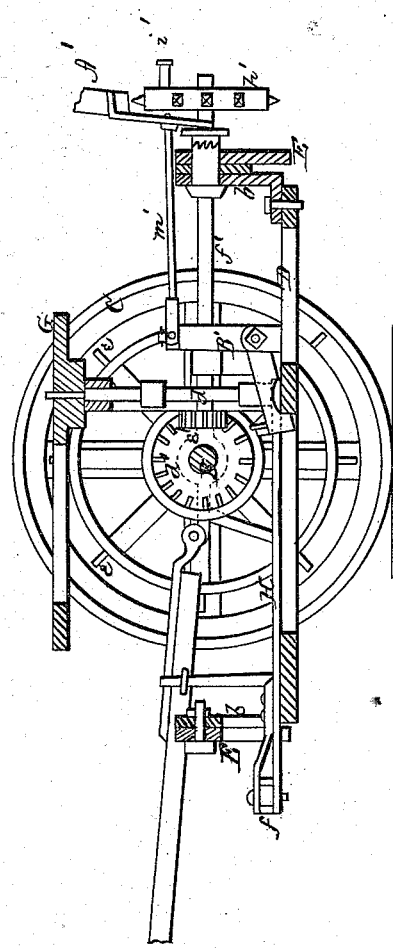

Fig. 6.

WITNESSES

Henry N. Miller
C. L. Ewert

INVENTOR

Benj. Illingworth
per *Hauden Mason*
ATTORNEYS

UNITED STATES PATENT OFFICE.

BENJAMIN ILLINGWORTH, OF HAMPTON, IOWA, ASSIGNOR OF TWO-THIRDS HIS RIGHT TO R. S. BENSON AND A. M. MOTT, OF SAME PLACE.

IMPROVEMENT IN HARVESTERS.

Specification forming part of Letters Patent No. **162,927**, dated May 4, 1875; application filed January 25, 1875.

To all whom it may concern:

Be it known that I, BENJAMIN ILLINGWORTH, of Hampton, in the county of Franklin and in the State of Iowa, have invented certain new and useful Improvements in Harvesters; and do hereby declare that the following is a full, clear, and exact description thereof, reference being had to the accompanying drawings, and to the letters of reference marked thereon, making a part of this specification.

The nature of my invention consists in the construction and arrangement of a harvester, as will be hereinafter more fully set forth.

In order to enable others skilled in the art to which my invention appertains to make and use the same, I will now proceed to describe its construction and operation, referring to the annexed drawings, in which—

Figure 1 is a plan view of my entire harvester. Fig. 2 is a longitudinal vertical section of the same. Fig. 3 is a perspective view of the binder's platform and table. Fig. 4 is a plan view of the operating mechanism with the receiver removed. Fig. 5 is a side view of one of the driving-wheels. Fig. 6 is a vertical section through the line *y y*, Fig. 4.

A represents the frame-work of the harvester constructed in any suitable manner to contain the various working parts. B is the axle upon the ends of which the driving-wheels C C are placed, said wheels being connected with the axle by means of the usual pawl and ratchet, as shown in Fig. 5, so that the axle will be revolved only while either or both wheels are turning forward. The axle B has its bearings in posts or boxes *a a*, projecting upward from a skeleton platform, D, which has at each end a flange, *b*, and these flanges are pivoted to front and rear arms E E, extending from the main frame, the pivots being on a line at right angles with and above the center of the axle. By this means either wheel may be raised or lowered without materially affecting the binding apparatus, the cutter-bar, platform, or elevator, allowing either wheel to pass over an obstruction or drop into a hole without materially disturbing the other parts of the machine. On the platform D is a suitable frame in which the vertical

shaft *d* has its bearings, and on the upper end of said shaft is secured the diamond-shaped plate G, which is rocked from side to side by means of lugs *e e* projecting radially from rings attached to the inner sides of the driving-wheels, in the manner described in a patent granted to me November 15, 1870. Near the lower end of the shaft *d* is secured an arm, H, which extends forward beyond the front arm E, and its front end is, by a universal joint, *f*, connected with a rod, I, said rod extending to and connected to the cutter-bar J, thus operating the same. The grain cut by said cutter-bar falls onto an endless revolving apron, K, or canvas platform, upon which are secured cross-bars *h* provided with projecting pins *i* to assist in carrying forward the butt ends of the cut grain, thus presenting it to the elevator regularly and evenly. The pins *i i* are only at the front ends of the cross-bars *h*, where the butt ends of the grain falls, while the upper ends of the grain, falling along the rear portion of the platform-apron are carried forward without such pins. The grain is then carried upward by the elevator composed of an endless apron, L, passing around rollers M M, and provided with toothed cross-bars *k k*, or bars provided with pins or teeth. These bars extend beyond the apron, and are riveted to chains *m m*, on both sides. I thus employ two endless chains to operate the elevator, and the cross-bars being fastened to said chains, any wet or tangled grain will not clog its operations, and nothing can stop it but by breaking one or both of the chains. The grain is pressed to the elevator by means of a grating, N, which is connected to the main frame by means of pivoted arms *n n*. At the bottom of the grating N is a roller, *p*, which assists in delivering the grain to the elevator, and a single spring, *s*, holds it in its position, and presses the grain to the elevator. The elevator discharges the grain upon a receiver, O, made nearly L-shaped, and hinged along its upper edge. This platform is provided with wires *t*, making the grain more easily gathered up by the binders, and with less injury to their hands. By means of these wires, also, the platform may be easily raised for the purpose of oiling or inspecting the machinery,

and when the platform is lowered it is kept closely in its place by means of a spring, P. The spring P is simply the lining of the elevator, and must be pressed downward at its top by the hands when the platform is to be lowered, so that it will act as a spring. By means of a bolt, *v*, under the receiver O, an apron, R, is held in place to protect the feet of the binders from the wheel. The ends of the bolt *v* extend beyond the ends of the receiver O, and support auxiliary receivers S S, one at each end, and, by removing the bolt, these auxiliary receivers may be lowered like table-leaves, thus requiring less room for storing the machine. T represents the standing-platform for the binders, which is attached by means of arms *w* in loops *a'* on the arms E E, these latter arms extending across the machine, and the platform is attached in such a manner that when either one of the wheels C drops into a hole, the platform will lower but half the distance the wheel has lowered, thus saving much of the jolting of other machines, so liable to break the machine and so unpleasant to the binders. The standing-platform T is skiff-shaped with the ends elevated to pass more readily over obstructions, and the bottom of the platform is formed of two pans, V V, constructed so as to hold the shattered grain, either of which may be taken out at pleasure to discharge the loose grain collected therein by the use of rings *b'* attached at either end of the platform, thus saving the trouble and inconvenience of scooping the loose grain from the platform. W represents the binding-platform adjustably connected to standards on the standing-platform T, so that it can be raised or lowered at pleasure, to suit the height of the binder, and both binding and standing platforms may be easily and simply taken entirely from the machine, and readily adjusted again. On the axle B is a cog-wheel, *d'*, which gears with a pinion, *e'*, on the front end of a shaft, *f'*, which extends to the rear through the rear flange *b* of the skeleton platform D, and through the rear arm E, forming the rear pivot for the same. On the rear end of the shaft *f'* is placed a toothed

wheel, *h'*, for giving motion to the endless-elevator apron and platform-apron K, by means of the chain *k'*. On the wheel or pulley *h'* is a crank-pin, *i'*, for the attachment of a pitman, if desired. The pulley *h'* is loose, and thrown in and out of gear by means of a lever, A'. Said lever being, by a rod, *m'*, connected with a pivoted elbow-lever, B', the other end of which is bent and split to straddle the arm H, so that by the movement of the lever A' said arm, shaft *d*, and diamond plate G will be raised or lowered to throw the plate in and out of gear with the lugs *e*.

It will thus be seen that the harvester is attached in a simple manner to the running-gears of the machine in the center between the wheels, making it adjustable to the running-gears of a "Buckeye Reaper or Mower," or any other two-wheeled machine.

The machine may be used with the pitman attached to either the front or rear of the machine, as desired.

Having thus fully described my invention, what I claim as new, and desire to secure by Letters Patent, is—

1. The skiff-shaped standing-platform T, having its bottom formed of the two removable pans V V, for the purposes herein set forth.

2. In combination with the standing-platform T, the vertically-adjustable binding-platform W supported thereon, for the purposes herein set forth.

3. The combination of the hinged grain-receiver O, apron R, rod *v*, and hinged end tables S S, all substantially as and for the purposes herein set forth.

4. In combination with the hinged receiver O, the elevator-lining P, forming a spring to hold said receiver in place, substantially as herein set forth.

In testimony that I claim the foregoing I have hereunto set my hand this 23d day of October, 1874.

BENJAMIN ILLINGWORTH.

Witnesses:

C. L. EVERT,
W. A. SKINKLE.