

A. MCKENNEY. Stump-Extractor.

No. 162,936.

Patented May 4, 1875.

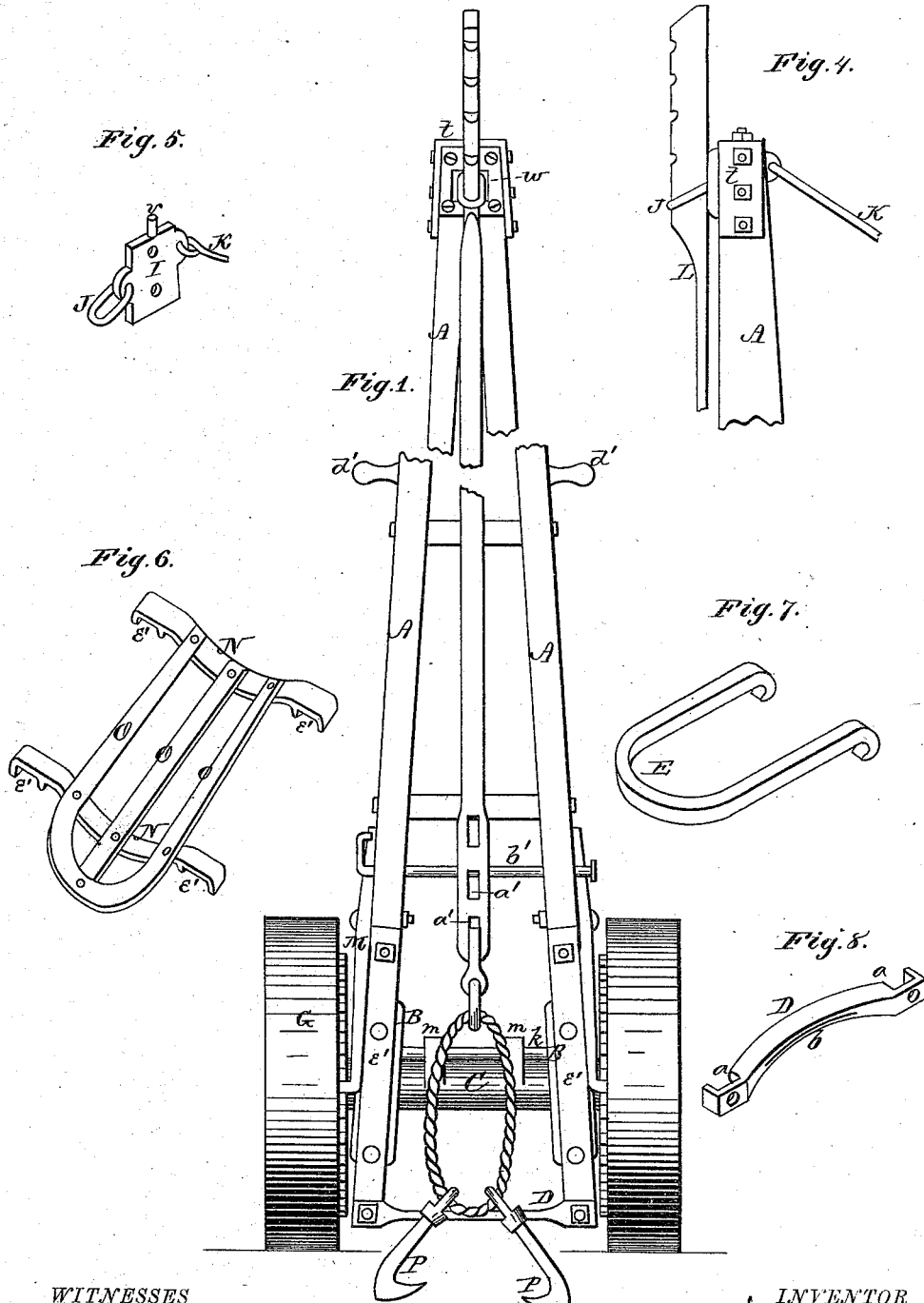

WITNESSES
Henry N. Miller
C. L. Everts By

INVENTOR
Alexander McKenney
Alexander McKenney
 Attorney

A. MCKENNEY.
Stump-Extractor.

No. 162,936.

Patented May 4, 1875.

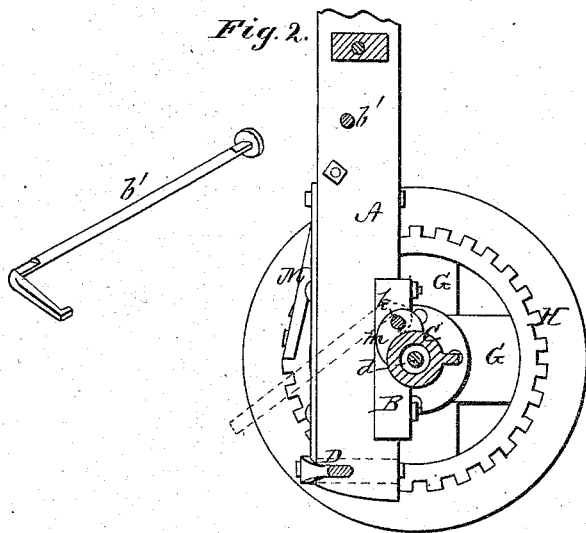

Fig. 9.

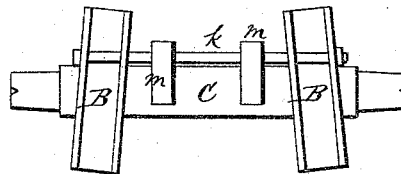
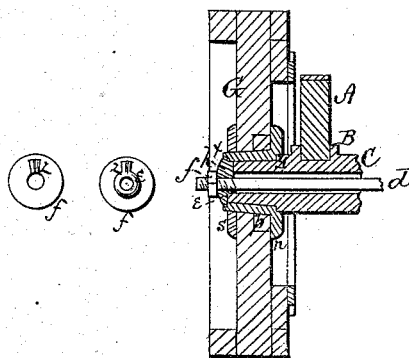

Fig. 3.



WITNESSES

Henry N. Miller By
C. L. Ewert

INVENTOR

Almeron McKenney
Alexander Mason

Attorney

UNITED STATES PATENT OFFICE.

ALMERON MCKENNEY, OF BERLIN, WISCONSIN.

IMPROVEMENT IN STUMP-EXTRACTORS.

Specification forming part of Letters Patent No. 162,936, dated May 4, 1875; application filed March 25, 1875.

CASE A.

To all whom it may concern:

Be it known that I, ALMERON MCKENNEY, of Berlin, in the county of Green Lake and in the State of Wisconsin, have invented certain new and useful Improvements in Stump-Extractors; and do hereby declare that the following is a full, clear, and exact description thereof, reference being had to the accompanying drawings and to the letters of reference marked thereon, making a part of this specification.

The nature of my invention consists in the construction and arrangement of a stump and grub puller and rock-lifter, as will be hereinafter more fully set forth.

In order to enable others skilled in the art to which my invention appertains to make and use the same, I will now proceed to describe its construction and operation, referring to the annexed drawings, in which—

Figure 1 is a rear elevation of my machine. Fig. 2 is a transverse section of the axle, showing the inner side of one of the wheels. Fig. 3 is a longitudinal section through one end of the axle, and the wheel placed thereon. Figs. 4 to 9 are views of detached parts of my machine.

A represents the V-shaped lever-frame made of the best seasoned timber, to resist the breaking strain to be applied to it. This frame rests upon flanges B B of the axle C, and is provided with suitable cross-pieces extending across between the two parts of the lever, with joint bolts for support. A bent cross-bar, D, of iron extends across the lever-frame at the lower end, and is strongly bolted to each side piece of the frame. This bar answers the purpose of a bite to set against the sapling when the pull is made, and it may be permanent or movable, as may be required. It is near the ends provided with shoulders a, which sit against plates on the side pieces to keep them from pressing inward. This bar is bent downward below the edges of the side pieces to admit of the machine being placed nearer the stump or tree, and also to provide a resting-place for the stump while being moved. In some cases I may extend the bar D straight across instead of bending it. In the middle it is provided with a sharp edge, b, to set against the tree. In immediate con-

nection with this lever-frame is the axle C, provided with bottom and side flanges B placed a trifle inclined near the shoulders, forming straight gains across the axle for the two parts of the lever to rest in, and to which they are securely bolted. The axle C is made hollow to secure lightness and strength, and also to admit of an iron bolt or rod, d, passing through it to keep the wheels up to their proper shoulders. The nuts f on the ends of the rod d screw up against caps or large washers h, which set against the ends of the axle. These caps have short tubes e, which extend parallel to the bore and into the hollow axle, the rod d passing through said tubes to hold all in place. The cap h also sits under a light edge or flange, x, of the hub of the wheel, which flange forms a sand band to cover the joint. A similar projection, y, is formed upon the hub on the opposite side of the wheel to cover the joint at the shoulder of the axle, and these projections serve to keep the sand from the journals, which, being thus protected, may be run without lubricating. The washer or cap h is provided with one or more small V-shaped tongues or projections, z, on the inside face, which fits into similarly-shaped notches in the end of the axle, to keep the cap and nut from turning by the revolution of the wheel.

By these simple means it may be seen that the bearings of the wheels may be run very close, and yet turn freely; and by revolving true it enables the brace-hooks to be kept in their proper places for locking the wheels, which is a very essential part of the operation.

Another important part in connection with the axle is an iron rod, k, which runs through the flanges B B and lever-frame A, and through lugs m m on the axle. This rod is used for the clevis E or other hook to hook onto; and it serves also to distribute the strain along the entire length of the axle between the shoulders. This, together with the lever-bearings, being placed near the shoulders enables a long axle to be made without the danger of breaking, which experience has proven to be a serious difficulty with machines heretofore made on a similar plan, where the lever is placed in the middle of the axle, and

the draft of the clevis or other hook being also from the middle of the axle. An axle of sufficient length is a very important consideration, on account of straddling the stump or rock, and also keeping the machine right-side up, and balancing the stump in the middle in a low position, instead of poising it on the top of a single lever, the wheels in such case being too near together to form a base sufficient for a top-heavy load.

The wheels of my machine are each formed of two pieces of plank, G G, crossed in the middle at right angles, and halved together, through the center of which a metallic tube, *p*, passes, said tube having a circumferential flange, *n*, cast on one end, the diameter of the flange being about the same as the square of the crossing of the planks G, where they are halved together. Another flange, S, of the same dimensions is fitted snugly on the other end of the tube *p*. The two parallel faces of these flanges lie flat against the planks G G, and are strongly bolted through the same. The tube and flanges form the joint-protecting flanges *xy*, above described. The wooden parts of the wheel are then completed by filling in between these extended arms a sufficient length to make the width of the fellies, and then any desired thickness of plank is added to each side of these to form the breadth of tread of wheels. Cog-wheels H are then bolted to the inner sides of the wheels.

These wheels may be used either with or without tire, the spaces between the extended arms affording sufficient room to bolt them on transversely through the fellies. The crotch-lever A is strongly ironed at the top, where the two parts are united. An iron plate, I, is set into the timbers between the two parts, and a stirrup, *t*, of band-iron, is passed over the top and down the sides of the lever, and all strongly bolted together. The middle plate I is formed with a strong tenon-bolt, *v*, at its upper edge, which extends upward through the band-iron and is screwed fast by a nut. It has also suitable ears projecting outward beyond the wood of the lever, through the front one of which is passed a long link, K, for the team to draw from, and in the rear one is a heavy gripe-link, J, for the support of the slotted extension-bar L. An iron plate, *w*, is bolted on the rear side of the lever at the top for the support of the under side of the extension-bar, and to keep the gripe-link in a proper position when the extension-bar is pushed upward through it for adjustment to the length required. The upper end of the extension-bar L is made broad and thick enough to fill the inside of the link J, and the under side is flat to sit down upon the irons of the lever, the outside being rounded to fit the link and provided with notches into which the link will drop, gripping the bar tightly and holding it fast when the draft is applied to it. This bar extends downward to near the ground, where it is widened and formed with slots *a'*, to admit hooks connecting it with the grap-

pling-hooks. The frame or lever A has on each side a pivoted brace-hook, M, the lower or hooked ends of which are to drop into the cog-wheels H, on the inner sides of the wheels G, to lock said wheels firmly when the machine is once set for operation. The hooks are raised from the cog-wheels H by means of a rod, *b'*, passed through the frame and flattened or notched on one side, near each end, and at one end provided with a crank or handle. When this rod is turned so that the notches are against the upper ends of the brace-hooks M, their lower ends can fall into the cog-wheels, and lock the driving-wheels when the pull is to be made. To unlock the brace-hooks the rod *b'* is turned so as to bring the rounded portion thereof against the brace-hooks, thereby lifting their lower ends out of the cog-wheels. The lever-frame A is on each side provided with a suitable handle, *d*, for handling the machine, and has also strips *e'* of band iron on the upper edges at the lower end, which strips are fastened by the same bolts that fasten the lever A to the flanges B B. These strips protect the wooden frame and provide a bearing for an iron platform for raising and carrying rock or stone. This platform is constructed of two or more cross-bars, N, of iron, which extend across near the lower ends of the levers, and are bent downward between the same, to form a concave bed, and at the ends of said cross-bars are formed hooks *e'*, with shoulders on both sides of the two parts of the lever. On the cross-bars N are fastened two or more longitudinal iron bars, O O, two of which are formed of one piece bent to form a projecting curved edge at the lower end of the machine. This platform is fastened to the lever after removing the cross-bar D, and is applied to the rock or stone by elevating the lever of the machine a little past a perpendicular position and allowing the curved edge of the platform to sit down against the side of the rock, in a similar manner to a warehouse truck in raising a box or other article.

When the machine is so placed to the rock to be raised, and the rock having been nicked at suitable points for the grappling-hooks P to hold, the rope and hook may be so adjusted as to give the rock something of a rolling lift when the power is applied, and when it has been raised a short distance it may be propped up, the lever pushed back, and the extension-bar raised to take up the slack, and the team may then move forward, bringing the lever down to a horizontal position, and thus raising the rock onto the concave bed. It may then be adjusted by a bar to its proper balance for moving to any desired distances.

The clevis E, above mentioned, is formed of one metal bar bent round in the center, and having two parallel arms with hooks *m'* formed on their ends, to be hooked onto the clevis-rod *k*.

Having thus fully described my invention, what I claim as new, and desire to secure by Letters Patent, is—

1. In a stump and grub puller, the combination of the crocheted lever A and the axle C, having flanges B B formed thereon, all arranged substantially as and for the purposes herein set forth.

2. The clevis bar or rod *k*, arranged in combination with the axle C, having projections *m m* and flanges B B formed thereon, and the crocheted lever A, substantially as for the purposes herein set forth.

3. In a stump-extractor, the wheel G, constructed as described, in combination with the tube *p* and flanges *s n*, having the joint-projecting flanges *x y*, forming the journal-bearings, substantially as and for the purposes set forth.

4. In a stump-extractor, the combination of the hollow axle C, wheel G, rod *d*, nut *f*, and cap *h*, provided with tube *e* and tongue *z*, substantially as and for the purposes herein set forth.

5. The combination, with the crocheted lever A, of the gripe-link J and slotted extension-bar L, as and for the purposes herein set forth.

6. The combination of the crocheted lever A, middle plate I with tenon *v*, the stirrup *t* and plate *w*, with the notched extension-bar L, as and for the purposes herein set forth.

7. The combination of the notched eccentric-rod *b'* with the wheels G, having cog-plates H attached thereto, and the pivoted brace-hooks M, substantially as set forth.

8. The movable bent bar D, formed with shoulders *a a* and sharp edge *b*, in combination with the crocheted lever A, substantially as and for the purposes herein set forth.

9. The movable iron platform, consisting of the cross-bar N, with hooks *e'* and the longitudinal bars O, substantially as and for the purposes herein set forth.

In testimony that I claim the foregoing I have hereunto set my hand this 24th day of March, 1875.

ALMERON MCKENNEY.

Witnesses:

W. A. SKINKLE,
C. L. EVERT.