

W. E. MERRILL.

Head-Light for Steamboats.

No. 162,938.

Patented May 4, 1875.

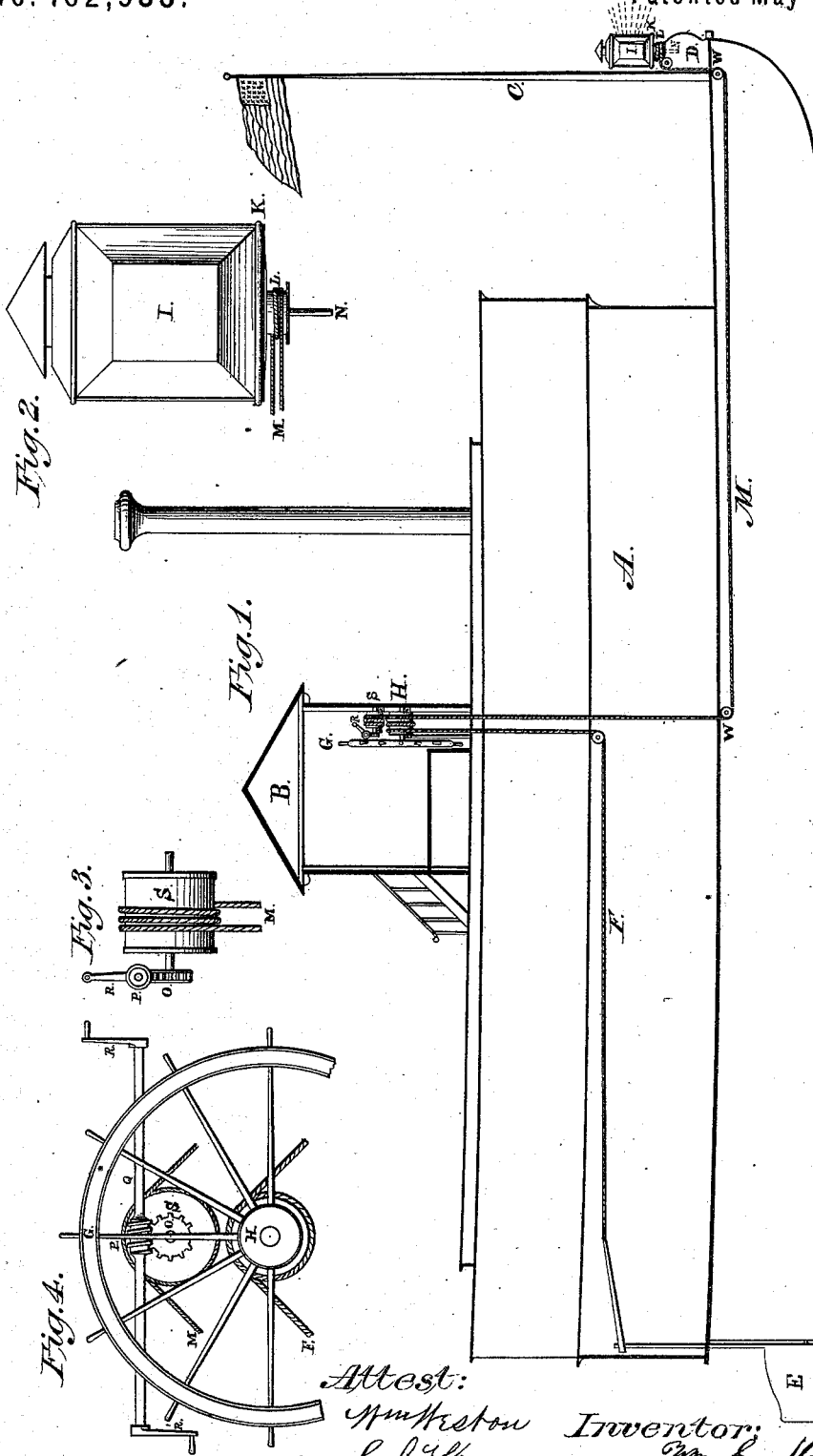

Attest:

*Amherst*  
*R. S. Kinney*

Inventor:  
*W. E. Merrill*

# UNITED STATES PATENT OFFICE.

WILLIAM E. MERRILL, OF CINCINNATI, OHIO.

## IMPROVEMENT IN HEAD-LIGHTS FOR STEAMBOATS.

Specification forming part of Letters Patent No. **162,938**, dated May 4, 1875; application filed January 14, 1875.

*To all whom it may concern:*

Be it known that I, WILLIAM E. MERRILL, of Cincinnati, Hamilton county, Ohio, have invented a new and useful Improvement in Head-Lights for Steamboats, of which the following is a specification:

My invention is an improvement in the class of head-lights which are made capable of being directed at will to any point on the horizon, and consists in devices whereby the direction of the head-light is placed under control of the pilot or helmsman without leaving his post at the wheel.

In carrying out my invention the head-light is placed on the top of the stem, in front of the jackstaff, and, therefore, immediately over the bow of the boat, with nothing whatever in front of it. This position is a necessity, because, if placed anywhere else on the boat, it would certainly be behind the jackstaff and might be behind the spars and other forward rigging. It would therefore light up these uprights and the light would interfere with the clear vision of the pilot. The connections for transmitting motion are passed from the top of the stem through the hold, running aft until a point is reached vertically under the pilot-house and then pass up into the latter. Owing to the length of the connections and the crookedness of the route traveled, powerful gearing is provided in the pilot-house for turning and keeping the light in any desired position. The gearing is arranged relatively to the steering-wheel, so that it can be readily handled.

In the accompanying drawing, Figure 1 is a longitudinal section of a steamboat provided with my invention. Fig. 2 is a side elevation of the lantern or head-light proper, with its attached turn-table. Fig. 3 is a longitudinal elevation of the drum and gearing in the pilot-house. Fig. 4 is a transverse elevation of the same, with a portion of the steering-wheel, looking forward. Fig. 1 is drawn to a smaller scale than that of the other figures.

A represents a steam-boat; B, its pilot-house; C, the jack-staff; D, the stem; E, the rudder; F, the tiller-rope; G, the steering-wheel; H, the tiller-rope drum. I represents my head-light proper or lantern, preferably such as used on locomotives. K is a turn-

table, on which the head-light I is fastened. Attached to the under side of the turn-table is a drum or pulley, L, whose spindle N occupies an orifice or socket, sunk perpendicularly in the top of the stem D, or other fixture of the boat. A rope, M, which encircles the drum L has its two ends conducted around suitable sheaves W to a drum, S, which it similarly encircles, and which is journaled parallel with and immediately over the tiller-drum and forward of the tiller-wheel, as shown in Figs. 1 and 4. On the shaft of the drum S is a worm-wheel, O, in which is engaged a worm, P, at the mid-length of a long horizontal shaft, Q, which has, at its extremities, winches R R'. The above parts are purposely so located as to bring one or other of the winches R R', at all times, conveniently accessible to the pilot, so that whether on the port or starboard side he can, without difficulty, operate the head-light and direct its rays to any point of the horizon, the shaft Q being, for this purpose, placed at the average height of the pilot's hands when standing at the wheel. It will be seen that, by placing the winch-shaft transversely of the steering-wheel, the head-light can be turned by either helmsman, (when two men are required,) so that the one having a hand disengaged can turn the light, it being necessary to adjust the lantern readily and as often as the direction of the vessel requires.

I am aware that revolving head-lights have been heretofore proposed, and, therefore, disclaim invention thereof, apart from my devices for enabling the easy and certain control of the light by a steersman or pilot from his place at the wheel.

My head-light is capable of revolution throughout a full circle, and that from the pilot-house, so that when a pilot gets the light on a snag he is able to follow it as the boat advances, and to keep the light on the snag at least until it is abreast of the wheels. Also in landing and when coaling from a flat alongside he is able to throw the light aft along the side of the boat, so as to light up the gangway and the coal-flat. The light can also be thrown onto the deck when desired. Should the pilot desire to have the light shut off it can readily be done by covering the lens with a cloth, or by closing a blind hinged on one

side, or by dropping a movable slide, or by fastening a screen on the jackstaff and turning the light back into this screen.

I claim herein as new and of my invention—

1. The winch-shaft R R' Q, arranged relatively to the steering-wheel, as described, in combination with suitable ropes M, sheaves W, and turn-table for turning a head-light placed in front of the jackstaff above the stem, substantially as herein set forth, for the purpose designated.

2. A head-light for steamboats and other

water-craft, consisting of a lantern, I, (light on one side only,) attached to a horizontal turn-table, K L N, capable of complete rotation and connected by means of cords M passed under the steamer's deck around sheaves W, with the drum, worm, and winch movements S O P Q R R' in the pilot-house, in manner substantially as set forth.

WILLIAM E. MERRILL.

Witnesses:

WALTER ALLEN,  
HENRY TANNER.