

B. F. STURTEVANT.  
Fan-Blower.

No. 162,968.

Patented May 4, 1875.

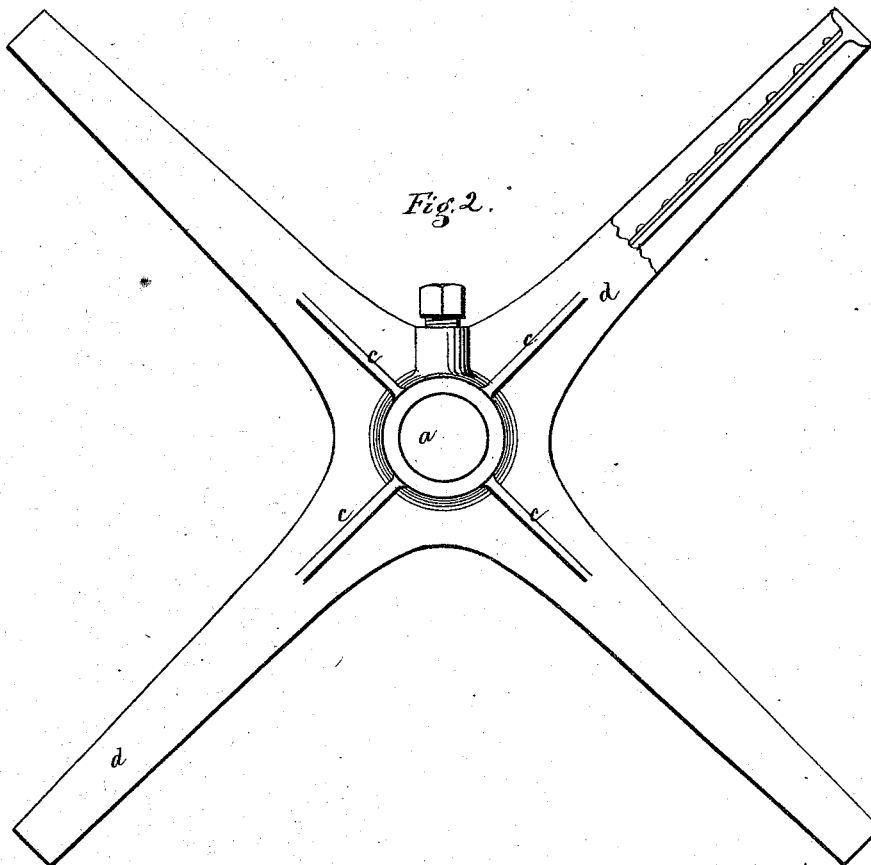
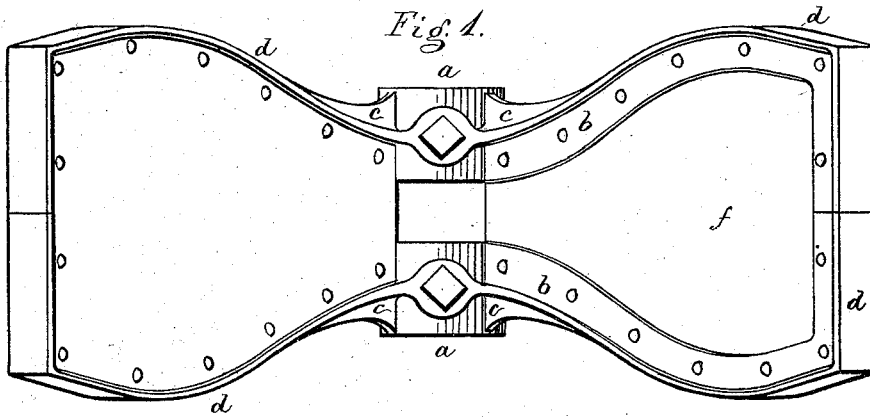

WITNESSES.

*Wm Pratt,*  
*Alfred W. Mudge,*

INVENTOR.

*Benjamin F. Sturtevant*  
PER *Crosby Langory Atty's*

# UNITED STATES PATENT OFFICE.

BENJAMIN F. STURTEVANT, OF BOSTON, MASSACHUSETTS.

## IMPROVEMENT IN FAN-BLOWERS.

Specification forming part of Letters Patent No. **162,968**, dated May 4, 1875; application filed March 27, 1875.

### CASE B.

*To all whom it may concern:*

Be it known that I, BENJAMIN F. STURTEVANT, of Boston, in the county of Suffolk and State of Massachusetts, have invented an Improvement in Fan-Blowers, of which the following is a specification:

In that class of centrifugal blowers which are employed to take from machines waste substances thereby produced—such, for example, as shavings from planing-machines, sawdust from saws, grit, steel, and dust from grinding and polishing machines, &c.—considerable large and heavy matter passes through the blower incidentally and accidentally, such as knots of wood, bolts, nuts, wrenches, tools, and articles operated upon by machines from which the blower is intended to remove only the surplus material. The fan-wheel of the blower, revolving with great velocity, strikes its air-blades against whatever comes into the blower through the exhaust-opening with blows the effect of which is calculated by multiplying the velocity of the blades by the weight of the matter struck, such blows often indenting the blades, perforating them, or breaking them, sometimes resulting in a complete wreck of the blower.

The object of this invention is to strengthen the air-blades of the rotary fans of such blowers against such blows; and the result is accomplished by extending the web and flange of each air-blade-supporting arm from the hub common to all the arms entirely around its sides and outer end, and in this construction my invention consists.

In the drawing, Figure 1 shows my improved construction in elevation, and Fig. 2 in plan.

The spider of the rotary fan-wheel is preferably and commonly made by casting, and, for

convenience of casting, is made in two symmetrical parts. The hub is thus generally separated in its parts, as seen in Fig. 1, and from each part radiate as many arms as may be required, each arm being made webbed and flanged, with a form of section near its root or junction with the hub commonly called "cross," the rest of the sectional form being that known as "tee," the web of each arm serving to receive the fastenings which secure the air-moving plate thereunto, and the arm extending around the sides and outer ends of the plate secured thereunto, thus forming a strengthened edge to each, and reducing the liability of breakage.

In some cases the continuation of the arms supporting the air-plates may be made with secure forms and methods of lapped or scarfed joints at the outer corners of the air-blades, or at any other convenient locations.

*a a* are the hub parts, from which radiate the arms, with webs *b c* near the roots, the web *c* vanishing at some distance from the hub, the flanges *d* extending from one to the other part of the hub, and the plates *f* are fastened to the webs *b*.

I claim—

In the construction of rotary fan-wheels for blowers, the combination of the plates *f* with the hubs *a* by means of webbed and flanged arms, the webs and flanges of which extend from the hubs along the sides and over the ends of the plates, substantially as and for the purpose set forth.

In testimony whereof I have signed my name to this specification in the presence of two subscribing witnesses.

BENJ. F. STURTEVANT.

Witnesses:

J. B. CROSBY,  
S. B. KIDDER.