

J. H. LUKENS.
Railway-Switch Stand.

No. 163,220.

Patented May 11, 1875.

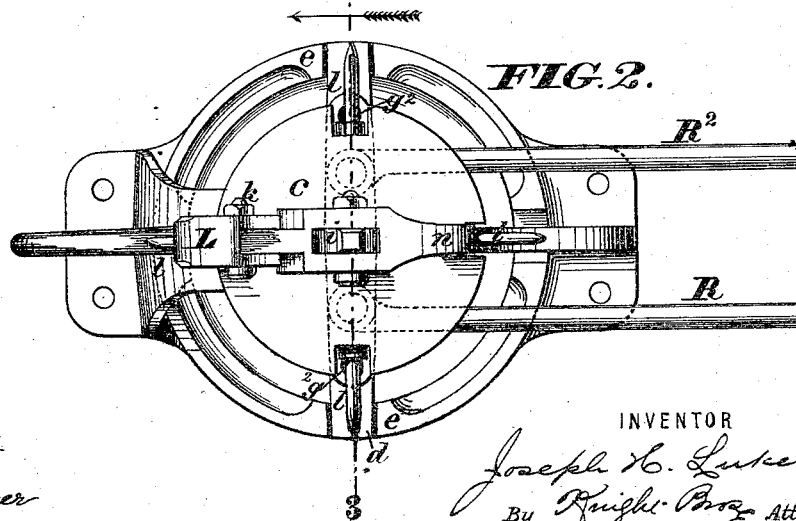
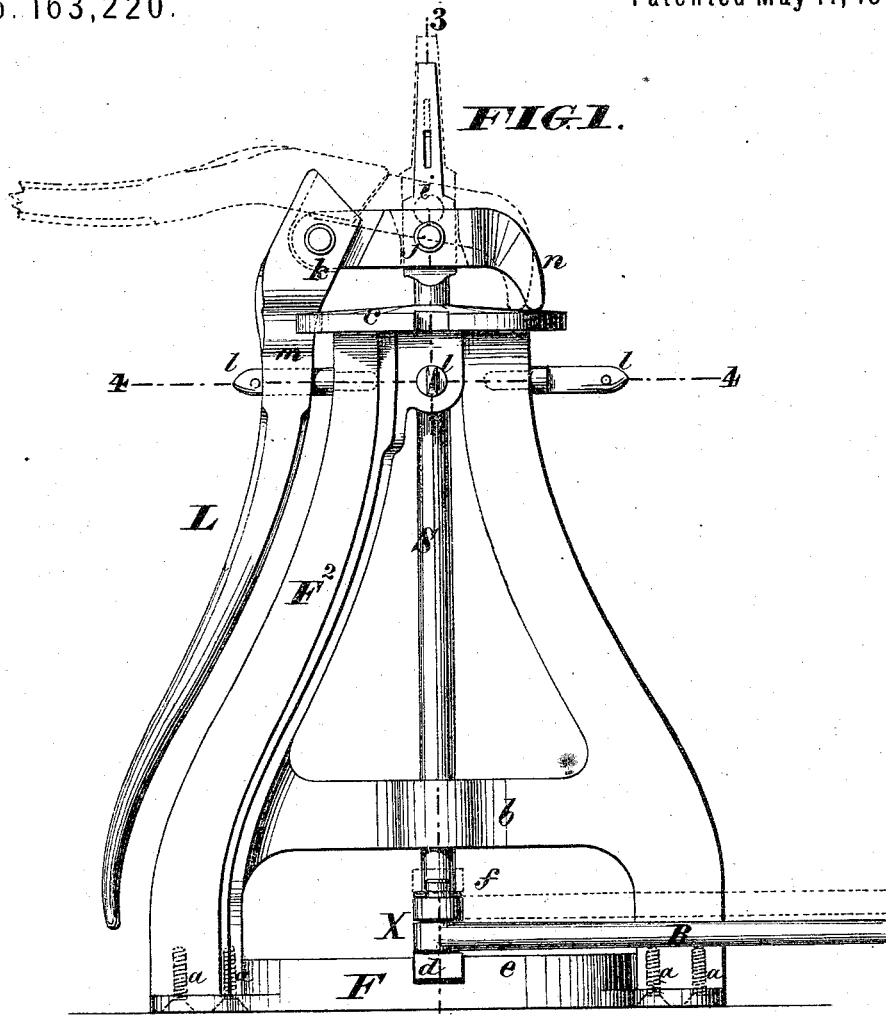

WITNESSES
F. C. Smith
Henry Tanner

INVENTOR
Joseph H. Lukens
By *R. H. Prosser* Attorneys

J. H. LUKENS.
Railway-Switch Stand.

No. 163,220.

Patented May 11, 1875.

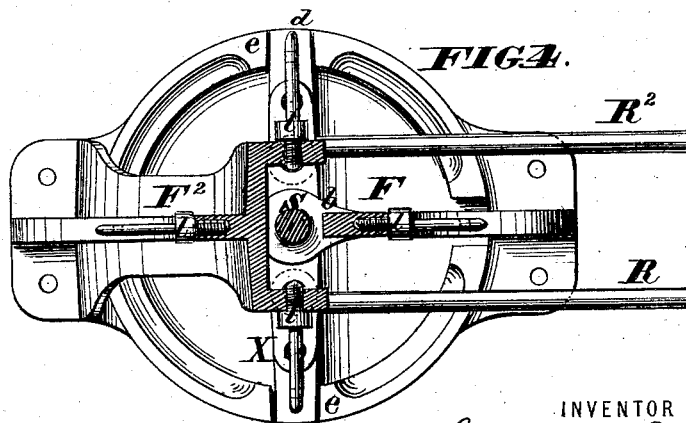
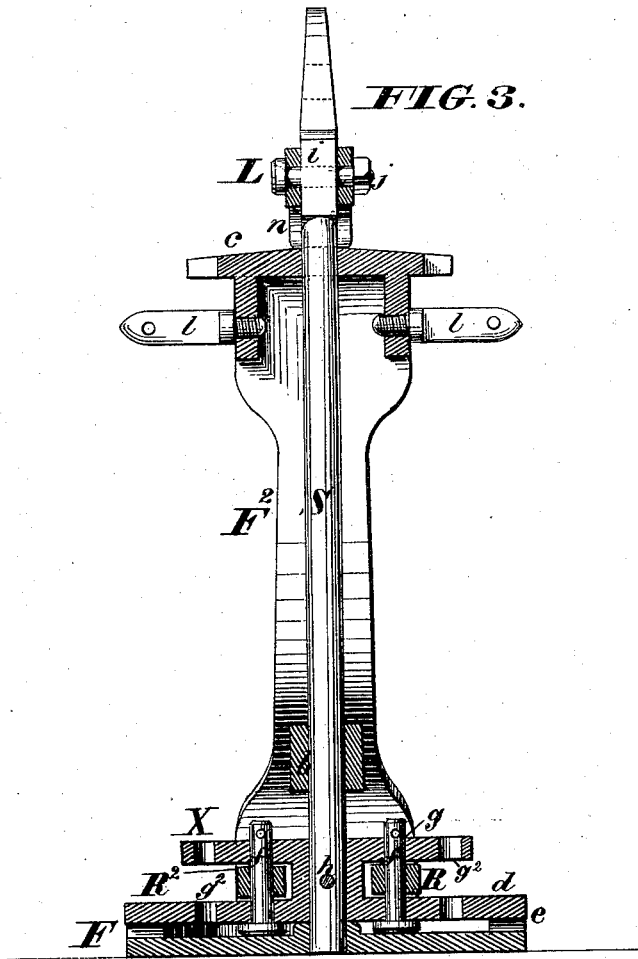

WITNESSES
F. C. Smith
Henry Tanner

INVENTOR
Joseph H. Lukens
By *Haight, Brosg. Attorneys*

J. H. LUKENS.
Railway-Switch Stand.

No. 163,220.

Patented May 11, 1875.

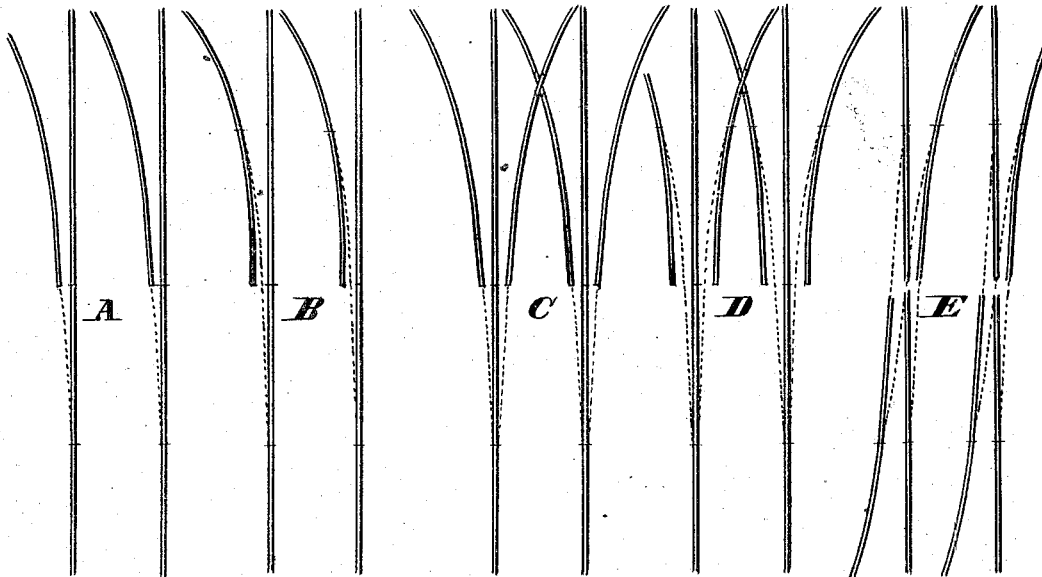
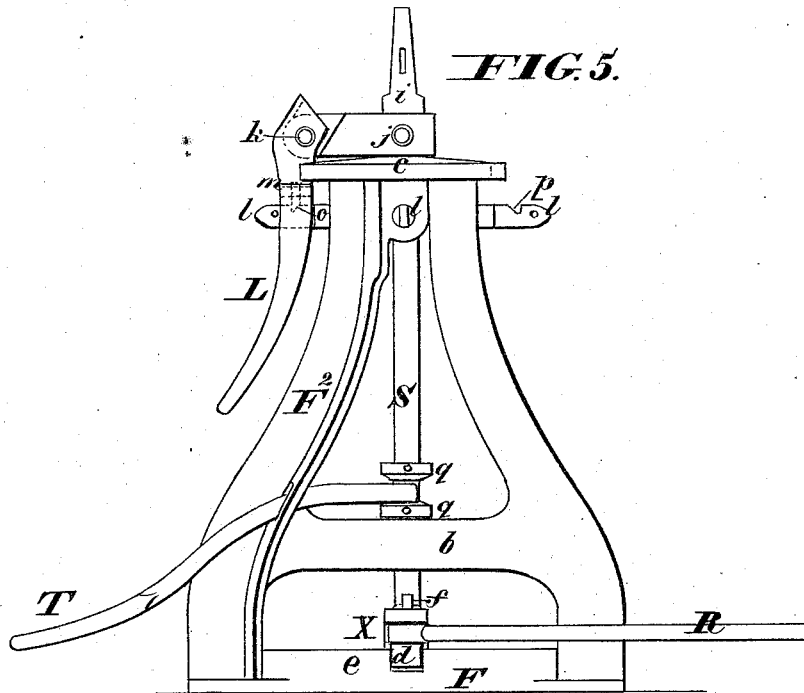

WITNESSES

F. E. Smith
Henry Tamm

INVENTOR

Joseph H. Lukens
By *Freight Broker* Attorneys

UNITED STATES PATENT OFFICE.

JOSEPH H. LUKENS, OF BURLINGTON, NEW JERSEY.

IMPROVEMENT IN RAILWAY-SWITCH STANDS.

Specification forming part of Letters Patent No. **163,220**, dated May 11, 1875; application filed March 5, 1875.

To all whom it may concern:

Be it known that I, JOSEPH H. LUKENS, of the city and county of Burlington, in the State of New Jersey, have invented an Improved Switch-Stand for Railways, of which the following is a specification:

This improved switch-stand is peculiarly simple, compact, and strong in its construction. It is adapted for employment in connection with any of the approved arrangements of switch-rails, and is illustrated in the accompanying drawings, as applied to two-throw and three-throw plain-bar switches with single and double connections, and to a doubledouble plain-bar switch.

The invention relates, primarily, to means for operating double switches, in which, by shortening the throw of the respective bars or switch-rails, easy curves of long radius are formed, and the switches are adapted to transfer trains running at a high rate of speed with safety.

The present invention consists, first, in a base-plate, having a vertical marginal flange, with index-retaining notches therein, in combination with a cross-head at the lower end of a gravitating vertical shaft for locking the latter with great security, and by means which are not liable to remain inoperative without detection, or to be rendered inoperative by the accumulation of ice.

The invention consists, secondly, in a combination of a base plate, having a notched vertical flange, and a double cross-head, adapted to engage therewith, and having provision for attaching the connecting-rods thereto. By these means provision is made for applying the holding device directly to the switch bars or rails, or at the point of their connection with the shaft, by which they are shifted.

The invention consists, thirdly, in a peculiar compound lever attached by a pivot to the upper end of the switching-shaft, and fulcrumed by a projection at one side of the shaft, engaging with the top of the stand-frame or a horizontal disk.

The invention consists, fourthly, in the combination of the said compound lever, a notched disk forming its fulcrum, bearing and operating in connection therewith, as supplemental means for holding the switching-shaft in its

different positions, and padlock-staples arranged in line with the notches to secure the lever therein, and to prevent the elevation of the shaft out of lock.

The invention consists, fifthly, in the combination of a notched holding-disk at the top of the stand, and a folding lever engaging with the notches and having an enlargement to project beyond the walls of the notches beneath the disk, to afford independent means for preventing the elevation of the switching-shaft by jar or strain on the rails should the padlock-staples be broken off.

The invention consists, sixthly, in a mode of applying the bolts and pins, whereby the parts of the stand-frame are united and the connecting-rods attached, so as to preclude their accidental or surreptitious removal or displacement.

Figure 1 is a side elevation of a switch-stand illustrating this invention. Fig. 2 is a plan view of the same. Fig. 3 is a vertical transverse section on the line 3 3, Figs. 1 and 2. Fig. 4 is a horizontal section on the line 4 4, Fig. 1. Fig. 5 is side view of a modified form of switch-stand, embodying some of the features of the present invention.

Diagrams A B C D E represent different forms of switches, to which the improved stand is applicable.

Like letters of reference indicate corresponding parts in the several figures.

The frame of this improved switch-stand consists of two light castings, F F², the first of which is a horizontal base, and the second a skeleton standard properly arched and braced. These are united by screws or bolts *a* introduced upward, as shown in Fig. 1, so that they cannot be removed after the stand is bolted to its foundation-timbers. A bridge-bar, *b*, near the bottom of the standard and an axial hole in its top afford bearings for a central vertical switching-shaft, S, which is adapted to slide longitudinally and to rotate or oscillate. This shaft carries at its lower end a double cross-head, X, and the object of its first motion is to adapt it to carry the extended ends of the lower member *d* of the cross-head, by gravity, into retaining index notches in a vertical marginal flange, *e*, which is cast on the base of the stand-frame. The

object of the rotary or oscillating motion of the shaft is to shift the switch-bars or rails, which are connected to the respective ends of the cross-head by rods $R R^2$ attached by vertical pivot bolts or pins f . Vertical perforations extending through both members of the cross-head receive these pins, and the latter are introduced upward, as shown, so as not to be removable without taking the stand-frame apart. Duplicate perforations $g g^2$ at different distances from the shaft are provided to give the required length of throw for different switches. As adjusted and connected in the illustration, the switch-stand is adapted to operate a double plain-bar switch with single connection, diagram B, or a double plain-bar three-throw switch, diagram D, or a double double plain-bar switch, diagram E. The connecting-rods $R R^2$ are attached to the respective sets of sliding bars or rails, and the switching-shaft S with its cross-head X operates to give the required short throw or throws. These forms of switch have the important advantage of an easy curve of long radius to accommodate trains, running at a high rate of speed, from the main track. The double double plain-bar switch, diagram E, is used instead of two single plain bars, and saves two switch-rails, generally thirty feet each, and one post or stand. The cross-head X is made of cast-steel, so as to possess the required strength, and is securely locked on the switch-shaft by a cross-rivet, h . The top c of the stand-frame is a flat or slightly convex circular disk. Above this the switching-shaft has a head, i , terminating in a tapering slotted tang to receive an ordinary target. The hand-lever L is attached to the head i by a bolt or pin, j , which is riveted or otherwise fastened in place. This lever is constructed with a joint, k , above the outer edge of the top disk c , so as to fold downward, and the projecting edges of said disk are provided with retaining index-notches, corresponding in position with those in the flange e of the stand-base, to receive or engage with the folding portion of the lever when depressed, as shown in full lines in the drawing. (See Fig. 1.)

Padlock-staples l are usually applied in line with the retaining-notches beneath the cap-disk c , and the lever is constructed with a slot to receive the same. The staples and notches support the switching-shaft against endwise and rotary movement, and the application of the padlock precludes the disengagement of the lever from the same. To afford an additional support against the elevation of the switching-shaft, the folding portion of the lever is constructed with an enlargement or shoulders, m , to project beyond the walls of the retaining-notches beneath the cap-disk. The enlargement below the shoulders serves also to accommodate the slot for the reception of the padlock-staples. The lever L , when straightened in horizontal position, as shown in dotted lines in Fig. 1, constitutes convenient means for applying any

required amount of force to the switching-shaft and its cross-head, for moving the switch bars or rails. In the preferred form of the stand, illustrated in Figs. 1 to 4, the attaching bolt or pin j constitutes a pivot, and that section of the lever to which it is applied is extended behind the switching-shaft, and terminates in a downwardly-projecting fulcrum-point, n , which engages with and slides on the cap-disk c . The lever thus constructed serves, in addition to its primary function, as means for elevating the switching-shaft and its cross-head, to disengage the holding-bar of the latter from the notches of the flanged base-plate, as illustrated in Fig. 1. In the modification illustrated in Fig. 5 the hand-lever serves only for turning and holding the switching-shaft, and is provided with an automatic spring-catch, o , to engage with notches p in the padlock-staples A . Treadle T serves for elevating the switching-shaft after it is unlocked. A pair of fixed collars, q , on the switching-shaft, engage with a fork at the inner extremity of the treadle. The shaft and rods of the improved switch-stand, with the pins, bolts, rivets, and staples, may be made of wrought-iron. The other parts, excepting the cross-head X , may be made of cast-iron. The latter, as before stated, is by preference made of cast-steel. It can be made very cheaply of this material, and so as to possess all necessary strength.

The simple operation of the improved switch-stand does not require any separate description.

For operating a single plain-bar switch, (diagram A,) in which the required throw is six inches or thereabout, or a single plain-bar three-throw switch, (diagram C,) in which the required movement is six inches in each direction, the sliding bars or rails are connected to either end of the cross-head X at its outer perforations g^2 . For operating a double plain-bar switch, with single connection, (diagram B,) or a three-throw double plain-bar switch, (diagram D,) or a double double plain-bar switch, (diagram E,) the sliding bars or rails, as before stated, are connected to the cross-head at its inner perforations g , as shown in the drawing.

I am aware that a rotating and gravitating switching-shaft is not broadly new; also, that a compound lever for rotating or for elevating and rotating a vertical switching-shaft, and for locking the same against rotation, is not new; and these features of my improved switch-stand, in themselves considered, are hereby disclaimed. I am aware of the peculiar elevating and turning lever, shown and described in United States Patent No. 144,880, issued November 25, 1873, to Joseph Wood. My compound lever differs therefrom, in that it is pivoted directly to the gravitating-shaft and has its fulcrum behind the same. I thus economize space, so as to be able to employ a lever of greater length than would be otherwise practicable, so as to obtain more lever-

age, and I apply the power directly to the gravitating-shaft, instead of through the medium of a rigid arm. My locking devices differ from those shown in this patent, in that they provide for securing the gravitating-shaft against elevation, as well as against rotation, thus insuring themselves against wrenching strains.

The following is claimed as new, namely:

1. The base-plate F, having a vertical marginal flange, *e*, with index-notches therein, in combination with a cross-head, X, at the lower end of the gravitating switching-shaft, engaging at each end with the said notches for holding the switching-shaft in its different positions, in the manner herein specified.

2. The combination of the base-plate F, having the notched vertical flange *e e*, and a double cross-head adapted to engage therewith, and having provision for attaching the connecting-rods directly thereto, as herein shown and described, for the purpose set forth.

3. The improved elevating and turning lever L, attached by a pivot to the upper end of the gravitating switching-shaft, and fulcrumed by a projection, *n*, behind the shaft, engaging with the cap-disk *c* of the stand-frame, as herein shown and described, for the purpose stated.

4. The notched cap-disk *c*, and the locking-staples *l* (one or more) arranged in line with the notches, in combination with the elevating and turning lever L, articulated and slotted, as described, and the gravitating switching-shaft S, carrying the holding cross-head X, for insuring the descent of the latter into lock, and securing the switching-shaft against elevation and rotation, as herein specified.

5. The combination of the notched holding-disk *c* at the top of the stand, and the holding-lever L engaging with the notches, and having an enlargement or shoulders, *m*, to project beyond the walls of the notches beneath the disk, as described, for the purpose set forth.

6. The bolts and pins *a f*, by which the parts of the stand-frame are united, and the connecting-rods are attached to the cross-head of the switching-shaft, the same being applied from beneath upward, as shown and described, so as to be protected against accidental or surreptitious removal or displacement, as set forth.

JOSEPH H. LUKENS.

Witnesses:

R. D. KEAN,
J. H. HOUGH, Jr.