

H. P. OHM.
Fire-Place Stove.

No. 163,235.

Patented May 11, 1875.

Fig. 1

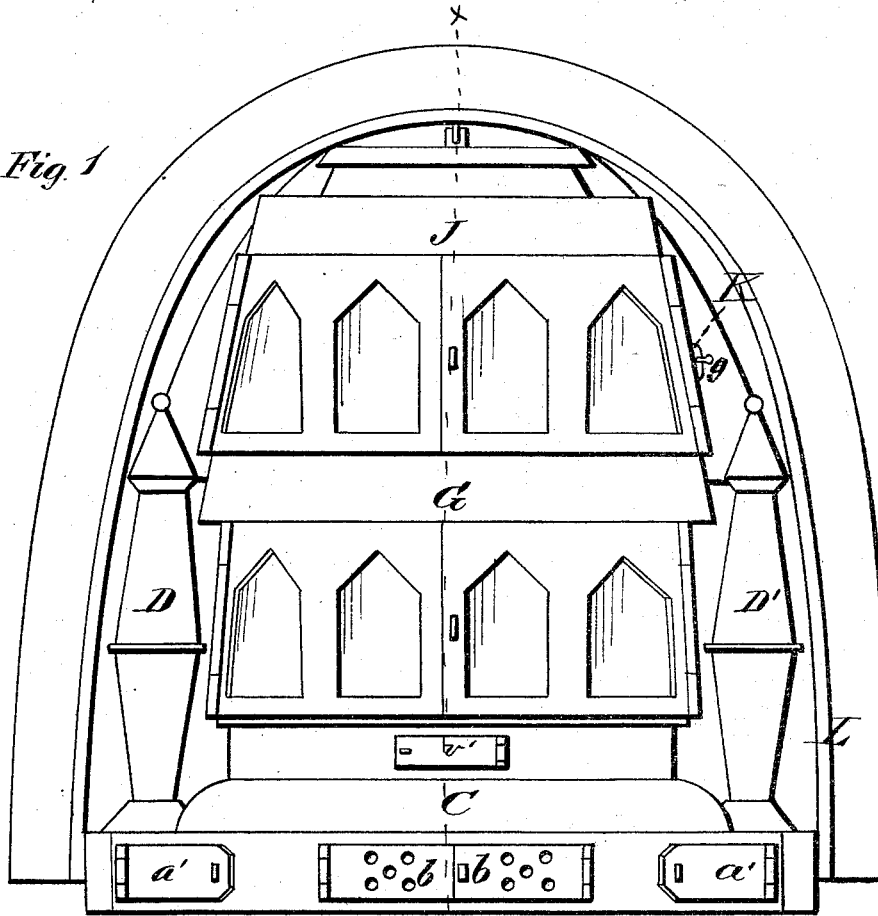
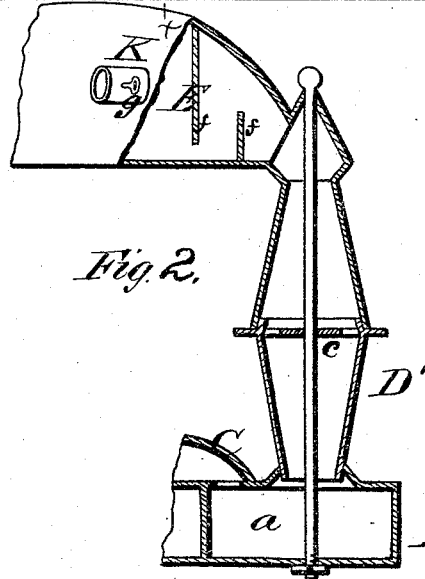

Fig. 2.



WITNESSES
E. H. Bates
George C. Wehner

INVENTOR
Henry P. Ohm,
A. Chipman for me &c.

ATTORNEYS

H. P. OHM.
Fire-Place Stove.

No. 163,235.

Patented May 11, 1875.

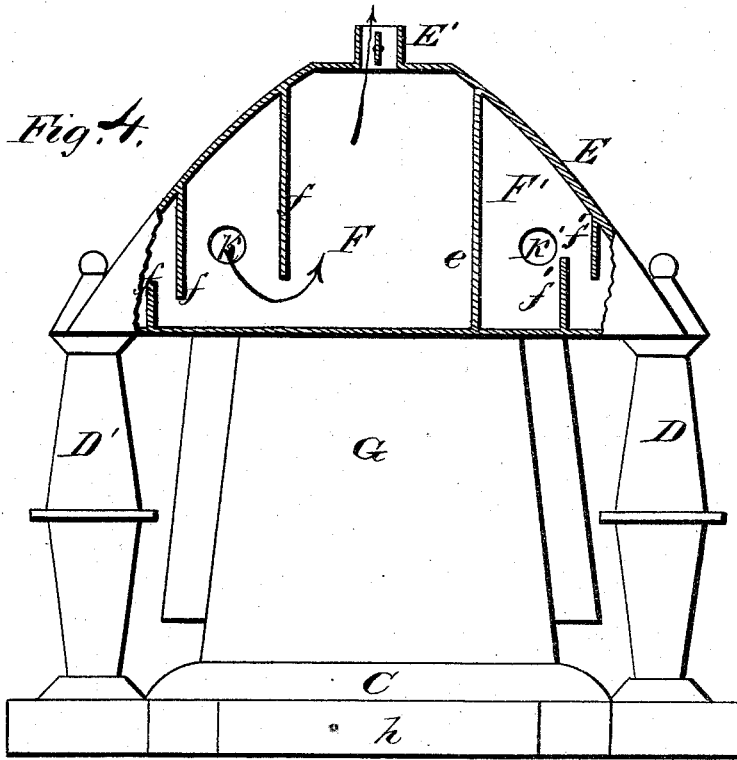

WITNESSES

E. A. Bates
George C. Upham

INVENTOR

Henry P. Ohm,
Chipman & Co.,
ATTORNEYS

H. P. OHM.
Fire-Place Stove.

No. 163,235.

Patented May 11, 1875.

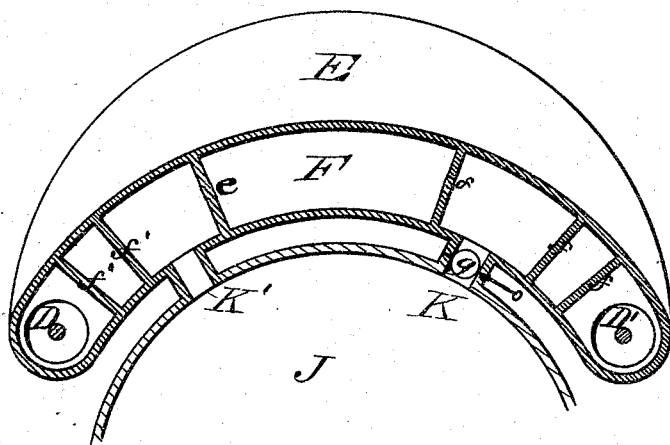

Fig. 5.

WITNESSES
E. A. Bates
Eug. W. Johnson

INVENTOR
Henry P. Ohm.
Chipman Fosmer & Co
ATTORNEYS

UNITED STATES PATENT OFFICE.

HENRY P. OHM, OF BALTIMORE, MARYLAND, ASSIGNOR OF ONE-HALF HIS RIGHT TO ALVA HUBBARD, OF SAME PLACE.

IMPROVEMENT IN FIRE-PLACE STOVES.

Specification forming part of Letters Patent No. 163,235, dated May 11, 1875; application filed April 7, 1875.

To all whom it may concern:

Be it known that I, HENRY P. OHM, of Baltimore, in the county of Baltimore and State of Maryland, have invented a new and valuable Improvement in Stoves; and I do hereby declare that the following is a full, clear, and exact description of the construction and operation of the same, reference being had to the annexed drawings making a part of this specification, and to the letters and figures of reference marked thereon.

Figure 1 of the drawings is a representation of a front view of my improved fire-place stove. Fig. 2 is a detail vertical section of a radiating column. Fig. 3 is a central vertical section taken through line *x x* in Fig. 1. Fig. 4 is a rear view, showing the radiating-box in section. Fig. 5 is a horizontal cross-section taken through line *y y* in Fig. 3.

This invention has relation to that class of stoves which are denominated fire-place heaters; and the nature of my invention consists in outstanding heat-radiating columns forming part of the indirect draft-flue and provided with deflectors for deflecting the heated products of combustion outward against their swelled walls; also, in a heat-radiating box provided interiorly with divisions and forming a communication between the combustion-space and the smoke-pipe, said box being located at the rear of said space, out of sight and out of the way; and also in the novel construction of the parts, as will be hereinafter more fully described.

In the annexed drawings, A designates the base-section of the stove, in which is the ash-drawer B, and on top of which an annular heat-radiating flue, C, is formed, which communicates, by means of chambers *a*, with the lower ends of two columns, D D'. The chambers *a* are provided with doors *a'* for allowing the removal of soot, &c., which accumulate in them, and the ash-pit is provided with doors *b*, in which registers are applied. The columns D D' are cones applied base to base, and at their largest parts horizontal deflectors *c* are applied, the object of which is to direct the descending and ascending currents of heated products outward, and thus utilize all the heat possible and make the columns, which

stand well out in the room, heat-radiators. E designates a radiator-box of crescentic form, the front ends of which are supported upon and communicate with the upper ends of the columns D D', and the rear part of which is supported upon a bracket, *d*. At the middle of the upper edge of the radiator E is a smoke-pipe, E', which is provided with a damper controlled by a rod extended forward over the top of the stove. The radiator E has a vertical partition, *e*, in it, on one side of the pipe E', on each side of which are vertical plates *f*, which form diving-passages for the products of combustion. The partition *e* divides the radiator into two chambers, F F', shown in Fig. 4. G designates the second section of the stove, in which the fire-pot H is suspended, and J designates the top section of the stove, forming a combustion-chamber. Both sections G and J are provided with doors having mica lights in them, which expose to view the fire in both sections. K is a short pipe leading from the interior of section J into the chamber F in the radiator, and provided with a damper, *g*, which, when opened, will give a direct draft to the smoke-pipe E'. When the damper *g* is shut the products of combustion pass through a short pipe, K', into the chamber F' in the radiator E, thence down through the column D into chambers *a*, thence through the heat-radiating flue C, thence up through the column D' into the chamber F, and finally out through the pipe E'. The heated products are thus conducted twice into the radiator E, through both columns D D' and through the base top-draft radiator C, before they are allowed to escape from pipe E'. L designates the casing or jacket in which the stove is placed for the purpose of forcing the heat into the room, and *h* designates a space which is formed by contracting the back of the base A, for allowing the ascending currents of cool air to impinge against the overhanging bottom of the flue C, as shown by the arrows in Fig. 5. The air will thus be heated on its first entrance into the jacket L, and cold currents of air will be prevented from impinging on the wall of section G. The rear portion *j* of the top plate of section J is inclined, as shown in Fig. 5, for the purpose of allowing the heated air from

the back of the stove to pass freely over it and into the room, and be subjected to the heat of this inclined plate *j*. The front part of plate *j* may be suitably ornamented to give a neat finish to the top of the stove. The upper part of the fire-pot H is a cylinder, the upper edge of which is flanged and sustained by the flanges *i*, resting upon an annular perforated shelf, *k*, through which and also through an inclined ring, *l*, currents of highly-heated air are allowed to pass and mix with the gases in the combustion-chamber in section J. The lower part of the fire-pot is composed of bars *n*, a ring, *m*, and a grate, N, which latter can be tilted as well as shaken horizontally. At the front of the grate N is a loop or eye, *t*, and at the front of the base-section, just above the radiator C, is an opening, *v*, provided with a door, *v'*. This opening is below the mica doors of the section G, and when a rod is introduced through it the attendant can see how to direct this rod into the loop *t* without opening the doors of section G.

What I claim as new, and desire to secure by Letters Patent, is—

1. Outstanding heat-radiating columns DD',

forming part of the indirect draft-flue, in combination with deflectors *c*, substantially as described.

2. The heat-radiating box E, divided as described, in combination with the combustion-section J and the escape E', substantially as described.

3. Outlets K K', combined with the combustion-chamber section J and radiator E, divided as described.

4. Chambers *a a*, columns D D', flue C, and radiator E, combined with outlet-pipes K K' and damper *g*, substantially as described.

5. The cylindrical section H of the fire-pot, provided with the flange *i* resting on the annular perforated shelf *k*, in combination with the inclined perforated ring *l* and combustion-chamber J, substantially as described.

In testimony that I claim the above I have hereunto subscribed my name in the presence of two witnesses.

HENRY P. OHM.

Witnesses:

GEORGE E. UPHAM,
JOS. B. LOOMIS.