

J. K. PROCTOR.
Wool-Washing Machine.

No. 163,250.

Patented May 11, 1875.

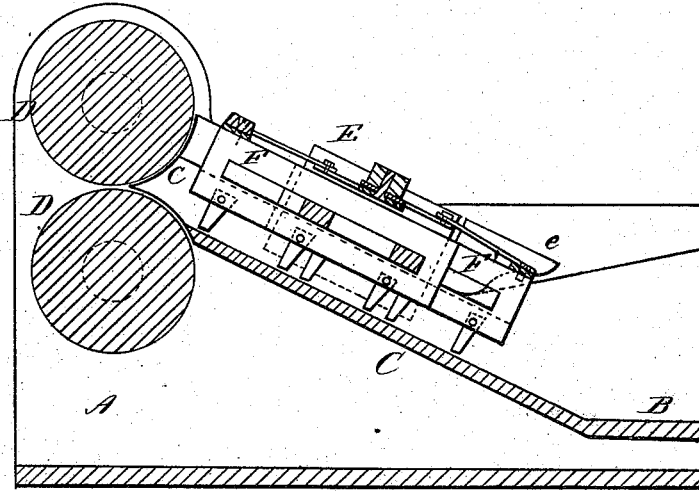

Fig. 1

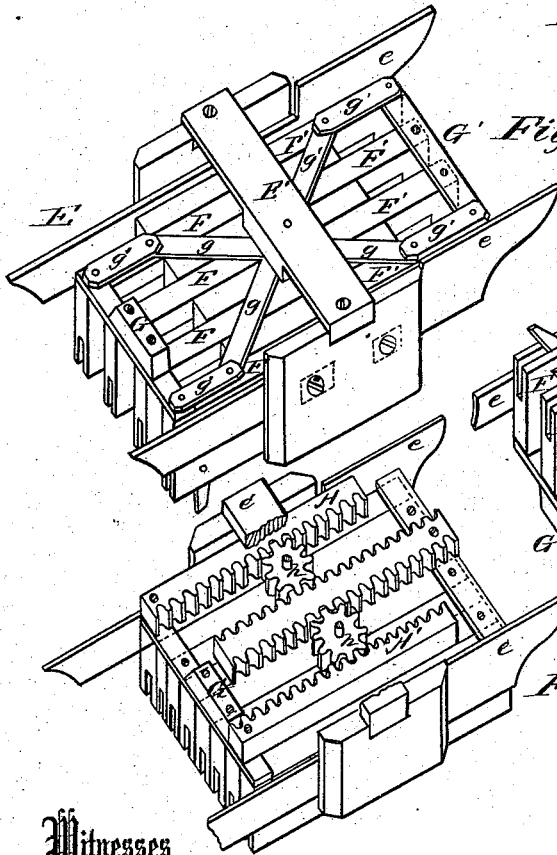

Fig. 2

Fig. 3

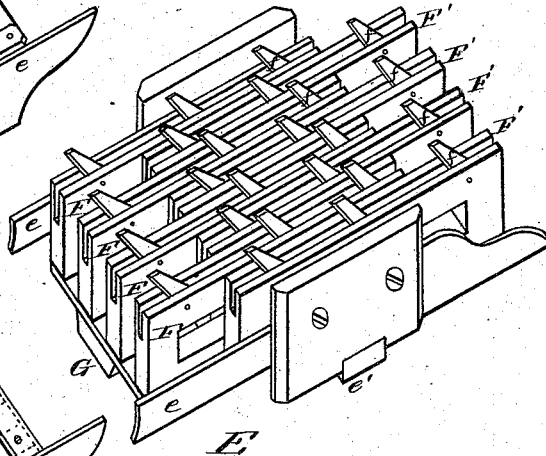

Fig. 4

Witnesses

S. J. Van Stammers
Jas. P. Connolly

Inventor

Josiah K. Proctor,
Connolly Bros., Attorneys

UNITED STATES PATENT OFFICE.

JOSIAH K. PROCTOR, OF PHILADELPHIA, PENNSYLVANIA, ASSIGNOR OF
ONE-HALF HIS RIGHT TO JAMES SMITH & CO., OF SAME PLACE.

IMPROVEMENT IN WOOL-WASHING MACHINES.

Specification forming part of Letters Patent No. **163,250**, dated May 11, 1875; application filed
April 28, 1875.

To all whom it may concern:

Be it known that I, JOSIAH K. PROCTOR, of Philadelphia, in the county of Philadelphia and State of Pennsylvania, have invented certain new and useful Improvements in Wool-Washing Machines; and do hereby declare the following to be a full, clear, and exact description of the invention, such as will enable others skilled in the art to which it pertains to make and use it, reference being had to the accompanying drawings, which form part of this specification, in which—

Figure 1 is a longitudinal vertical section; Figs. 2 and 3, perspectives of the carrier; Fig. 4, perspective of rack and pinion carrier.

My invention has for its object to provide a continuous feed for a wool-washing machine.

The nature of my invention consists in the peculiar construction and combination of parts, as hereinafter fully described, having reference particularly to the device known as the "carrier," by which the wool is lifted from the bowl or tank to the squeeze-rollers. This carrier, as I construct it, is composed of a rigid frame placed above the chute or incline leading from the false or supplemental bottom to the squeeze-rollers. Within this frame are set two series of parallel bars provided with downwardly-projecting hinged or swinging teeth, said bars being constructed and arranged in such manner that they can be reciprocated alternately in a longitudinal direction, their teeth engaging with the stock on their upward movement, and yielding so as to slide over said stock on their downward movement.

Referring to the accompanying drawing, A shows the tank or bowl of a wool-washing machine, having a false bottom, B, incline C, and squeeze-rollers D D. E is the carrier, having rigid sides *e e*, which rest on the sides *e e* of the chute C, said sides being connected by a cross-beam or girder, *e'*. F and F' represent two series of parallel bars arranged between the sides *e e*, and provided with downwardly-projecting pivoted or swinging teeth *f f'*, which will engage with the stock on the incline on their upward movement toward the squeeze-rollers, but will rise to clear or pass over said stock on their downward movement toward the bottom of the bowl. G represents

a cross-head secured to the bars F, and designed to be connected with a fork or other equivalent wool-deliverer in such manner that said bars will be reciprocated longitudinally over the incline C. G' represents another cross-head, to which are secured the bars F'. The cross-heads G and G' are connected by the arms *g g'* in such manner that they will move simultaneously in opposite directions, thus inducing a similar or alternately-reciprocating movement in the bars F and F', to which they are respectively secured.

The effect of the foregoing construction is that a carrier having a continuous and uniform feed is produced, for while one series of bars, F, are moving up the incline, the other series, F', are moving down, the last being ready to begin their upward motion as soon as the others begin to go down. In this way the stock is presented to the squeeze-rollers in a sheet or mass only half as deep or thick as would be the case if all the bars F F', or the whole carrier, moved together, which is a great desideratum in wool-washing machines, as it produces a more perfect result of the squeeze-rollers, which cannot perfectly express the liquid from thick masses or lumps of stock. Another advantage of this construction and arrangement is that the employment of retaining studs or teeth on the incline is wholly dispensed with, the teeth of one of the series of bars being always in position to prevent the wool sliding down the incline.

I am well aware that reciprocating bars have been heretofore employed as carriers in wool-washing machines, but that they were arranged in such manner that their teeth projected upwardly, and in their operation the wool was carried up over them. This arrangement is open to the grave objection that as the stock is worked over the bars the latter will speedily become clogged and choked up, requiring constant cleaning, an objection to which my arrangement is not open. I am also aware that previously to this invention of mine a carrier provided with pivoted or swinging teeth was known and used, and, therefore, I do not here, broadly, claim the same. As an equivalent and preferable method of producing an alternate reciproca-

tion of the bars F F', I employ the devices shown in Fig. 4, consisting of the racks H and H', gearing with the pinions *h h* secured to the cross-beam *e'*.

What I claim as my invention is—

1. In a wool-washing machine a carrier provided with two series of alternately-reciprocating bars, F F', having downwardly-projecting hinged or swinging teeth *f f*, substantially as shown and described.

2. In combination with the incline C, the fixed carrier E, provided with the reciprocating bars F moving over said incline, substantially as shown and described.

3. In combination with the bars F and F' secured to the cross-heads G and G', the arms *g g'* for producing an alternate reciprocation of said bars, substantially as shown and described.

In testimony that I claim the foregoing I have hereunto set my hand this 24th day of April, 1875.

JOSIAH K. PROCTOR.

Witnesses:

M. DANL. CONNOLLY,
GEO. C. SHELMEKDINE.