

I. W. DOEG.  
Machine for Making Washers.

No. 163,303.

Patented May 18, 1875.

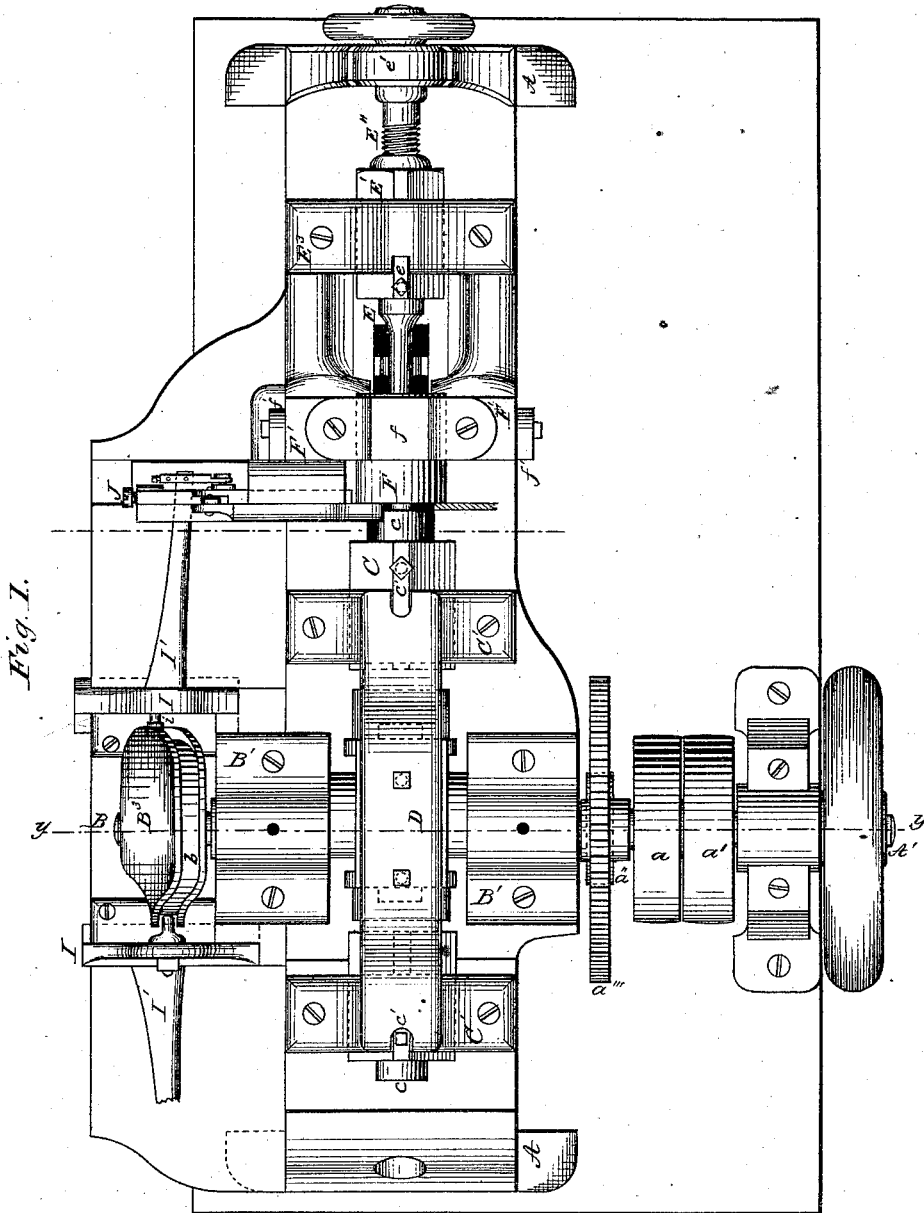

Witnesses:  
J. C. Brecht.  
E. F. Hodges.

Inventor:  
Isaac W. Doeg  
By N. Crawford  
att'y.

I. W. DOEG.  
Machine for Making Washers.

No. 163,303.

Patented May 18, 1875.

Fig. 2.

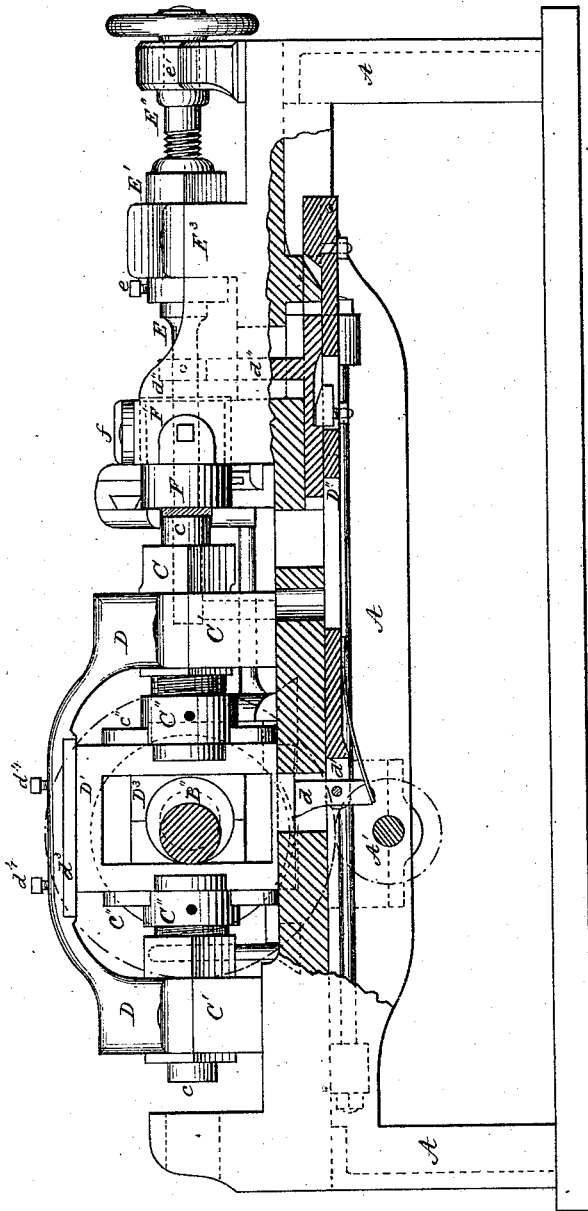
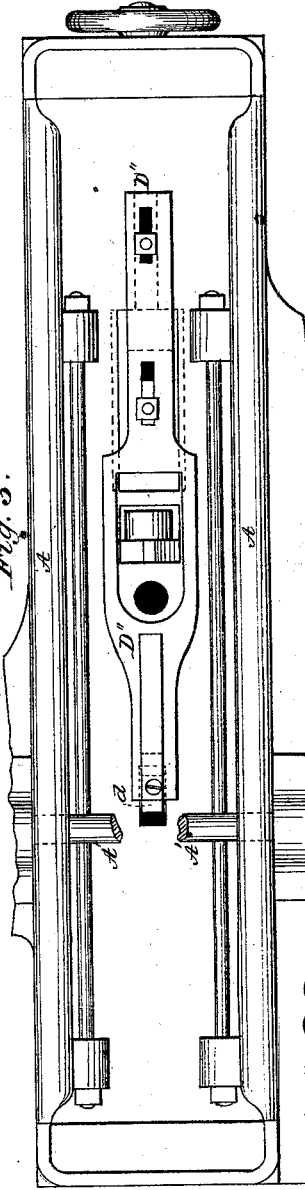

Fig. 3.



Witnesses:

J. C. Drecht.  
C. F. Hodges.

Inventor:

Isaiah W. Doeg  
By N. Crawford  
att'y.

I. W. DOEG.  
Machine for Making Washers.

No. 163,303.

Patented May 18, 1875.

Fig. 4.

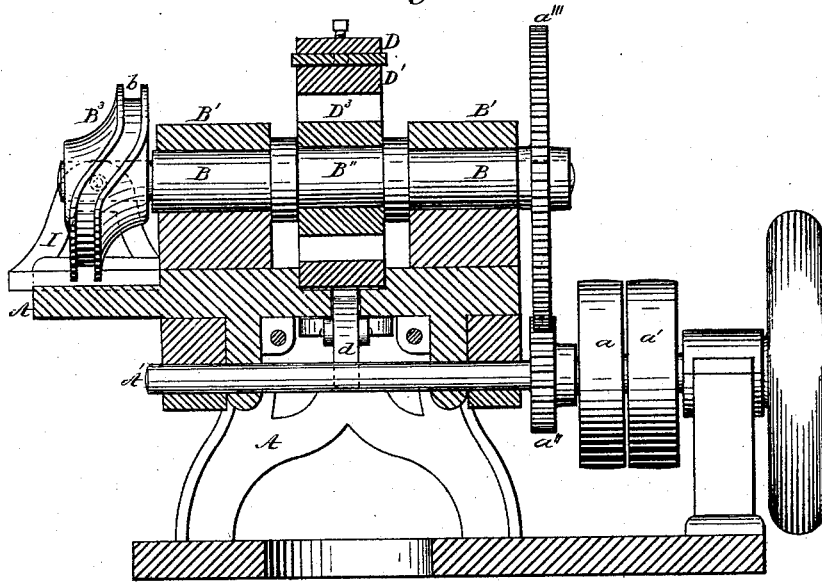

Fig. 5.

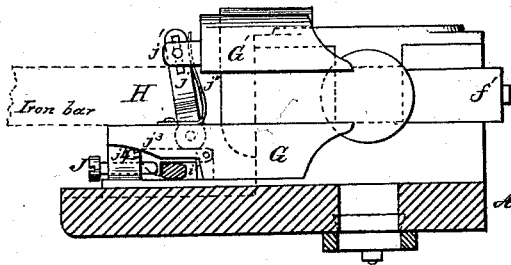

Fig. 6.

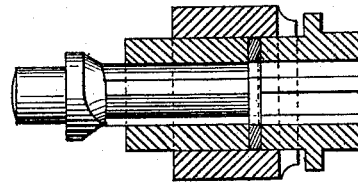

Fig. 7.

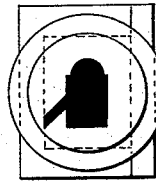

Fig. 8.

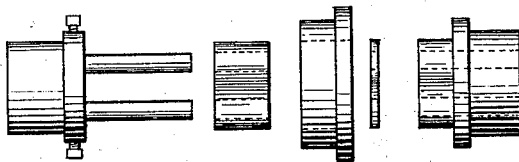

Fig. 9.

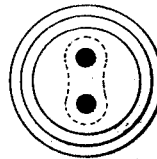
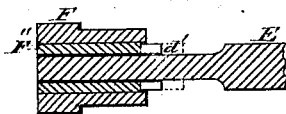

Fig. 10.



Witnesses:

J. C. Brecht.  
C. F. Hodges.

Inventor:

Isaiah W. Doeg  
By N. Crawford  
att'y.

# UNITED STATES PATENT OFFICE.

ISSACHAR W. DOEG, OF NEW MARKET, NEW HAMPSHIRE, ASSIGNOR OF ONE-HALF HIS RIGHT TO ORRIN MURRAY, OF SAME PLACE.

## IMPROVEMENT IN MACHINES FOR MAKING WASHERS.

Specification forming part of Letters Patent No. **163,303**, dated May 18, 1875; application filed December 29, 1873.

*To all whom it may concern:*

Be it known that I, ISSACHAR W. DOEG, of New Market, in the county of Rockingham and State of New Hampshire, have invented certain Improvements in Machines for Cutting and Punching Nuts, Washers, Buckles, Chain-Links, and other analogous articles, of which the following is a specification; and it consists in the construction and arrangement of parts of the machine, as will be fully hereinafter described.

In the drawings, Figure 1 represents a top view of the machine; Fig. 2, a longitudinal, partly sectional, side view; Fig. 3, a bottom view; Fig. 4, a transverse sectional view; and Figs. 5, 6, 7, 8, 9, and 10, details.

A represents the supports and bed or table upon which the actuating parts of the machine rest; A', the main driving-shaft, placed transversely or across the machine, journaled and working in proper bearings, and having the fast pulley *a* firmly fixed thereto, and loose or idle pulley *a'* by the side of pulley *a*. *a''* is a toothed wheel fast on shaft A', gearing into and driving toothed wheel *a'''*, fast on transverse shaft B, which is journaled and works in bearings in blocks B' B', having their supports on the bed A. Centrally between the blocks B' B' shaft B is formed to have a crank or eccentric, B''. B<sup>3</sup> is a cam fast on, and revolves with, shaft B, with a groove, *b*, in its periphery, of irregular form, so as to give to a pin working therein a reciprocating motion parallel with shaft B. C is an adjustable reciprocating punch-stock, sliding in a proper bearing C', that is fast on the bed-plate A, and having the hollow punch-die *c* inserted at its outer end, in the usual way, and held by the holding-screw *c'*, while C'' is a nut, into which the stock C is screwed, and by which it is adjusted. By turning the nut C'', which will, when turned in one direction, force the stock C out, or by turning the nut in the opposite direction, the stock will be drawn into the nut; and, when adjusted to the right position, the arm *c''* is screwed fast to a reciprocating yoke. D is an arch-support, reaching from, and fast at each end, to the bearing-blocks C'. D' is a longitudinal sliding yoke, containing the box in which the crank B'' of shaft B revolves. It is united to the nuts C'' of the punch-stocks C,

and reciprocates therewith. An arm, *d*, that is fast to the under side of the yoke D', extends downward through the bed A, and connects, by pivoting at *d'*, to a sliding frame, D'', on the under side of the bed A. This frame D'' extends some distance underneath the bed, to and beyond where an upright fork, *d''*, is secured in a slot, so that said fork *d''* can be adjusted horizontally. *d'''* is a steel plate inserted between the arch-piece D and yoke D', and is adjusted to the yoke by the set-screws *d<sup>4</sup> d<sup>4</sup>*, which also act as guideways. D<sup>3</sup> is the journal-box in which the crank B'' revolves. This journal-box freely slides up and down within the yoke D', and reciprocates horizontally with it. E is an adjustable idle punch, held in stock E' by the holding-screw *e*, and is adjusted longitudinally by temper-screw E'', working through head-stock *e'*, while the stock E' is held in position by the head-stock E<sup>3</sup>, and the punch E by the stock E' at its rear end, and by a sliding sleeve at its forward or working end, and passing between the two limbs of the fork *d''*. F is a fixed hollow cylindrical die, firmly secured in head-stock F', and held in its place by the keeper *f* and adjustable blocks *f' f'*. F'' is a cylindrical sleeve that freely slides within the die F and upon the idle punch E, and slides within the die to the extent of the thickness, or nearly the thickness, of the nut or washer that is to be punched. G is a carriage, in which the iron bar H is placed on edge, and from which the washer or other thing is to be cut and punched, and is composed of two parts, G and G', G being the lower part or jaw on which the iron bar rests, and G' the upper part or jaw that rests upon the edge of the iron bar, and is adjusted up or down on part G to accommodate the width of the bar of iron, and so as to hold the bar firmly when feeding, and part G, carrying part G' and the iron bar, reciprocates upon or in ways in bed-plate A. The part G' is again in two parts, one sliding on the vertical face of the other, and the jaw that clamps upon the edge of the iron bar is constructed to bear upon the iron bar at its forward end when feeding the bar forward to tilt and ease the jaw off of the iron when the carriage recedes. I is a head-stock freely sliding on ways or in a groove in bed-plate A. At its upper end projects a pin,

*i*, having a friction-roller upon it, that enters into, and works in, the groove *b* of the cam B<sup>3</sup>. I' is a horizontal arm projecting from the head-stock I in a direction longitudinally with the bed-plate A, and through a slot, *i'*, in the lower part G of the carriage that carries the iron bar, as seen in Figs. 1 and 5. J is a set-screw, placed in the lower part of the carriage G, and adjusts the length of the slot in which the arm I' works, and controls or limits the play of arm I' in the slot *i'*. *j* is an inclined link, pivoted to the lower part of the sliding carriage at its lower end, and to an arm or projection, *j'*, on the sliding jaw part of G' of carriage G. *j''* is a spring applied to link *j* to keep it in place, and to aid in throwing the sliding jaw on the top edge of the bar into the proper position for clamping the bar upon it when it is again fed forward to the punch. *j*<sup>3</sup> is a latch, pivoted at its inner end to link *j*, bears upon the top side of arm I', and has a projection at its outer end in a downward direction, so that the arm I' will strike it when it moves the carriage G outward, or the lower part of link *j* below its pivoted point when it moves the carriage forward to feed the bar to the punch.

At the outer end of latch *j*<sup>3</sup> is a temper-screw, *j*<sup>4</sup>, to nicely adjust the throw of the lever to operate the carriage in its backward movement and release the clamping-jaw G' from the edge of the bar. When the end of arm I' strikes the lower end of the link *j* the iron bar will be again clamped and fed forward to the punch.

By this construction and arrangement the feeding of the iron bar to the punch is adjusted to feed just enough, so that no waste of metal need result.

The machine, as described and shown, is for making round washers; but without any change of principle, either in the construction or operation, but only changing the form of the dies and punches, a variety of shapes and different articles can be made, as square nuts or rectangular buckles for cotton-bale ties, or links to chains having two holes therein, merely by taking out the fixed die F, sleeve F', and punching-die *c*, and substituting therefor the punch and die seen in enlarged Figs. 6 and 7, that will cut the buckles for cotton-bale ties, or for those seen in Figs. 8 and 9, for making links to chains.

In the drawings one machine only is fully shown while parts of an opposite machine operated by the same crank-shaft is seen; and it is obvious that not only two machines, one opposite the other, can be successfully operated, but by extending the crank-shaft any number, limited only by the power, can be driven from the one shaft.

The operation of the machine is as follows: The iron bar from which washers are to be made is placed in the carriage, as seen in Fig. 5. The crank-shaft, put in motion, revolves the cam on the end of said crank-shaft, which causes the arm to feed the carriage with iron

bar forward, when the motion of the carriage is stopped. At this instant the crank-shaft is advancing the punch and die forward against the iron, and forces it against the opposite fixed die, and cuts the diameter of the washer in the fixed die, and as the washer is so cut from the bar it bears against the cylindrical sleeve in the fixed die, and moves it back the thickness of the washer, and upon a fixed punch, that cuts or punches the center hole in the washer. At this instant the crank-shaft, in its revolution, has advanced so as to cause the moving punch and die to have a backward movement, forcing the punch and die out of contact with the fixed die and bar of iron or washer, when the frame on the under side of the bed-plate is, by the action of the yoke about the crank, made to reverse its movement, and with it the upright fork that bears against the sleeve in the fixed die, forcing it back, carrying the finished washer on its face, until the sleeve is flush with the face of the fixed die, when the washer falls off down through a hole in the bed-plate upon the floor, and the small piece punched out of the center of the washer is in the moving punch and die, or is forced back and drops out down through a hole in the lower side of the punch-stock, thence through a hole in the bed-plate. While this reactionary movement has taken place, the revolution of the cam has caused the carriage to be forced back and take a new hold upon the bar, and again feed it forward the right distance by the time the forward movement of the punch and dies has again reached the bar, thus automatically feeding and cutting and punching the entire bar, of whatever length, into washers.

Having thus described my invention, what I claim, and desire to secure by Letters Patent, is—

1. As an improvement upon the combination composed of the hollow punch *c*, reciprocating stock C, yoke, D', and their actuating parts, the screw-threaded connection to adjust the punch-stock, substantially as described.

2. The yoke D', stock C, hollow punch *c*, and screw-threaded connection for adjusting the punch-stock, as above claimed, in combination with the fixed die F, sliding sleeve F'', and punch E, substantially as and for the purposes described.

3. The revolving cam B<sup>3</sup>, head-stock I, having pin *i*, and arm I', in combination with the feed-carriage G, substantially as and for the purposes described.

4. The reciprocating arm I', in combination with the upper sliding jaw G' of the feed-carriage, when said jaw is actuated to clamp and release the iron bar by the intermediate devices through the reverse movement of the arm I', substantially in the manner described.

ISSACHAR W. DOEG.

Witnesses:

JONATHAN F. GARLAND,  
DANIEL W. MCNEAL.