

C. G. REED.
Scaffold.

No. 163,329.

Patented May 18, 1875.

Fig. 1.

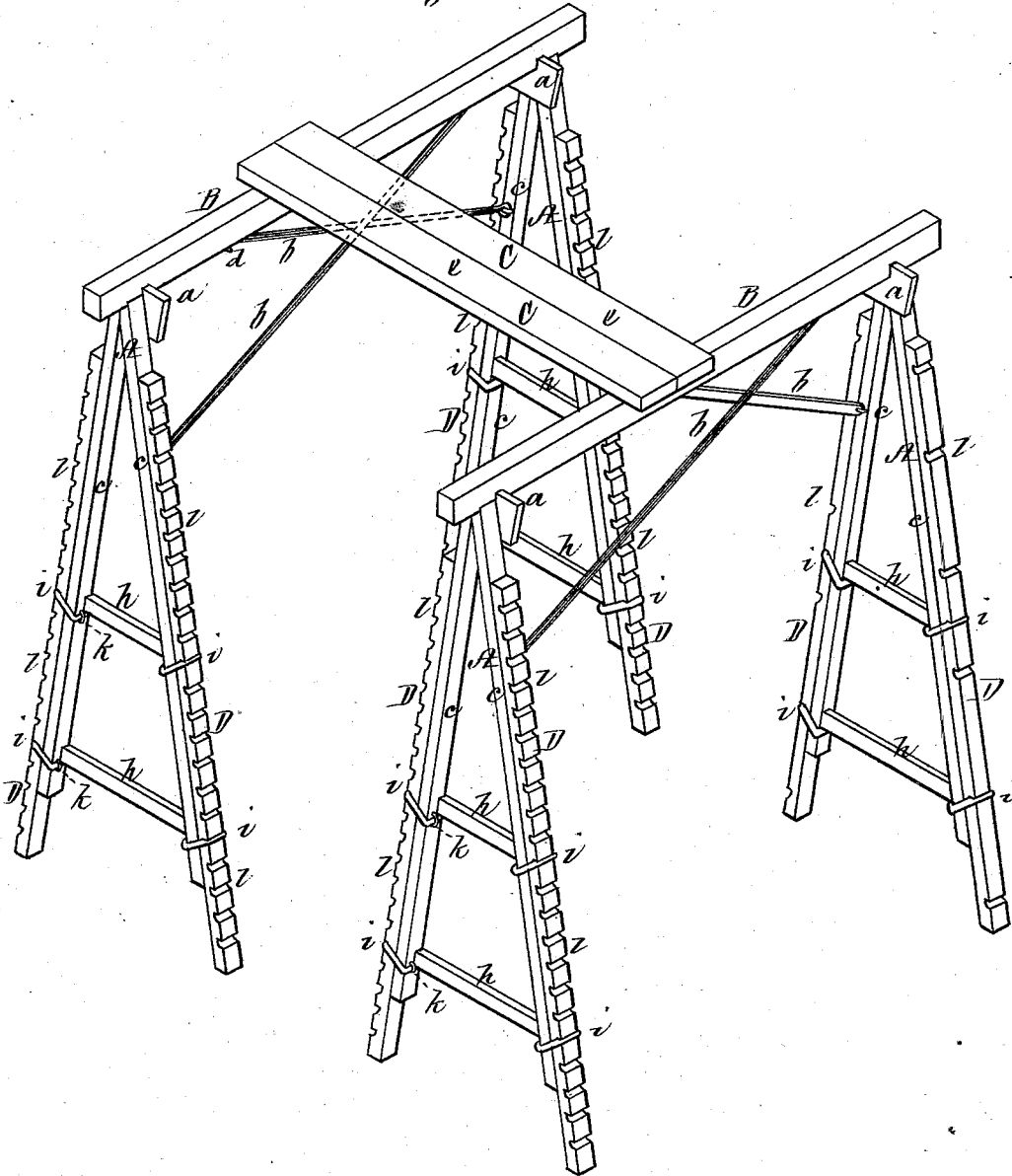

Witnesses,
W. J. Cambridge
Wm. Bonner et al

Inventor,
Clarence G. Reed
By Stearns & Stearns
Attorneys

C. G. REED.
Scaffold.

No. 163,329.

Patented May 18, 1875.

Fig. 2.

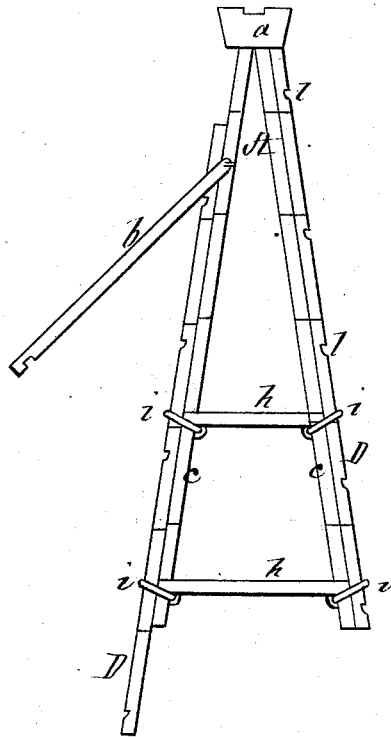

Witnesses,
W. J. Cambridge
M. J. Monenstein

Inventor,
Clarence G. Reed
By T. Schemacher & Stearns
Attorneys

UNITED STATES PATENT OFFICE.

CLARENCE G. REED, OF CAMBRIDGE, MASSACHUSETTS.

IMPROVEMENT IN SCAFFOLDS.

Specification forming part of Letters Patent No. 163,329, dated May 18, 1875; application filed April 9, 1875.

To all whom it may concern:

Be it known that I, CLARENCE G. REED, of Cambridge, in the county of Middlesex and State of Massachusetts, have invented certain Improvements in Staging or Scaffolding for the use of plasterers, fresco-painters, carpenters, &c., of which the following is a full, clear, and exact description, reference being had to the accompanying drawings making part of this specification, in which—

Figure 1 is a perspective view of a staging constructed in accordance with my invention. Fig. 2 is an elevation of one of the adjustable end frames or supports of the staging.

My invention has for its object to provide a convenient means by which the platform of a staging used by mechanics may be readily secured in various places at any desired height.

My invention consists in providing the top of each supporting-frame with a notched plate or cleat for preventing the lateral movement of the end of the cross-joist thereon.

To enable others skilled in the art to understand and use my invention, I will proceed to describe the manner in which I have carried it out.

In the said drawings, A A A A represent two pair of triangular frames, placed in a vertical position, the two frames of a pair being parallel to each other, and connected at their tops by a cross-joist, B, which rests thereon, and is prevented from being displaced in a lateral direction by notched strips or cleats *a*, one in each frame, the under side of the joist B having a notch formed near each end, whereby the tops of the frames are kept at the required distance from each other, the frames being held together by braces *b b*, secured to the side pieces *c* of each of the opposite frames A, and provided with hooks *d d*, which catch into rings or staples on the under side of the joist B, by which construction the two frames of a pair are rigidly held together in a vertical position. The platform C is formed by extending plank *e e* from one joist, B, to another, and as nothing projects above the surface of the platform the workmen can move about thereon without liability of tripping. The side pieces *c c* of each frame are connected by cross-bars *h h*, and immediately below each end of each bar is a clamp or band, *i*, the in-

ner end of which is secured to the side piece by a staple, *k*. Sliding upon the outer surface of each side piece, and passing inside its two clamps, *i i*, is a strip or leg, D, provided with a series of notches, *l l*, with which the outer ends of the clamps or bands engage.

When the platform is to be placed at a level above that of the perpendicular height of the side pieces *c*, it is simply necessary to slide or bring out the legs D before erecting the staging until the top of the frame is elevated to the proper height, when the weight of the side pieces and platform will cause the clamps or bands to draw down into the notches *l l* of the legs D, and thus prevent the side pieces from slipping down thereon.

Where the platform is not intended to support much weight the legs D need not be provided with notches *l l*, sufficient friction or adhesion of the surfaces of the strips and side pieces being insured by the binding of the clamps on the outer surface of the legs.

To facilitate the raising of the platform exactly to any determined height the side pieces *c* or legs D may be graduated to represent feet and portions thereof, by which means the desired adjustment may be made in a very convenient and expeditious manner. I prefer to attach the inner ends of the clamps to the side pieces at points immediately under the cross-bars *h h*, so that in the event of the strain being so great as to break or pull out the staple *k* the inner side of the clamp will be brought into contact with the under side of the cross-bar *h*, and thus prevent the slipping down of the side pieces.

The frames may be erected upon the staircase, or the uneven surface of a floor or the ground, by simply bringing the bottoms of the legs down to a firm bearing thereon, (see Fig. 2,) which may be readily done on account of the legs being constructed and operated independently of each other.

Instead of hooked braces for keeping the frames A A in a vertical position, the braces may, if desired, be notched at their outer ends, and rest on a nail driven into the side of the cross-joist B, and the frames may be of rectangular or other suitable form without departing from the spirit of my invention.

From the foregoing it will be seen that a

frame for staging constructed as above described is particularly useful to plasterers, painters, whiteners, carpenters, masons, and other mechanics, as it can be securely erected at various heights, and in any position or place, in a convenient and expeditious manner.

What I claim as my invention, and desire to secure by Letters Patent, as an improvement in scaffolding, is—

In combination with the frame A, the notched joist B and the notched cleat *a*, substantially as and for the purpose set forth.

Witness my hand this 5th day of April, A. D. 1875.

CLARENCE G. REED.

In presence of—

N. W. STEARNS,
W. J. CAMBRIDGE.