

A. ALEXANDER.  
Compound Steam-Engine.

No. 163,348.

Patented May 18, 1875.

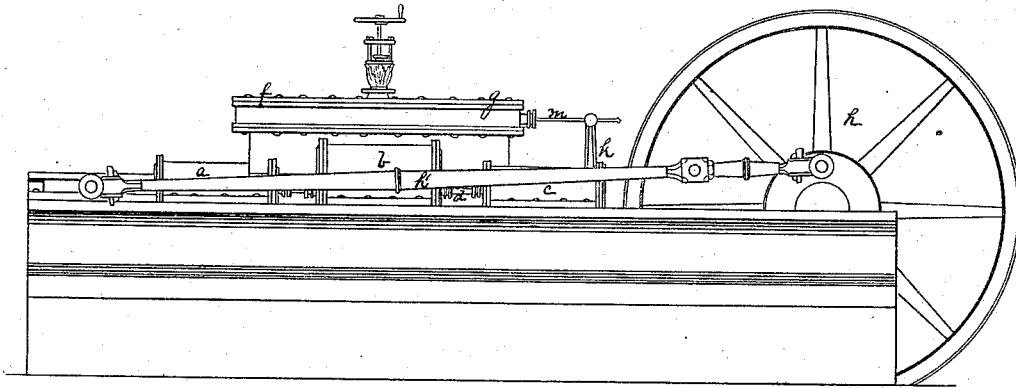

FIGURE 1.

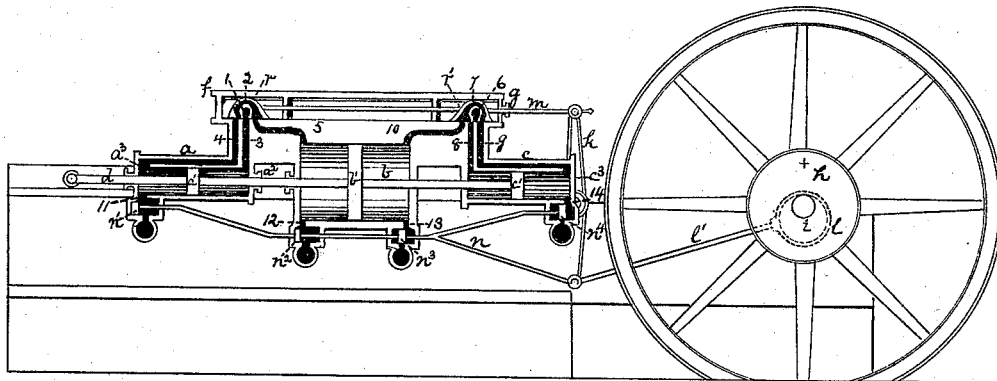

FIGURE 2.

WITNESSES

B. S. Ford  
James E. Kay

INVENTOR

Abram Alexander  
by his attys,  
Bakewell, Smith, & Ken

# UNITED STATES PATENT OFFICE.

ABRAM ALEXANDER, OF PITTSBURG, ASSIGNOR TO FARRELLY ALDEN, OF ALLEGHENY, PENNSYLVANIA.

## IMPROVEMENT IN COMPOUND STEAM-ENGINES.

Specification forming part of Letters Patent No. 163,348, dated May 18, 1875; application filed January 7, 1875.

*To all whom it may concern:*

Be it known that I, ABRAM ALEXANDER, of Pittsburg, in the county of Allegheny and State of Pennsylvania, have invented a new and useful Improvement in Compound Steam-Engines; and I do hereby declare the following to be a full, clear, and exact description thereof, reference being had to the accompanying drawing forming a part of this specification, in which—

Figure 1 is a side view of my improved steam-engine, and Fig. 2 is a vertical longitudinal section of the same.

My invention relates to that class of steam-engines in which, by the arrangement and operation of suitable valves and ports, a portion of the exhaust steam is admitted from the front side of the piston to its rear side, for the purpose of balancing the piston—that is, of equalizing the steam-pressure on both sides of the piston—so that on its return stroke it is not compelled to act upon and overcome the pressure of the exhaust steam, while the remainder of the exhaust steam is at the same time admitted from the first cylinder into a second cylinder, called a vacuum-cylinder, arranged at the end of the first cylinder, in the same axial line therewith, and provided with a piston, which is a continuation of the piston of the first cylinder, where it operates upon the piston therein, and drives it back. In this movement no resistance is encountered in the first cylinder, because the piston is perfectly balanced therein, while no resistance is encountered by the piston in the second cylinder. Then, the piston of the first cylinder being perfectly balanced, and there being no resistance to the movement of the piston in the second cylinder, the exhaust steam taken from the first cylinder, operating in the second cylinder, causes the reverse stroke of the piston in the first cylinder. The result of this is a very great gain of power. The vacuum-cylinder is made of greater diameter than the first cylinder, so that, when the exhaust steam is admitted therein, it at first operates against the piston at a pressure above that of the atmosphere; but this pressure is gradually reduced by the dilation of the steam as the pis-

ton recedes, until, at the end of the stroke, it is reduced to the pressure of the atmosphere.

My invention consists in the arrangement of a steam-cylinder at each end of the auxiliary cylinder, communicating therewith by means of suitable valves and ports. The steam-cylinders operate alternately, their pistons are balanced on their return strokes by the free circulation of the exhaust steam around them, and a continuous steady gain of power is effected by the operation of the piston of the auxiliary cylinder by the exhaust steam admitted alternately to opposite ends from the steam-cylinders.

By my improvement I gain all the advantages of a low-pressure engine, while I dispense with the expense of a condenser.

To enable others skilled in the art to make and use my invention, I will describe its construction and mode of operation.

I arrange in the same axial line a large vacuum or exhaust cylinder, *b*, and two steam-cylinders, *a* and *c*, and provide each with pistons *b'*, *a'*, and *c'*, having a stem, *d*, common to all. I also make two valve-boxes, *f* and *g*, in which are the steam-supply valves, and the valves between the cylinders *a* and *c* and the cylinder *b*. The piston *d* operates the wheel *h* by means of the pitman *h'*, and the eccentric *i* is connected with and operates the pivoted arm *k* by means of the yoke *l* and rod *l'*. Attached to one end of the arm *k* is a rod, *m*, which operates the valves in the boxes *f* and *g*, and to the other end a rod, *n*, which operates the escape-valves *n<sup>1</sup>*, *n<sup>2</sup>*, *n<sup>3</sup>*, and *n<sup>4</sup>*. In the valve-box *f* is a slide-valve, *r*, which operates across the steam-ports. In this valve is a steam-port, 1, and an exhaust-steam port, 2. The port 1 opens directly into the passage 3, and the port 2 opens into the passage 4 at one end, and at the other into the passages 3 and 5, which latter leads to the exhaust-cylinder *b*. In the valve-box *g* there is a similar slide-valve, *r'*, having a series of similar ports and passages, the steam-supply port being marked 6, the exhaust-steam port 7, the passage from the port 6 to the cylinder *c*, 8, the passage from the port 7 to the cylinder *c*, 9, and the passage from the port 7 to the cylinder *b*, 10. The cyl-

inder *a* is provided with an escape-port, 11, the cylinder *b* with two escape-ports, 12 and 13, and the cylinder *c* with an escape-port, 14.

The operation of this engine is as follows: Beginning with the cylinder *a*, steam is admitted through the port 1, and passes through the passage 3 into the cylinder *a*, where, operating between the cylinder-head *a*<sup>2</sup> and the piston *a*<sup>1</sup>, it forces the piston *a*<sup>1</sup> back to the opposite cylinder-head *a*<sup>3</sup>. At this point the valve *r*, operating by means of the arm *k* and rod *m*, closes the port 1, while it brings the port 2 across and in connection with the passages 3, 4, and 5. Then a portion of the exhaust steam from the cylinder *a* rushes through the port 2 into the passage 4, and thence into the cylinder *a* behind the piston *a*<sup>1</sup>. This brings the pressure of the exhaust steam on both sides of the piston and balances it, so that on its reverse movement it will encounter no resistance from an unequal pressure on its front side. The remainder of the exhaust steam passes through the port 2 into the passage 5, and thence into the cylinder *b* at the rear side of the piston *b*<sup>1</sup>. At this instant the reverse stroke of the piston takes place, being caused by the operation of the piston in the cylinder *c*. The operation in this cylinder is the same as that just described.

While the piston-stem is moving in a direction the reverse of that just described, the exhaust steam from the cylinder *a*, entering the cylinder *b* in the manner just described, operates against the piston *b*<sup>1</sup>, so as to force it onward to the other end of the cylinder *b*. When the exhaust steam enters the cylinder *b* the pressure is very much greater than the pressure of the atmosphere; but as the piston advances the pressure is gradually reduced by the dilation of the steam until the piston reaches the farthest limit of its stroke, at which point, the size of the cylinder being regulated in reference to the amount of exhaust steam admitted therein, the pressure has been reduced until it equals the pressure of the external atmosphere. Now, then, taking the cylinder *c*, which is situated at the opposite end of the cylinder *b*, the steam is admitted through the port 6 and the passage 8 into the cylinder *c*, and operates against the piston *c*<sup>1</sup>, forcing it onward to the cylinder-head *c*<sup>3</sup>, at the opposite end of the cylinder. Then, by the movement of the valve *r*<sup>1</sup>, the steam-supply is cut off, and the port 7 is brought in connection with the passages 8, 9, and 10. Then a portion of the exhaust steam from the cylinder *c* passes through the port 7 and the passage 9 to the rear side of the piston *c*<sup>1</sup>, and balances it in the manner described in reference to the piston *a*<sup>1</sup>. The remainder of the exhaust steam from the cylinder *c*, passing through the port 7 and passage 10, enters

the cylinder *b*, where it operates against the piston *b*<sup>1</sup>, to aid in the reverse movement of the piston, in the manner before described. While the piston-stem *d*, which carries all the pistons, is being moved forward in either of the cylinders *a* or *c*, the discharge-port in connection with such cylinder is opened, to permit the escape of the exhaust steam which had been admitted to the rear side of the piston, while the discharge-port of the opposite cylinder is closed, to prevent the escape of the exhaust steam as it enters back of the piston. Also, the discharge-ports on the opposite sides of the piston *b*<sup>1</sup> in the cylinder *b* are alternately opened and closed, for the purpose of preventing or permitting the escape of the exhaust steam from the cylinder *b*.

Thus it will be seen that I make use of a portion of the exhaust steam from the cylinders, for the purpose of balancing the pistons in the end cylinders *a* and *c*, while the remainder of the exhaust steam is admitted to the cylinder *b*, and utilized therein, for the purpose of aiding in the reverse stroke of the piston. This gain is constant, because, when the live steam is operating against the piston in one of the cylinders *a* or *c*, the exhaust steam from the other cylinder is operating in the same direction against the piston *b*<sup>1</sup>, while at the same time there is no resistance of the exhaust steam in the opposite cylinder *a* or *c*.

The size of the cylinder *b* should be regulated by the amount of the exhaust steam admitted from the cylinder *a* or *c*, so that when the piston *b* has reached the end of its stroke the steam which is admitted therein shall have been dilated or expanded until its pressure has been reduced to that of the atmosphere. If the size of the cylinder *b* is less than this, and does not afford sufficient space for the expansion of the steam to this extent, there is a loss of power equal to the difference between the pressure in the cylinder *b* and the pressure of the atmosphere.

What I claim as my invention, and desire to secure by Letters Patent, is—

The combination of the two steam-cylinders *a* and *c* with an auxiliary cylinder, *b*, each supplied with valves, ports, and pistons, having a common stem, *d*, the two steam-cylinders operating alternately, and alternately admitting their exhaust steam into the auxiliary cylinder *b*, to operate the piston therein, while their own pistons are balanced by the free circulation of the exhaust steam around them, substantially as described.

In testimony whereof I, the said ABRAM ALEXANDER, have hereunto set my hand.

ABRAM ALEXANDER.

Witnesses:

T. B. KERR,  
JAMES I. KAY.