

J. D. KUTZ.
Gas-Apparatus.

No. 163,385.

Patented May 18, 1875.

Fig. 1.

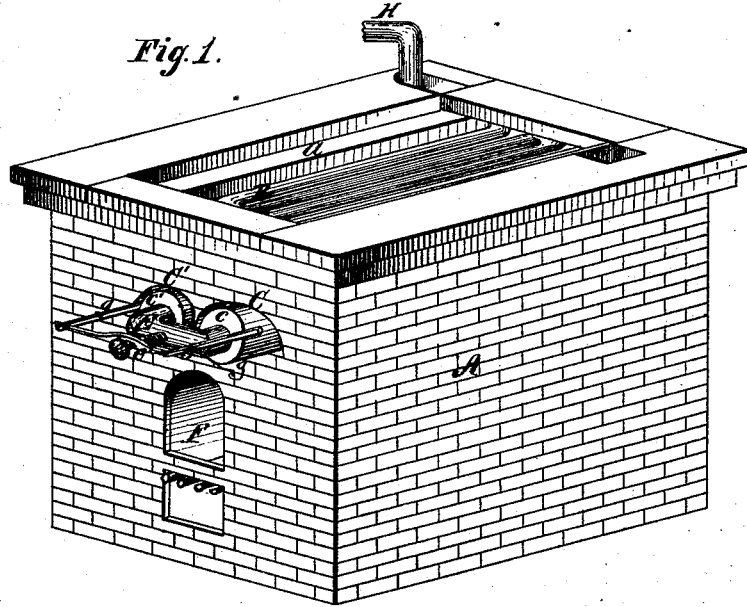
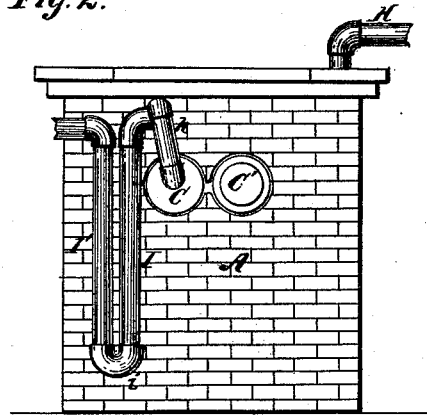

Fig. 2.



Witnesses.

Wm. F. Laws
Philip W. Hale,

Inventor.

John D. Kutz,
per Wm. Peale Hale,
Attorney.

J. D. KUTZ.
Gas-Apparatus.

No. 163,385.

Patented May 18, 1875.

x Fig. 3.

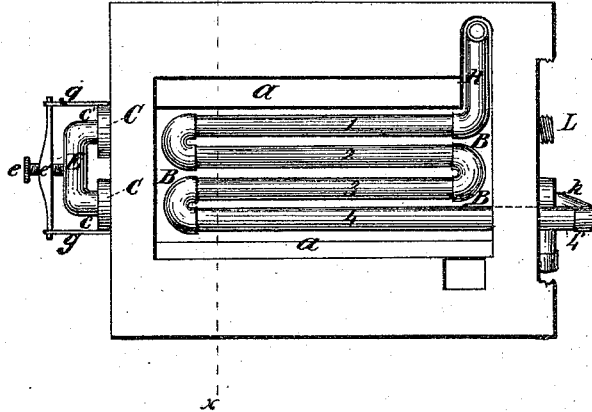

Fig. 4.

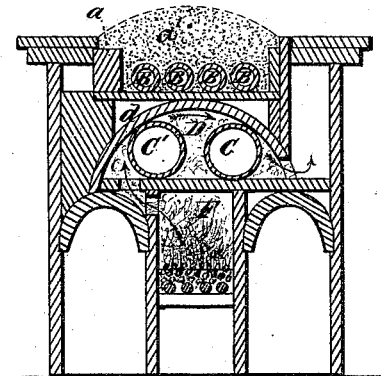
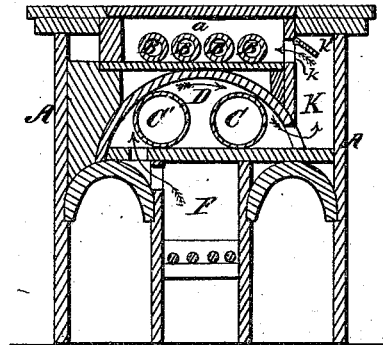

Fig. 5.



Witnesses.

Wm. F. Laws,
Philip W. Hale,

Inventor.

John D. Kutz,
per Wm. Peale Hale,
Attorney.

UNITED STATES PATENT OFFICE.

JOHN DANIEL KUTZ, OF SUNBURY, PENNSYLVANIA.

IMPROVEMENT IN GAS APPARATUS.

Specification forming part of Letters Patent No. 163,385, dated May 18, 1875; application filed April 20, 1875.

To all whom it may concern:

Be it known that I, JOHN D. KUTZ, of Sunbury, in the county of Northumberland and State of Pennsylvania, have invented certain new and useful Improvements in Gas-Machines; and I do hereby declare that the following is a full, clear, and exact description thereof, which will enable others skilled in the art to which it pertains to make and use the same, reference being had to the accompanying drawing, and to the letters of reference marked thereon, which form a part of this specification.

Figure 1 is an isometric perspective view. Fig. 2 is a rear-end elevation. Fig. 3 is a plan. Fig. 4 is a section taken on line *x x* in Fig. 3, and showing the vaporizing-pipes covered with sand. Fig. 5 is a section taken on line *x x* in Fig. 3, illustrating, in addition, a modification of my invention.

The object of my invention is the rapid manufacture of illuminating-gas from crude oil, naphtha, and the lighter products of petroleum, and the avoidance of the production of tar inside the retorts during the process of manufacture. It consists in certain novel arrangements of vaporizing-pipes and retorts, heat regulating, distributing, and equalizing devices, and a drip-seal, all of which will be hereinafter particularly explained, and pointed out in the appended claims.

In the drawings, A represents the brick-work surrounding the furnace and retorts, and partially inclosing the chamber *a*, upon the floor of which is arranged the vaporizer B. C C' are retorts arranged in an arched chamber, D, immediately over the furnace F, and separated therefrom by a tile floor, and directly under the vaporizer-chamber *a*, and separated therefrom by the arch *d* and tile floor of chamber *a*. The walls at the ends of the retort-chamber are closed around the retorts, which at each end project a short distance outside the brick-work. *c c'* are the removable heads of the retorts, and are connected by bent pipe E. These heads are retained in position by a clamp-screw, *e*, passing through bar *e'*, the ends of which project through eyes in arms *g g*, attached to the retorts. H is a bent pipe, which leads from an elevated tank containing the material to be converted into gas, and connects with

the first pipe 1 of the vaporizer. The last pipe 4 of the vaporizer projects through the brick-work, as shown at 4', and connects by a bent pipe, *h*, with retort C. To the under side of the projecting portion 4' a vertical pipe, I, is connected by a band or double elbow, *i*, and extends downward to near the foot of the brick-work, where it connects by a return-bend, *i*, with another pipe, I', which extends upward not quite to the top of pipe I, and is then bent outward. This bent portion is intended to lead to a receptacle for heavy residual oil, which passes through the vaporizer without being converted into vapor. The pipes I I' and return-bend *i* form the drip-seal. In the section shown in Fig. 4, *a'* represents sand, with which the vaporizer-chamber *a* is filled, and the pipes 1 2 3 4 surrounded. One purpose of this sand is to afford a ready and efficient means of regulating the degree of heat applied to the vaporizer. For instance, if an oil is to be converted which vaporizes at a very low temperature, only a light covering of sand is thrown upon the vaporizer; but if it is proposed to convert an oil requiring a great degree of heat to vaporize it, the sand is banked up to a height which will retain a sufficient amount of the furnace heat for the purpose. By increasing or diminishing the thickness of the sand at any time during the process of gas-making, it is obvious that the temperature of the vaporizer may be regulated as desired. Another purpose of the sand is to cause an even distribution of the furnace heat over all portions of the vaporizer.

In the modification shown in Fig. 5, the sand is omitted, and the top of the chamber *a* closed; said chamber communicating with flue-chamber K by one or more openings, *k*, which are provided with dampers *k'*, operated by any suitable means. If the vaporizer becomes too highly heated, the dampers may be opened to allow a portion of the heat to pass off. I regard the sand, however, as the most efficient means of controlling the temperature of the vaporizer.

The operation of my improvement during the process of making gas is as follows: The drip-seal is first sealed by filling the pipes I I' with water sufficient to close the passage through the return-bend *i*. This will prevent

the vapor from escaping. The retorts and vaporizer having been heated to the proper degree, which will be regulated according to the nature of the material to be converted into gas, as will be understood by those familiar with the manufacture of gas from liquid hydrocarbons, the liquid is turned on from an elevated tank, and flows through pipe H to the vaporizer. As it courses through pipes 1 2 3 4 of vaporizer B, it is converted into vapor, with the exception of a small portion of heavy residuum which flows along the bottoms of the pipes, and runs into the drip-seal, while the vapor passes through pipe *h* into and through retort C, and through pipe E, which connects the heads of the retorts to retort C', being converted in its passage through the highly-heated retorts into a fixed gas, which passes from the last retort to a hydraulic main, or other purifier, which may be connected with said retort by a screw-tap, L, or in any other suitable manner.

Should the heavy residuum, before referred to, be permitted to flow into the retorts, it would there, by the great heat, be converted into tar, and retard the conversion of the vapor to a fixed gas, and, besides, soon clog up the retorts and render them useless until cleaned, thus involving delay and expense.

By locating the entrance to the drip-seal in the path of this residuum before it can reach the pipe *h*, I effectually prevent it from entering the retorts.

Having now fully described the construction and operation of my improvement, I claim and desire to secure by Letters Patent—

1. In combination with the furnace of a gas apparatus, the heating-chamber *a*, containing the vaporizing-tubes B, and a body of sand surrounding said tubes, whereby the heat is equally distributed, and is regulated in degree, substantially as and for the purpose set forth.

—2. The combination of open heating-chamber *a*, containing sand - covered vaporizer B, retorts C C' arranged below said vaporizer, and connected therewith by pipe *h*, and a drip-seal connected to the under side of projecting portion 4' of outlet-pipe 4 of the vaporizer, as shown and described.

In testimony that I claim the foregoing as my own invention I affix hereto my signature in presence of two witnesses.

JOHN DANIEL KUTZ.

Witnesses:

J. F. DAVIS,
JAMES ELDEN.