

G. S. LONG.
Machine for Cutting Cork.

No. 163,387.

Patented May 18, 1875.

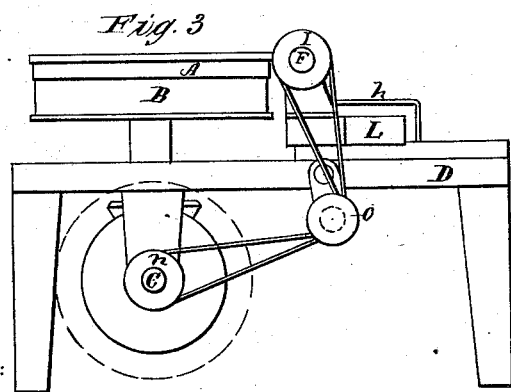
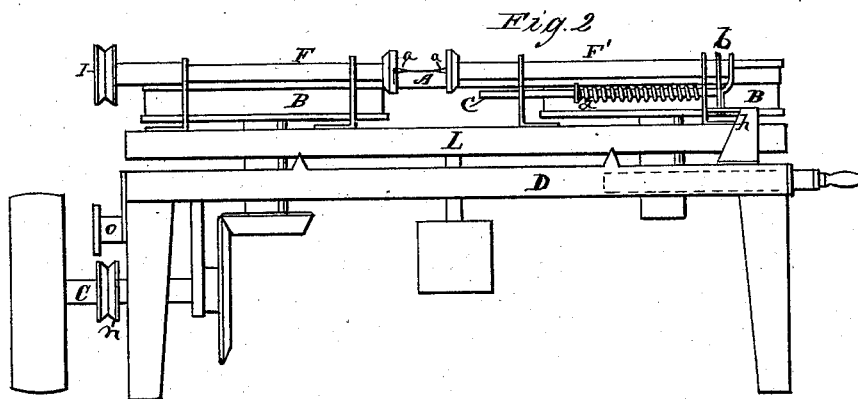
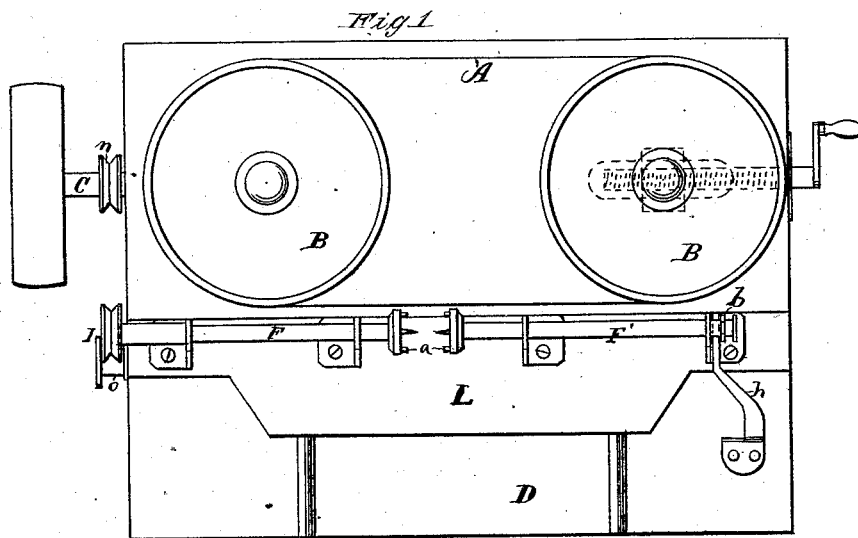

Witnesses:

Henry A. Mitchell
Geo. H. Gowdy

Inventor:

George Samuel Long
By James Shepard atty.

UNITED STATES PATENT OFFICE.

GEORGE S. LONG, OF FORESTVILLE, CONNECTICUT, ASSIGNOR OF TWO-THIRDS HIS RIGHT TO BURTON ALLEN, 2D, NORMAN ALLEN, AND HENRY W. PORTER, OF SAME PLACE.

IMPROVEMENT IN MACHINES FOR CUTTING CORKS.

Specification forming part of Letters Patent No. 163,387, dated May 18, 1875; application filed September 8, 1874.

To all whom it may concern:

Be it known that I, GEORGE SAMUEL LONG, of Forestville, in the county of Hartford and State of Connecticut, have invented certain new and useful Improvements in Machines for Cutting Corks, of which the following is a specification:

My invention consists, first, in the employment of endless smooth-edge knife, running over suitable pulleys, for cutting cork, rubber, &c., and also in the combination and arrangement of devices, as hereinafter described.

In the accompanying drawings, Figure 1 is a plan view of a machine which embodies my invention. Fig. 2 is a front elevation of the same, and Fig. 3 is a side elevation of the same.

A represents a thin steel knife, the upper edge of which is sharp and smooth. This knife is brazed together, or otherwise connected so as to make it endless, and is supported upon two pulleys, B B, which pulleys should be made so that the distance between them can be made more or less, as occasion requires, in order that knives of varying lengths may be drawn taut upon said pulleys. F F' designate spindles, one of which is provided with driving-pulley I, and at their inner ends they are provided with points or clutches *a a*. These spindles are arranged upon a movable carriage, L, which moves upon the bed D. to and from the edges of the pulleys B B. The spindle F' is arranged to move longitudinally in its bearings, and is connected to a shipper, *b*, one end of which shipper is bifurcated, and rests in a groove near one end of the spindle, after the usual manner of constructing shippers. The lower end of the shipper *b* is secured to a sliding rod, *c*, provided with spring *d*; which spring has a tendency to keep the spindle F' thrown to the left, or toward the spindle F. To the bed D I secure a cam, *h*, and the lower end of the shipper *b* extends downward, so as to engage with said cam. As the carriage L is drawn back from the knife A and pulleys B B, the cam *h* acts upon the shipper, and throws the clutches *a a* apart. The driving-shaft C, Fig. 3, is connected by means of bevel-gear to the pulley

B, and is also provided with a small pulley, *n*, for the purpose of communicating motion, by means of a belt, to the pulley I. I prefer to arrange this belt to run over the adjustable pulley *o*, as shown in Fig. 3. It will be seen that by this arrangement, when the carriage is drawn backward, the belt is slackened; but when the carriage is forced up toward the knife, the belt becomes taut, and communicates motion to the spindle F.

In order to cut cork-wood into bottle-corks by my machine, the wood is first blanked out in square or other shaped blocks. The carriage L is drawn back, so as to open the clutches *a a*, and a block is placed between said clutches. The carriage is then forced forward, and as the lower end of the shipper *b* slides off the cam *h*, the spring *d* throws the clutches together, so as to engage with and hold the block. As the carriage approaches the knife A, the belt on pulleys *n* I becomes taut, and (the main shaft being in motion) the spindles F F' are made to revolve. The carriage is caused to stop at a given point, which is determined by means of a stop. (Not shown.) About the same time that the carriage stops, or a little before, the blank or block comes in contact with the rapidly-moving knife A, and so soon after the stopping of the carriage as the spindles F F' and the block make one revolution, the block is shaved off by the knife A, so as to leave it smooth and round. Withdrawing the carriage releases the cork, when a new blank or block can be inserted, and the operation repeated.

It is evident that this device may be used for cutting many substances and articles other than cork. The knife can be kept sharp by means of a suitable sharpener, so placed as to act upon the knife-edge as it passes by said sharpener.

As shown in the drawing, the spindles F F' and the knife A are parallel, and therefore they will cut only straight corks. In order to cut tapering corks it is only necessary to arrange the line of the knife at an angle to the line of the spindles, and in order to cut corks of varying tapers the carriage L may be ar-

ranged so as to be secured upon the bed at varying angles to the knife. I am aware of the patent granted to V. H. Buschman, May 15, 1866, No. 54,681, and hereby disclaim the same.

I claim as my invention—

1. The endless knife A, provided with a continuous sharp cutting-edge, and running over pulleys B B, substantially as and for the purposes set forth.

2. The combination of the endless knife A, pulleys B B, spindles F F', shipper *b*, cam *h*, and carriage L, substantially as described, and for the purpose set forth.

GEORGE SAMUEL LONG.

Witnesses:

NORMAN ALLEN,
GILES G. BUNNELL.