

**W. W. BALDWIN.
Magazine-Stove.**

No. 163,442.

Patented May 18, 1875.

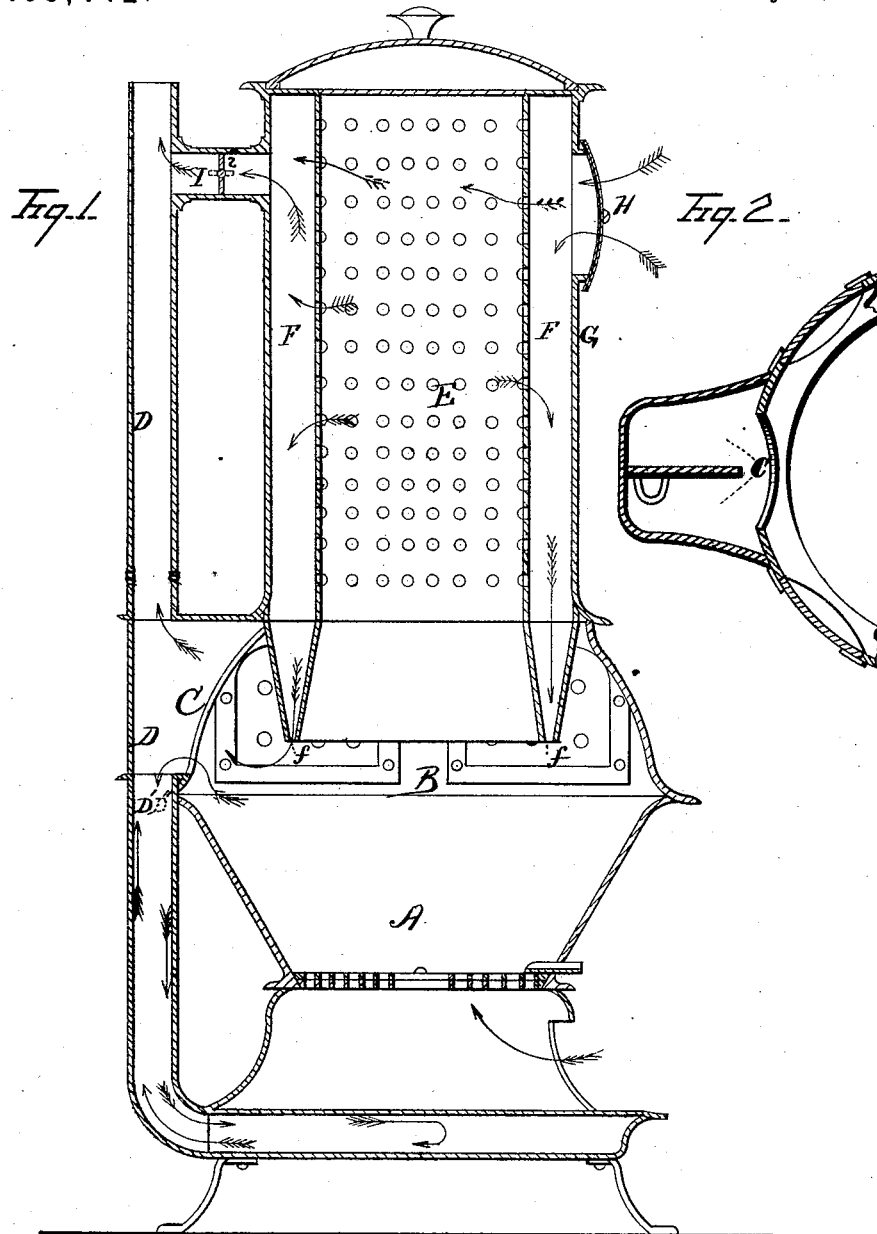

Witnesses

Walter Miller
Wm. W. Leggett

Inventor

William W. Baldwin.
By Leggett & Leggett,
Attorneys

UNITED STATES PATENT OFFICE.

WILLIAM W. BALDWIN, OF CLEVELAND, OHIO.

IMPROVEMENT IN MAGAZINE-STOVES.

Specification forming part of Letters Patent No. 163,442, dated May 18, 1875; application filed March 6, 1875.

To all whom it may concern:

Be it known that I, WILLIAM W. BALDWIN, of Cleveland, in the county of Cuyahoga and State of Ohio, have invented certain new and useful Improvements in Stoves; and I do hereby declare the following to be a full, clear, and exact description of the invention, such as will enable others skilled in the art to which it pertains to make and use it, reference being had to the accompanying drawings, which form part of this specification.

My invention relates to an improvement in stoves designed for heating apartments, and is so fully described in the following description and claims that no preliminary recital is needed.

In the drawings, Figure 1 is a longitudinal vertical section of a stove embodying my improvements. Fig. 2 is a detached view, showing, in plan section, the opening C at the base of the exit-flue.

A is the fire-pot; B, the combustion-chamber; C, the exit-flue, leading to the smoke-flue. D is the smoke-flue. It may or may not be provided with divisions D' D'', whereby the products of combustion may be made to descend, circulate about the ash-pit, and ascend into the smoke-flue D, which, however, forms no part of my invention. E is the fuel-reservoir. It is provided with perforations or slots *e*. F is an air-space left between the perforated wall of the reservoir and the outer wall G of the drum-section of the stove. H is a register, for admitting external air. I is a flue, leading from the air-chamber F into the smoke-flue D. *i* is a damper. *f* is a diminished orifice, through which the gases that may collect in the chamber F are discharged into the combustion-chamber B.

The operation of the device is as follows: Fuel contained in the fuel-reservoir E will, when the stove is well heated, emit gases, which said gases will escape into the room and become obnoxious, unless means are provided for their escape or consumption. This is effected by permitting them to escape into the chamber F, thence carried by the draft downward through the diminished orifices *f*,

where they are consumed in the combustion-chamber; and to assist this consumption, and at the same time furnish more oxygen to the flame in the combustion-chamber, a register, H, is provided, whereby external air can be admitted. When it is desired to diminish the heat of the stove, and for that purpose quell the combustion in the combustion-chamber B, the damper *i* in the flue I is opened, and the gases in the chamber F permitted to escape directly into the smoke-flue D, instead of permitting them to descend into the combustion-chamber B.

It will be noticed that the outer wall G of the drum-section of the stove forms the outer wall of the air-chamber F, and this outer wall or drum is dropped down into the combustion-chamber, so as, by its continuation, to diminish the air-space F, and form a contracted opening, *f*, at the bottom.

I am not aware that a stove provided with such a perforated reservoir and air-space, F, has ever before been provided with a flue, I, and with or without a damper, *i*; and I am not aware that a stove of this description has ever before been made with a fuel-reservoir, and a smoke-flue, D, leading therefrom, the opening C into the said flue extending below the base of the said fuel-reservoir, whereby the smoke-flue within the limits of the stove is made to form a portion of the combustion-chamber.

What I claim is—

1. The combination, with the reservoir E and opening *f*, of the opening C, made to extend below the lower end of the wall G, substantially as and for the purpose described.
2. The combination, with the perforated reservoir E, the perforations of which communicate directly with the air-space F, and the air-space F, of the flue I and damper *i*, substantially as and for the purpose described.
3. The combination, with the perforated reservoir E, the perforations of which connect directly with the air-space F, of air-space F, flue I, and air-register H, substantially as and for the purpose described.
4. The combination, with the combustion

chamber B, perforated reservoir E, the perforations of which communicate directly with the air-space F, and air-space F, of the exit-flue C and flue I, substantially as and for the purpose described.

5. The combination, with the combustion-chamber B, air-space F, and flues C and I, of the air-register H, by which means the draft has direct transit through the reservoir E with-

out passing down by an indirect course, substantially as and for the purpose described.

In testimony whereof I have signed my name to this specification in the presence of two subscribing witnesses.

WILLIAM W. BALDWIN.

Witnesses:

E. W. ANDREWS, Jr.,

L. S. FISH.