

I. BARROWS.
Milk-Cooler.

No. 163,443.

Patented May 18, 1875.

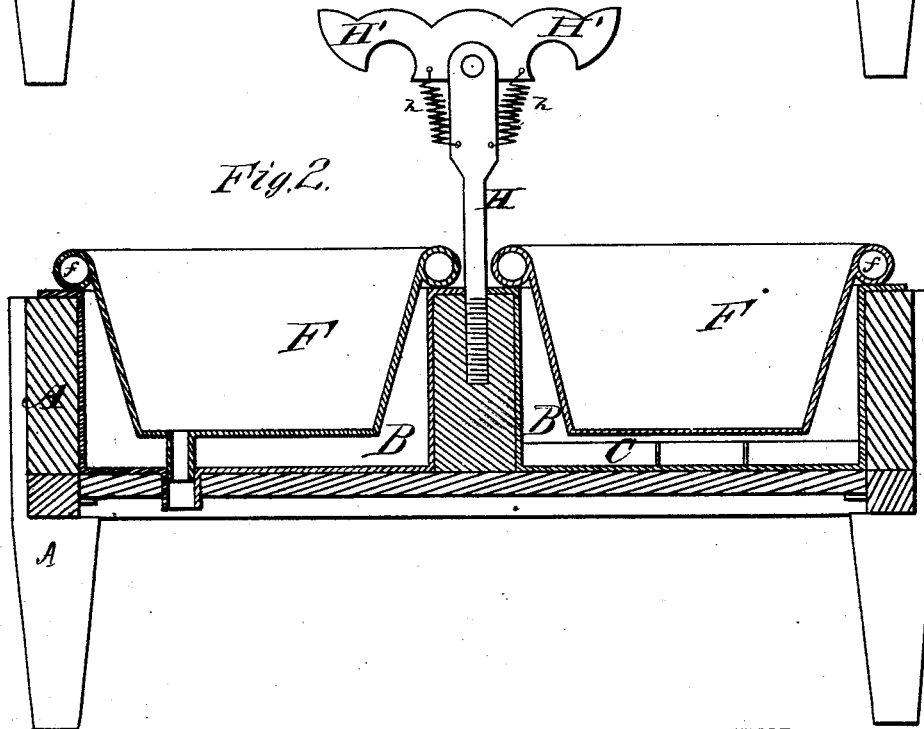
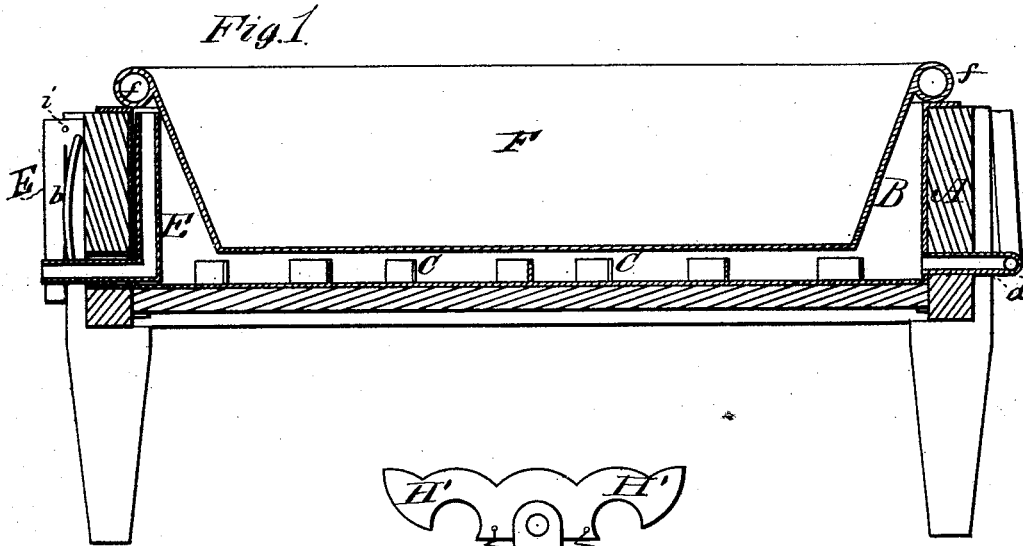

WITNESSES

S. J. Hayes
F. S. Evans

INVENTOR

Ira Barrows

By J. C. Sattrop

Attorneys

I. BARROWS..
Milk-Cooler.

No. 163,443.

Patented May 18, 1875.

Fig. 3.

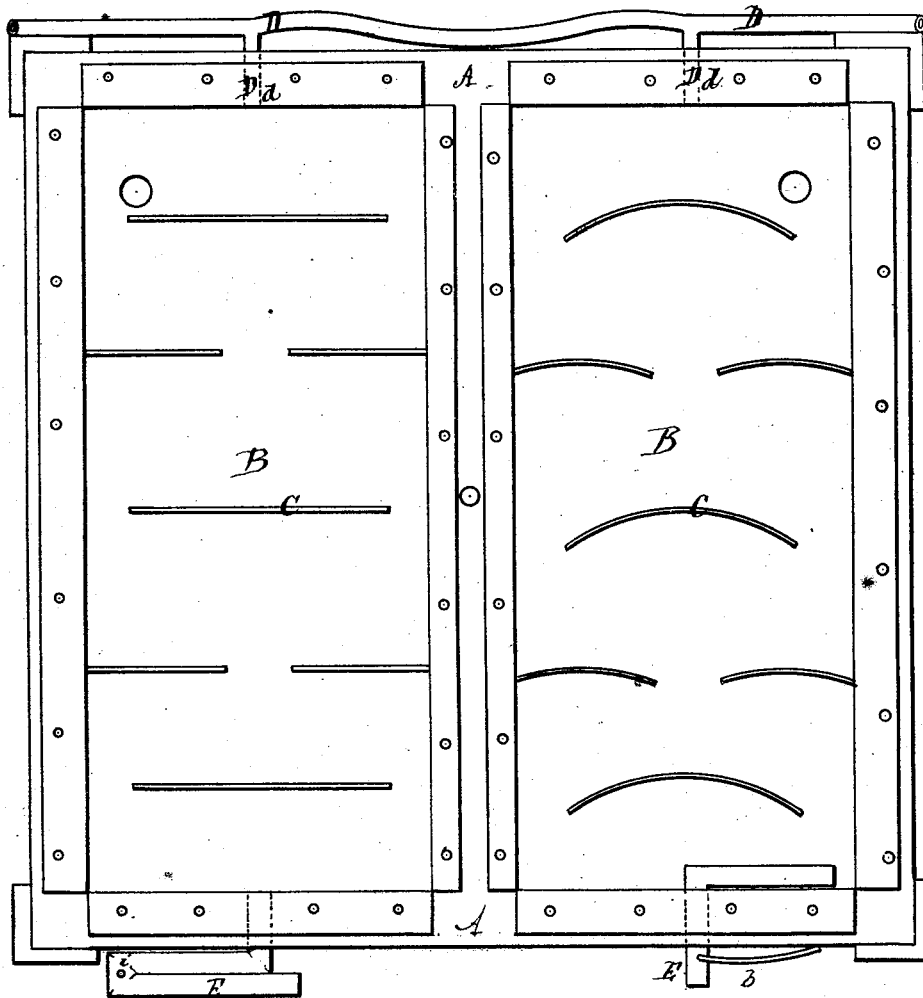

WITNESSES

S. J. Hayes
H. S. Crund.

INVENTOR

Ira Barrows

By J. L. Sattinof Attorneys

I. BARROWS.
Milk-Cooler.

No. 163,443.

Patented May 18, 1875.

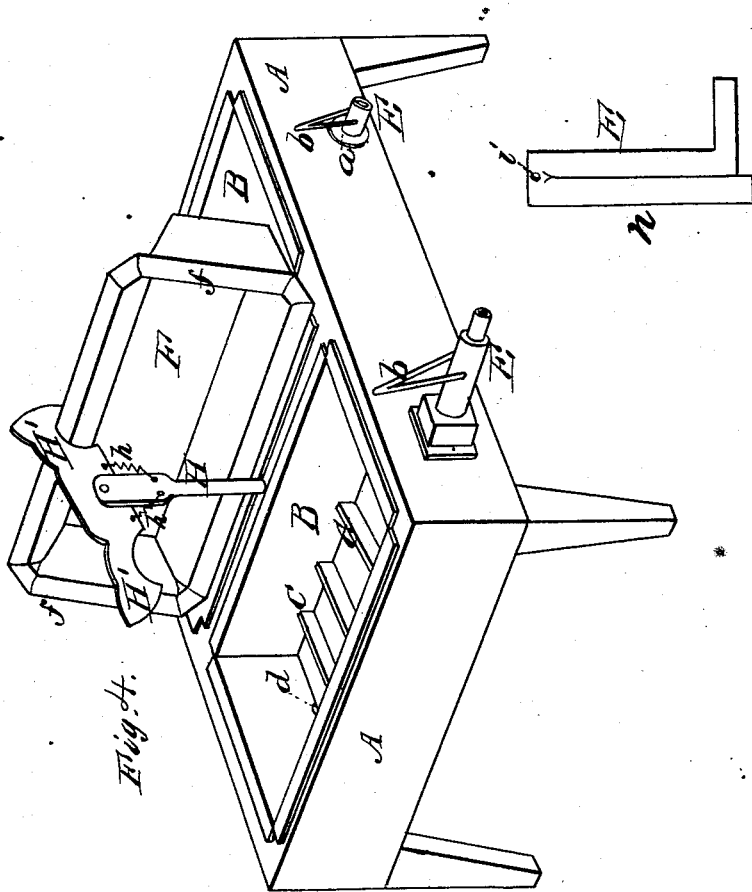

Fig. 4.

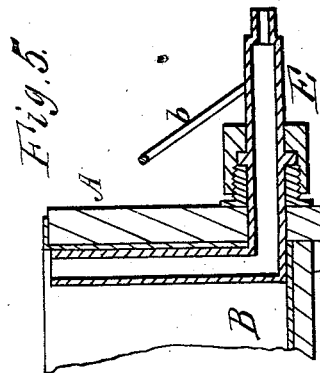

Fig. 5.

WITNESSES
E. H. Bates
W. D. Dow

INVENTOR
Ira Barrows
H. Lathrop ATTORNEY

UNITED STATES PATENT OFFICE.

IRA BARROWS, OF GOUVERNEUR, NEW YORK.

IMPROVEMENT IN MILK-COOLERS.

Specification forming part of Letters Patent No. **163,443**, dated May 18, 1875; application filed August 7, 1874.

To all whom it may concern:

Be it known that I, IRA BARROWS, of Gouverneur, in the county of St. Lawrence and State of New York, have invented certain new and useful Improvements in Milk-Coolers; and I do hereby declare the following to be a full, clear, and exact description thereof, reference being had to the accompanying drawings and to the letters of reference marked thereon.

The nature of my invention consists in the construction and arrangement of a milk-cooler, as will be hereinafter more fully set forth.

In the annexed drawing, forming part of this specification, Figure 1 is a representation of a vertical sectional view. Fig. 2 represents a cross-section. Fig. 3 shows a top or plan view. Fig. 4 represents a perspective view of my invention. Fig. 5 shows a detail view of same.

A represents a frame, of any suitable size and shape, to contain two or more cooling-vats or coolers, B B, of any ordinary form and dimensions. On the bottom of each cooler B are secured slats C C, which may be curved or straight, as desired, and placed alternately in such a manner as will best retard the flow of the water from the inlet to the outlet. The water is admitted into the coolers through suitable branch pipes *d d* from a common water-pipe, D. F F represent the milk-pans placed in the coolers B, and provided with a bead or flange, *f*, around the upper edges to rest upon the upper surface of the frame. Suitable packing may be introduced to render the space between each cooler and its milk-pan air-tight. At the opposite end of each cooler from the inlet-pipe *d* is the outlet-pipe E, made in the form of an elbow, one, usually the short, arm passing through a suitable stuffing-box, *a*, arranged in or through the side of the frame and the cooler at or near the bottom thereof, and the other, usually the long arm, may be inside or outside of the pan. When the longer arm is inside of the pan the end of the other arm of the pipe, outside of the frame, is attached a pointer, *b*, parallel with the inner arm of the

L-shaped outlet-pipe. The pipe E may be turned in the box *a*, so as to bring the end of its longer arm at any desired height from the bottom of the cooler, or, in other words, adjusting the height of the outlet, as required, thereby regulating the height of the water in the cooler. The pointer *b* on the outside forms a lever for operating the pipe, and at the same time indicates the height of the inner end of the outlet-pipe. This pipe takes the water from the top.

In coolers where there would not be space enough for the inner end of the pipe E to operate, I place the long arm of E on the outside of the pan. It may have a double elbow, *n*, on the outside, which will operate in precisely the same manner, but takes the water from the bottom. When constructed with a return-elbow on the outlet-pipe E it has a small air-hole or vent, *i*, in the double elbow, through which a current of air flows inward while the water runs through the pipe, thereby preventing said pipe from becoming a siphon and draw out all the water in the cooler. In the frame A, between the two coolers, is fastened a standard, H, at the upper end of which are pivoted two hooks, H' H', held downward by means of springs *h h*.

When it is necessary to clean or air the coolers the pans F are raised from the outside inward until the hooks H' catch on the beads on the outer sides of the pans and hold them in this position.

Having thus fully described my invention, what I claim as new, and desire to secure by Letters Patent, is—

1. In a milk-cooler, the adjustable L-shaped outlet-pipe E to regulate the height of the water in the cooler, substantially as herein set forth.

2. In a milk-cooler, the combination of the outlet adjustable pipe E and the elbow *n* on the outside of the cooler, having air-hole or vent *i*, substantially as and for the purposes herein set forth.

3. In combination with the frame A, coolers B B, and beaded pans F F, the standard H with hooks H' H' and springs *h h*, sub-

stantially as and for the purposes herein set forth.

4. The combination of the adjustable L-shaped outlet-pipe E and the pointer *b*, as described, for regulating and maintaining the height of the fluid in the pans, substantially as and for the purposes herein set forth.

In testimony that I claim the above I have hereunto subscribed my name in the presence of two witnesses.

IRA BARROWS.

Witnesses:

W. H. FOSTER,
H. CLAY SMITH.