

L. GODDU.

Machine for Nailing Shoe-Soles from Nail-Strips.  
No. 163,474.

Patented May 18, 1875.

FIG I

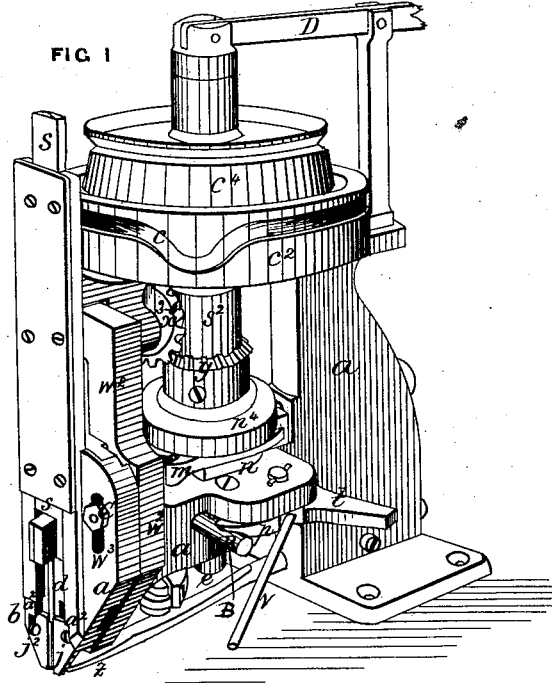
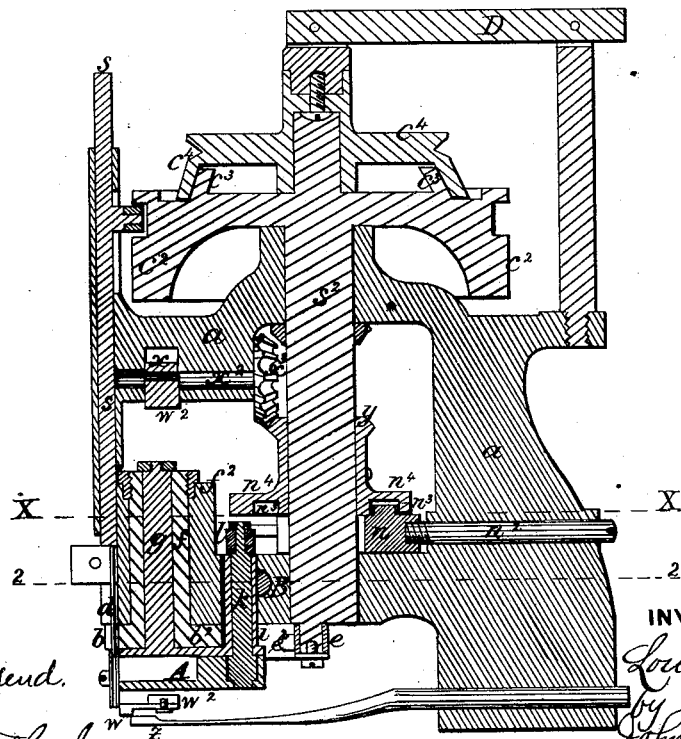

FIG II



WITNESSES

F. B. Townsend.

*A. C. Fisher*

INVENTOR

Louis Goddu

*J. Johnson and Johnson*  
his Attorneys.

Machine for Nailing Shoe-Soles from Nail-Strips.

No. 163,474

Patented May 18, 1875.

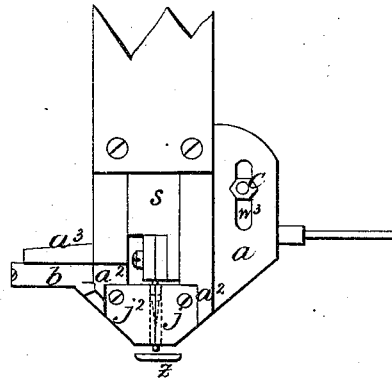
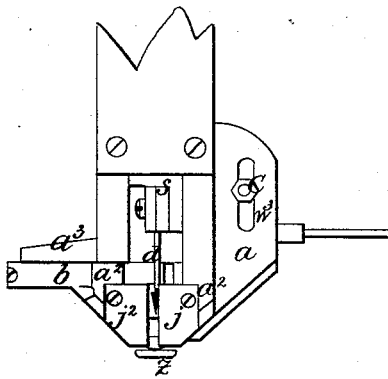

FIG V

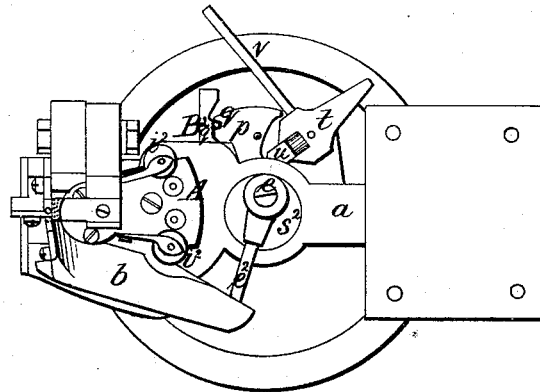
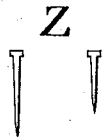

FIG VII

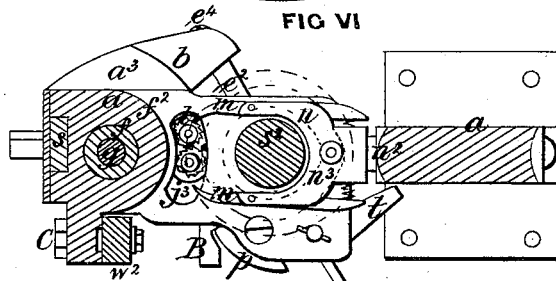
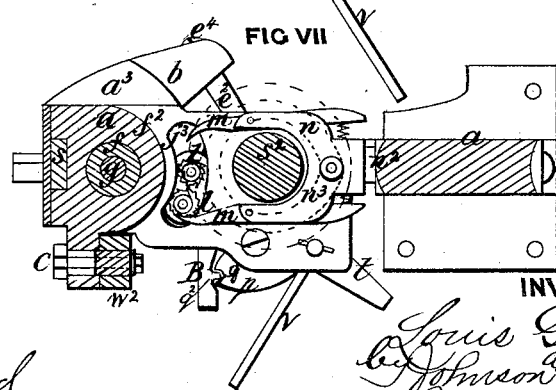

FIG IX



WITNESSES

*F. B. Townsend.*  
*J. H. Ruskensford*

INVENTOR

*Louis Goddu*  
*by Johnson and Johnson*  
*his Attorneys.*

L. GODDU.

Machine for Nailing Shoe-Soles from Nail-Strips.

No. 163,474.

Patented May 18, 1875.

FIG VIII

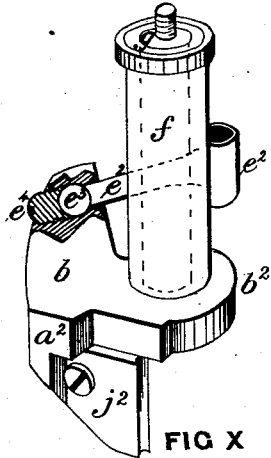

FIG IX

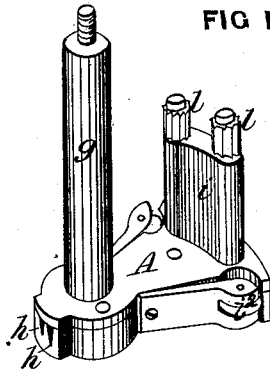

FIG X

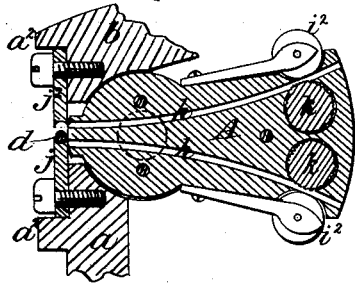

FIG XI

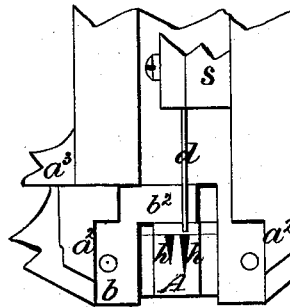
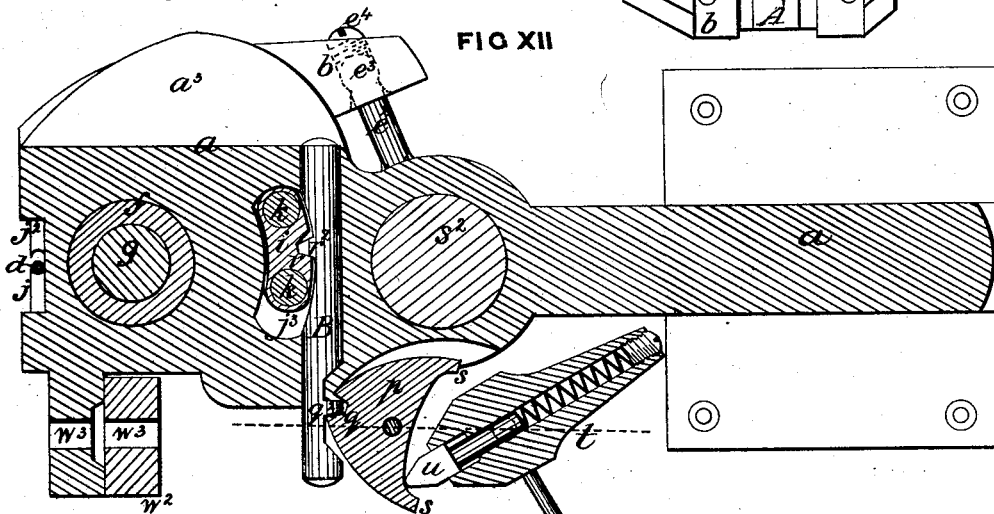

FIG XII



WITNESSES

*F. B. Townsend*  
*H. Rutherford*

INVENTOR

*Louis Goddu*  
 by *Johnson and Johnson*  
 his Attorneys.

# UNITED STATES PATENT OFFICE.

LOUIS GODDU, OF WINCHESTER, ASSIGNOR TO AMERICAN CABLE-SCREW-WIRE COMPANY, OF BOSTON, MASSACHUSETTS.

## IMPROVEMENT IN MACHINES FOR NAILING SHOE-SOLES FROM NAIL-STRIPS,

Specification forming part of Letters Patent No. **163,474**, dated May 18, 1875; application filed April 20, 1875.

### CASE A.

*To all whom it may concern:*

Be it known that I, LOUIS GODDU, of Winchester, in the county of Middlesex and State of Massachusetts, have invented certain new and useful Improvements in Machines for Nailing Shoe-Soles from Nail-Strips; and I do hereby declare that the following is a full, clear, and exact description thereof, which will enable others skilled in the art to which it pertains to make and use the same, reference being had to the accompanying drawings, and to the letters of reference marked thereon, which form a part of this specification.

The invention herein relates to machines for nailing boots and shoes with nails cut from a strip fed by such machine, and driven into the stock. In such operation the work is supported upon a jack or horn of suitable construction.

In this construction of machines I have made several important, valuable, and distinctive inventions, the chief design of which is to produce a practically-working machine for nailing boots and shoes with nails cut from metallic strips, as it is well known that there is no machine of this kind in use, in which metallic nails are supplied by the machine from a strip, in a manner to render the machine practically successful, and compete with the ordinary nailing-machines, in which the nails are cut and supplied from a wire. It has also been attempted in such machine to change the supply of nails of one length for others of a different length from nail-strips during the operation of nailing the shoe, as patented to Parker Wells, of date December 18, 1860. Such machine, although proposing such feature of invention, has never been put upon the market, and, among others, for the reason that it was practically a failure.

In the organization of my machine the feeding of metallic strips of different widths is not only simple, but in the highest degree practical, as the change from wide to a narrow strip, or vice versa, can be made at the will of the operator, not only without regard to the speed, but of the operation, of the machine, and without liability to the least derangement of the working mechanism or any part there-

of. This achievement is one of the things upon which the practical utility of such a machine is based, and is accomplished by what I denominate an automatic accommodating shifting device for the nail-strip carrier, in order that the change from one width to another may be made without regard to the fact as to whether the nail which is at the moment being fed is cut or not, or whether the change of the strip can be made or not, the means for effecting such change having been already made by the operator, and only awaits the severing of the nail already fed between the jaws to actually shift the strip-carrier. This is absolutely necessary, on account of the great speed of the machine, and without the means for accomplishing the thing stated it would be impossible to change the strips between the time of cutting and feeding, for the strip being fed directly across the face of the knife previous to the severing of the nail it will be seen that such nail must be cut before one of a different length can be fed into place. Were this not the case, the strip-carrier could not be changed, because there would be practically and constantly a strip between the jaws, and prevent any change in the position of the strip-carrier.

Another very important feature of my invention consists in the combination, in such a machine, of cutting-jaws, the operation of which, in connection with the strip-carrier and the driver, serves, first, to sever nail; second, compressing the nail to form the head; third, to form the guide-tube for the nail while being driven; and, finally, to form the nose, against which the stock is pressed while being supported by the anvil or jack.

The construction and combination of the elements by which these things are done constitutes a very advantageous feature in a machine in which the nails are cut and supplied from a metallic strip, and especially the formation of the head of the nail by the same movement which severs the nail, and within the grooved guide, through which it is driven, is wholly new to me, and of vital importance in a nail-strip-fed peg. Moreover, the cutting and forming of the nail and its head is made

under a great compressing-force of the jaws, and perfectly filling the nail-tube, which is formed by the jaws, and, as the diameter of the driver is necessarily the same size as such tube, it is obvious that the nail cannot be started downward without breaking the driver, unless there is a slight reaction of the jaw or jaws just before the driver strikes the nail, in order to relieve the intense pressure on the nail caused by forming its head, and to make the driving of it through the tube into the leather practical.

In the accompanying drawings, Figure 1 represents a view in perspective of a sole-nailing machine embracing my invention; Fig. 2, a vertical longitudinal section of the same; Fig. 3, an elevation of the nail severing and forming jaws, in the position they occupy to receive the blank; Fig. 4, a similar view, the jaws being shown as closed to sever and form the nail from the strip; Fig. 5, a view of the under side of the working parts; Fig. 6, a horizontal section taken at the line  $x x$  of Fig. 2, showing the devices for effecting the feed of the nail-strip in one position; Fig. 7, a similar view, with the devices in their changed positions; Fig. 8, a view in perspective of the movable jaw, its carrying-arm, and its bearing-sleeve detached from the machine; Fig. 9, a view in perspective of the shifting nail-strip carrier detached from the machine; Fig. 10, a horizontal section through the nail-carrier and its feeding-rolls, and showing the converging strip-feeding channels centrally with the driver, and with which each is brought in line by shifting the carrier; Fig. 11, a front view, showing the fixed and movable jaws removed to show the relation of the strip-feeding channels with the driver; and Fig. 12, a horizontal section at the line  $2 2$  of Fig. 2.

The machine consists of a working head mounted upon a pedestal, and provided with a jack or horn, (not shown,) for holding the stock in the usual manner for presenting the work to the action of the machine.

The head, as shown, consists of a single casting,  $a$ , in which all the working parts are mounted for co-operation; but it may be of any suitable construction. The front plate carries the driver-slide  $s$ , which has its vertical reciprocating motion imparted to it by a cam,  $c$ , formed in the balance-wheel, with which the slide connects by a cam-roller mounted upon the upper end of a vertical shaft,  $s^2$ , secured in bearings in the frame, and which connects with and operates the nail feeding, cutting, and forming devices at its lower end. The driver-slide  $s$  works in suitable ways, and carries the steel-driver  $d$  proper in a vertical position, and for action upon the nail, between a fixed and movable jaw,  $j$   $j^2$ , arranged to perform their proper function in the line of the driver, and at the front of the head. The combination of these jaws with the driver serves the important purposes of first severing a nail from the strip which is fed in position; secondly, subjecting the

nail to a compressing action while and after being cut to form the head; thirdly, to form the pressing-nose, against which the jack or horn holds the work; and, fourthly, to serve as a guide for the nail while being driven into the sole.

The fixed member  $j$  of the jaws is secured to the front plate, and the movable member  $j^2$  is carried by an L-arm,  $b$ , pivoted by one branch,  $b^2$ , to the main frame, and connected by the other arm to an eccentric pin,  $e$ , Fig. 2, on the lower end of the vertical shaft  $s^2$ , by means of a connecting-rod,  $e^2$ , having a ball-joint union,  $e^3$ , Figs. 8 and 12, with the jaw-arm  $b$ , to accommodate the joint action of the movable jaw and its operating eccentric pin  $e$  in opening and closing the jaw. This connecting-rod  $e^2$  is made adjustable by a screw,  $e^4$ , bearing upon the ball of the connecting-arm of the eccentric pin, for the purpose of compensating for any wear in the acting or cutting edges of the nail-forming jaws.

The movable jaw  $j^2$  opens and closes in the arc of a circle flush with the front end of the strip-carrier, and the strip is received from the carrier between the jaws, as shown in Figs. 3, 4, and 10. The jaws are of steel plates, and they are made removable for replacement by others, when desired. They are secured by screw-bolts; but these would not afford the requisite holding power, and hence I buttress them in the frame and the movable jaw by abutments  $a^2$   $a^2$ , which give top and side supports, and render them as solid as if they were part of the frame, while the arm  $b$  of the movable jaw has a bearing against an extension,  $a^3$ , in the frame nearly equal to its length, to prevent any possible tendency to depart from a horizontal plane of action while bringing the cutting-jaw against the strip.

Each acting part of the jaws is formed with a groove terminating in vertical-cutting side edges, as shown in Figs. 8 and 12, so that when closed they form a complete circle, and within which the severed nail is received and its head compressed, and reformed into any desired shape, preferably a cylindrical head, it being understood that this head is reformed preferably from a top-edge shouldered strip,  $Z$ . The reforming of the head is to take out any defect therein which might occur under the operation of severing it from the strip, and to give uniform symmetry to the heads of the nails.

The grooves form the feeding-guide for the nail when the jaws are closed, and are therefore of a diameter equal to that of the head to be reformed, so that in driving out the nail the head will readily pass out under the action of the driver, which is of a diameter equal to that, or nearly so, of the groove formed by the closed jaws. In forming the head of the nail the closing action of the jaws compresses the metal and holds the nail so firm that it would be impossible to drive it through the jaw-guide without breaking the driver; and to obviate this difficulty the pressure upon

the nail between the jaws is slightly relaxed to release the nail just before it is struck by the driver, yet being subjected to a sufficient degree of pressure to form a close guide, through which it is driven into the sole. This action is effected by the co-operation of the eccentric pin *e*, the connecting-arm *b*, and the cam *c*, the eccentric pin *e* passing its greatest point of eccentricity just previous to the driver being acted upon by the cam *c*.

The carrier *A*, for the nail-strips, is of peculiar construction, and is arranged in a horizontal position beneath the frame and in rear of the driver, with its feeding end contiguous to the inner surfaces of the fixed and movable jaws, so as to feed the strips into and through the opening between the jaws. It is suspended by a sleeve, *f*, which passes through a long socketed boss, *f*<sup>2</sup>, on the rear side of the front plate, and is concentric with a strong vertical stem, *g*, by which the nail-strip carrier is also suspended from the same socketed boss, and by which both the carrier and the movable jaw move in concentric arcs with the inner end of the nail-strip carrier in position flush with the inner faces of the jaws. The short arm *b*<sup>2</sup> from the movable jaw, by this construction, plays over and flush with the upper side of the nail-plate carrier, as shown in Fig. 11, whose front end is made smaller than its rear end, as shown in Figs. 9 and 10, and is made rounded at its sides, back of its acting-point, to fit closely within a recess in the lower end of the front plate and the contiguous portion of the movable jaw-arm. The nail-plate carrier is capable of being vibrated upon its sleeved stem *g*, which is near the front end, in order that this end will have a much less movement than the rear end, which projects some distance back, and is enlarged to receive the feeding devices for the nail-strips, and within which to form two ways or guides, *h*, Fig. 10, for two nail-strips. These ways or guides converge from the rear to the front end of the carrier, and are concentric with a radius of about six inches in order to obtain a proper and easy direction for the feed of the strips. These ways or strip-guides are open at both ends, and conform in their cross-section to that of the nail-strip, which is passed into the carrier from the rear end.

The object of this construction and arrangement is to feed nail-strips of different widths for use in uniting different thicknesses of material, such as the sole from ball to ball, which require nails of a longer length than those for the shanks. Nail-strips of unequal widths are therefore fed into the separate guideways, and one strip is operated upon at a time, and to effect this the carrier is vibrated upon its sleeve-stem to bring the inner end of each guideway at a time in position to feed the strip to the severing and forming, just in line with the driver. The curve of the nail-strip passages must be such, in connection with the movement of the strip-carrier, so that

when the carrier is vibrated upon its pivot *g* its point of delivery will be in a direct line under the driver, which forms a fixed point, where both of the curves described by the strip-passages come in line with the same point. Were it not for this arrangement the direction in which the nail-strips move would not be in harmony with the action of the driver and jaws.

The nail-strip is fed so that the jaws sever and drive one nail at a time by the following means: A strong back-piece, *i*, rises from the rear end of the carrier *A*, passing through an opening, *j*<sup>3</sup>, in frame, and is provided with two vertical cylindrical openings, within which are fitted feed-spindles *k*, which pass through the carrier, and extend above the back-piece. Their lower portions have milled surfaces, as shown in Fig. 10, in a line with and entering the strip guideways *h*, to form a biting-surface against the inner side of the strip and feed it to the jaws between rolls *i*<sup>2</sup> *i*<sup>2</sup> as the spindles are turned. The upper ends of the spindles are provided with ratchet-wheels *l*, and into these, whichever one being in use for the time, a pawl, *m*, is caused to take, to turn the spindle to give the required length of movement to the strip. This is effected by a yoke-slide, *n*, to the sides of which the pawls *m* are pivoted, and from which a stem, *n*<sup>2</sup>, projects into a guide-socket in the frame-standard, and which slide *n* is connected with and operated by a cam-groove, *n*<sup>3</sup>, formed in the under side of a sleeved disk, *n*<sup>4</sup>, by means of a pin rising from said slide, and provided with a roller, (shown in Fig. 2,) which, in traversing said groove *n*<sup>3</sup>, gives to the yoke *n* a reciprocating movement, in which the pawls *m* are caused to act upon the feed-rolls *l* *k* on the advance of the slide.

The pawls are maintained in acting positions by springs bearing upon their rear ends outward, and as the movement of these pawls is constant and equal, each one is therefore always in readiness to act whichever way the strip-carrier may be shifted. In this the throw of the strip-carrier is limited by the ends of the slot *j*, within which the back-piece *i* moves, and thereby brings the ratchet-wheel *l* in contact with the feeding-pawl *m* on one side only, and at the same instant disengaging the opposite pawl, thereby insuring the certainty of feeding the strip to cut the nails. The accomplishment of this thing involves the necessity of an actuating device for the shifter, which, while having a positive action, must accommodate itself to the action of the jaws by applying the force at any time to shift the strip-carrier, whether it be ready to be shifted or not—or, in other words, apply the force and hold it in suspension until the obstruction is removed by the severing of the nail from the strip, at which point the suspended force is made active and automatic in its function to shift the strip-carrier to use the wide or narrow strip, as may be required for the particular part of the work being nailed. For this

purpose I combine, with the nail-carrier, a triangular driver,  $p$ , centrally pivoted to an extension of the lower bar of the frame by a stem, so as to be vibrated thereon. The point of this pivoted driver has a notch,  $q$ , which takes into and maintains its hold with a tooth or projection,  $q^2$ , Fig. 12, upon a slide-bar, B, fitted into a horizontal opening in the cross-bar of the frame, just in rear of the back-piece  $i$ , rising from the nail-carrier, and with a notch,  $r$ , in which a tooth,  $r^2$ , or projection from the front side of the slide-bar B takes and forms a lock between the pivoted driver  $p$  and the nail-carrier, as shown more clearly in Fig. 12, Sheet 3.

The rear side of the pivoted driver  $p$  has a concave form, having a projecting point,  $s$ , at each end of the curved surface to form guards for the actuating lever. With this pivoted device I combine a shifting-lever,  $t$ , pivoted to the extension of the frame, and provide its front end with a bearing-tongue,  $u$ , having a central longitudinal position in said lever for action upon the concave surface of the pivoted driver  $p$ . The bearing-tongue moves in a guide in the lever  $t$ , and a coiled spring in the latter constantly presses upon the inner end of the stem of the bearing-point to force it outward. This pivoted lever  $t$  is operated by a handle,  $v$ , extending from its side; and the limit of its vibration, as well as that of the pivoted driver  $p$ , is determined by the throws of the rear end of the nail-strip carrier, which, as before stated, is limited by the ends of the slot  $j^3$ , within which the back-piece plays. This movement must be such as to give only an extent of movement to the front end of the strip-carrier A, equal to the distance between the front ends of the strip-guides  $h$ , to bring each one in line with the driver. The pivots of the triangular driver  $p$ , and its actuating lever  $t$ , are in line, and when the actuating lever is in position to correspond with such line there will be no action of the pivoted driver, and the bearing-slide  $u$  will have its maximum rearward movement within its socket, while the strip passages will be on opposite sides of the driver, as shown in Fig. 12. The least movement of the actuating lever  $t$  either way allows the slide-point  $u$  to exert its force on one arm of the triangular driver  $p$ , and turn it quickly on its pivot, and thus throw the slide-bar B, and with it the rear end of the nail-carrier A, to one side in position to feed the proper nail-strip. Upon reversing the movement of the operating lever  $t$  the opposite adjustment of these parts will take place; in either of these adjustments the triangular driver  $p$  and its lever  $t$  serve to hold the nail-carrier securely in position. The feed of the work is made by a foot,  $w$ , carried by a bar,  $w^2$ , pivoted to an extension at one side of the frame, the pivot-bolt C passing through a slot,  $w^3$ , in the frame, and also in the bar, while the upper end of the bar is hung upon an eccentric pin,  $x$ , on the end of a short shaft,  $x^2$ , which carries at its opposite

end a bevel-gear wheel,  $x^3$ , which matches with a bevel-wheel,  $y$ , upon the driving-shaft. The action of the eccentric pin  $x$  is to give the required lift and descent of the foot, while the point of pivot C in the bar  $w^2$  determines the feed of the work, to make it either coarse or fine, according as the pivot-pin C may be adjusted in the slot. The cam  $e$ , for operating the driver, is formed upon the circumference of a horizontal wheel,  $e^2$ , which serves the function of a balance-wheel; while also making, by reason of the sharply-formed cam  $e$ , a quick blow, which is absolutely necessary. In this function the weight of the balance-wheel adds very considerable advantage, and in fact is a material point to the successful operation of the machine. In addition to this the balance-wheel and the cam-driver also form the cone  $c^3$  for the friction-pulley catch  $c^2$ , such cone being formed upon the upper surface of the balance-wheel, as shown in Fig. 2, and the friction-pulley clutch is carried in horizontal position by a lever, D, with which it has a swiveling connection, and which being pivoted to the standard is pivoted to the treadle, and put into and out of action by the depression and release of the treadle by the operator. An adjustable gage,  $z$ , for the edge of the work to be moved against to determine the distance at which the nails are, to be driven from the edge of the work, is carried by the lower part of the head and fastened with a set-screw.

In the drawings, Z, Sheet 2, represents cross-sections of shouldered nail-strips of different widths, as used in my nail-strip machine; but nail-strips of any suitable form in their cross-section may be used so long as they are adapted to be carried and fed to the jaws in the way described.

The following is claimed as new in shoe-nailing machines, namely:

1. In a machine for nailing boots and shoes with nails cut from a strip, the combination, with the driver  $d$ , of jaws  $j j^2$ , between which the nail is cut from a strip and the head formed by compression by the same movement which effects the severance of the nail, substantially as herein set forth.

2. The combination, in a machine for nailing boots and shoes, of jaws  $j j^2$ , adapted to sever a nail from the strip, then compress the nail and form a head, and become a tube and guide for the nail and driver, substantially as and for the purpose described.

3. The combination, in a nail cutting and driving machine for boots and shoes, of a driver,  $d$ , and a nail-strip carrier adapted to feed the strip and deliver the severed nail to a compressing and head-forming tube directly in the line of the driver without transfer of the severed nail from the point of entrance, substantially as and for the purpose stated.

4. The combination, in a nailing-machine for boots and shoes, of a driver, cutting-jaws, nail-compressing and head-forming tube and guide, and a carrier adapted to automatically deliver

nail-strips of different widths, as may be required, directly in the line of the driver and the jaws, essentially as herein set forth.

5. The combination, in a nailing-machine for boots and shoes, of a driver, *d*, with a fixed cutter, *j*, and a jaw, *j*<sup>2</sup>, having a movement toward and from the fixed jaw, the two forming a nail-compressing tube-guide when closed, substantially as and for the purpose stated.

6. The combination, in a nailing-machine for boots and shoes, of a nail-driver, a nail-strip carrier, and jaws having cutting-edges, and a nail-forming guide into which the nail-strip is fed, the nail cut, and its head formed thereby, and driven through said guide-jaws to complete the operation, substantially as herein set forth.

7. The combination, in a nailing machine for boots and shoes, of a nail-driver, a nail-strip carrier and jaws having cutting-edges, and adapted to compress the nail and form a head thereon, with mechanism for operating the jaws, substantially as herein set forth.

8. In a machine for nailing boots and shoes, the jaws *j j*<sup>2</sup>, with cutting-edges, forming, when closed, a nail-tube or guide for compressing the nail and forming a head thereon, and adapted, one or both, to automatically yield or open slightly just previous to the descent of the driver, substantially as and for the purpose described.

9. The combination, with the movable jaw *j*<sup>2</sup> and its carrying-arm *b* in a nailing and driving machine, and the eccentric *e*, by which said jaw is operated, of the adjustable ball-and-socket-joint brace-connection *e*<sup>2</sup> *e*<sup>3</sup> *e*<sup>4</sup>, whereby the cutting-jaw has a positive action directly from the driving-shaft, substantially as herein set forth.

10. The combination, in a nailing-machine for boots and shoes, of a nail-strip carrier, *A*, having a vertical back-piece, *i*, carrying the feeding-ratchet stems *k k l l* for the nail-strips, with automatic operating ratchet-pawls *m*, carried by a yoke-slide, *n*, and operated by an eccentric-cam, *n*<sup>3</sup>, on the driving-shaft *s*<sup>2</sup>, whereby the feed of the nail-strip is effected with certainty, substantially as herein set forth.

11. The combination, in a nailing-machine for boots and shoes, of a shifting nail-strip carrier, *A*, having two separate and independent nail-guides, *h*, and a vertical back-piece, *i*, carrying two separate and independent feed-ratchet stems, having milled feeding portions *k*, with a horizontally-operating cam-yoke, *n*, carrying two separate and independent ratchet-pawls, *m*, whereby either ratchet-pawl can be engaged, and the other rendered inoperative by throwing the nail-strip carrier from one side to the other, without arresting the action of the machine, substantially as herein described.

12. The combination, in a nailing-machine for boots and shoes, of a nail-strip carrier, *A*, with the movable jaw-carrier *b*, the pivot-stem *g* of the former being concentric with and inclosed by a sleeve-bearing, *f*, of the jaw-car-

rier, whereby the adjustment of said strip-carrier is made concentric and in co-operation with the action of the movable jaw, substantially as herein set forth.

13. The combination, in a nailing-machine for boots and shoes, of a nail-strip carrier, provided with a vertical back-piece, *i*, which carries the feeding-ratchet stems *k l* of a stop-opening, *j*<sup>3</sup>, within the frame, and within which the back-piece moves, the ends of which opening serves to limit the throw of the strip-carrier to bring the front end of the strip-guides therein at a point in line with the driver and the opening between the jaws, substantially as herein set forth.

14. In a nailing-machine for boots and shoes, a pivoted nail-strip carrier, having nail-strip passages *h h*, in combination with the driver and a nail-forming tube and guide, to which it operates to feed and deliver nail-strips of different widths, substantially as herein described.

15. The combination, in a nailing-machine for boots and shoes, of a pivoted vibratable nail-strip carrier, *A*, having a vertical back-piece, *i*, carrying the feeding-ratchets, with a shifting slide-bar, *B*, seated in the frame, and suitable devices for imparting it to a sliding movement to shift the nail-carrier, substantially as herein set forth.

16. The combination, in a nailing-machine for boots and shoes, of a vibratable nail-strip carrier, *A*, and the slide-bar *B*, with a device for applying the changing force to shift such carrier irrespective of the operation of the jaws, whereby an automatic shifting movement of the nail-strip carrier is effected previous to the feeding and cutting of the next nail, and without arresting the action of the machine, and without regard to the action of the jaws, substantially as herein set forth.

17. The combination, in a nailing-machine for boots and shoes, of a vibratable nail-strip carrier, with a slide-bar, *B*, connecting therewith, a pivoted triangular driver, *p*, connecting with such slide-bar, and an actuating pivoted lever, *t*, having a sliding tongue, *u*, for operating upon the cam-face of the pivoted driver, substantially as and to produce the results herein set forth.

18. The combination, in a nailing-machine for boots and shoes, of the cutting and nail-forming fixed and movable jaws *j j*<sup>2</sup>, with the abutments *a*<sup>2</sup> *a*<sup>2</sup> in the frame, and movable jaw-carrier *b*, whereby a firm support is given the jaws to sustain them under their cutting and nail-forming action, substantially as herein set forth.

19. The combination in a nail-cutting and driving machine for boots and shoes, of a driver-bar, *s*, with its operating cam *c* formed upon the surface of the horizontal balance-wheel *c*<sup>2</sup> of the machine, whereby the blow of the driver is derived directly from the balance-wheel upon the main shaft, substantially as herein set forth.

20. The combination, in a nailing, cutting,



and driving machine for boots and shoes, of a driver-bar, *s*, and its operating cam *c* and balance-wheel *c*<sup>2</sup>, with the friction-clutch pulley *c*<sup>4</sup>, whereby the balance-wheel of the machine serves the several purposes of a regulator for the speed of the machine, a driver for the driver-bar, and a means for applying the power and stopping the machine, substantially as herein set forth.

In testimony that I claim the foregoing as my own, I have affixed my signature in presence of two witnesses.

LOUIS GODDU.

Witnesses:

A. E. H. JOHNSON,  
J. W. HAMILTON JOHNSON.