

J. F. GORDON.  
Grain-Binder.

No. 163,480.

Patented May 18, 1875.

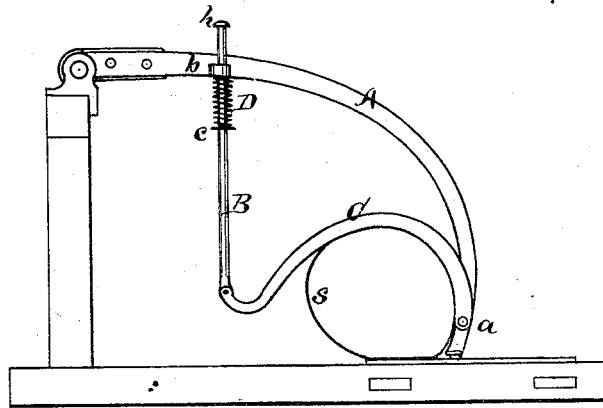

Witnesses.

E. B. Whitmore  
J. Telford

Inventor

Jas F. Gordon  
By Wm. Loughborough  
Atty

# UNITED STATES PATENT OFFICE.

JAMES F. GORDON, OF ROCHESTER, NEW YORK.

## IMPROVEMENT IN GRAIN-BINDERS.

Specification forming part of Letters Patent No. **163,480**, dated May 18, 1875; application filed October 3, 1874.

*To all whom it may concern:*

Be it known that I, JAMES F. GORDON, of Rochester, in the county of Monroe and State of New York, have invented a certain new and useful Compressing Attachment to Self-Binding Harvesters; and I do hereby declare that the following is a full, clear, and exact description thereof, reference being had to the accompanying drawing, making part of this specification, in which the figure is a side elevation of my invention as applied to the ordinary binder-arm.

The nature of this invention consists in the application to the binder-arm of self-binding harvesters of a compressor-bar, one end of which is attached to the binder-arm near its outer end, and the other by a suitable spring to a point near the axis of said arm.

It has been found that when the necessary compression of the gavel to form a bundle has to be produced entirely by the draft of the wire which is to form the band, much larger wire has to be used than is necessary for the band itself when the gavel is suitably compressed by other means.

The object of my present invention is to provide a simpler and more efficient means for accomplishing this automatically by the action of the binder-arm than the plan set forth in my former patent of June 16, 1874, upon which this is an improvement.

One end of the compressor-bar C is prefer-

ably pivoted to the binder-arm A, as shown at *a*, and the other end is hinged to the bar or brace-rod B, which passes loosely through the lug or ear *b* on the arm A. The head or cap *h* may be screwed on, and it prevents the rod from ever becoming detached from the lug. At a suitable distance below this lug the rod is provided with a shoulder or collar, and between this and the lug *b* is placed the compressing-spring D.

The position of the binder-arm and compressor-bar, as shown in the drawing, represents the parts as when the bundle is compressed and the band *s* applied. The tension of the spring D may be made adjustable, if desired, by making the collar *c* to slide on the rod B, and having its position or adjustment controlled by a nut or otherwise.

It might be desirable to slot the arm A and connect the bar C thereto at *a*, so as to allow it to rise or yield more or less as the arm descends, that end of the bar also being held down by a spring.

What I claim as my invention is—

In combination with the vibrating binder-arm A, the spring compressor-bar C, pivoted at or near the outer vibrating or swinging end thereof, substantially as set forth.

JAS. F. GORDON.

Witnesses:

WM. S. LOUGHBOROUGH,  
A. MANDEVILLE.