

T. L. WISWELL.

Portable-Sheds.

No. 163,559.

Patented May 18, 1875.

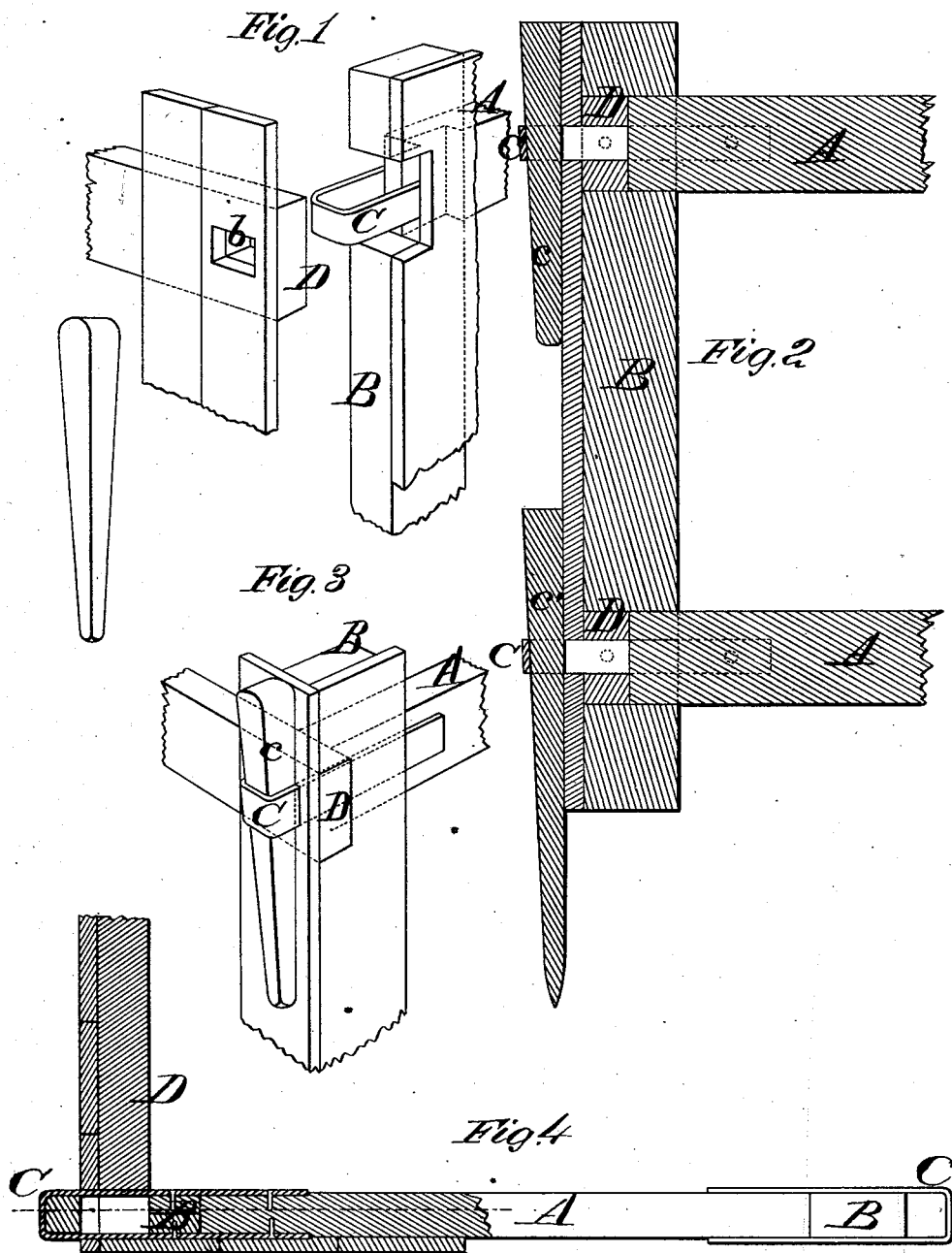

WITNESSES

*Villette Anderson.*  
*A. J. Haver*

INVENTOR

*T. L. Wiswell,*  
*Chipman & Son Co.,*  
ATTORNEYS

# UNITED STATES PATENT OFFICE.

THEODORE L. WISWELL, OF OLATHE, KANSAS.

## IMPROVEMENT IN PORTABLE SHEDS.

Specification forming part of Letters Patent No. **163,559**, dated May 18, 1875; application filed April 4, 1874.

*To all whom it may concern:*

Be it known that I, THEODORE L. WISWELL, of Olathe, in the county of Johnson and State of Kansas, have invented a new and valuable Improvement in Portable Sheds, &c.; and I do hereby declare that the following is a full, clear, and exact description of the construction and operation of the same, reference being had to the annexed drawings, making a part of this specification, and to the letters and figures of reference marked thereon.

Figure 1 of the drawing is a representation of a sectional view of my portable shed, and Fig. 2 is an end view of the same. Figs. 3, 4, 5, and 6 are detail views.

The object of my invention is to construct stables, cribs, bins, small sheds, and boxes of sections in such a manner that the sections can be readily put up and taken down and transported in a convenient manner.

The structure is composed of four close sides and a roof, the latter of which may be constructed in any suitable manner, and is not therefore claimed. Two of the vertical sides are composed of rectangular frames, having boards nailed to them. The other two sides of the structure are composed, respectively, of two horizontal bars, having boards nailed to them. The ends of the horizontal bars A A are halved upon the vertical bars B B, and permanently secured to them, the connections being rendered very substantial by the nails or bolts, which secure rectangular loops or staples C C to the frames at the junction of the bars A and B. At the ends of the bars A A the bars B have rectangular notches cut

into them, which will closely receive the ends of the horizontal bars D D of the other two sides forming the structure, as shown in Figs. 2, 3, and 4. The ends of the bars D D have rectangular holes *b* through them, through which the loops or staples C C are passed in putting up the structure, after which wedges *c c'* are driven through the projecting ends of the said loops, thereby firmly binding the parts and holding them rigidly together without any other fastening. The lowest wedges *c'* are made quite long, and being pointed they will enter the ground, and thus stake the structure thereto, preventing it from being blown over by strong winds.

It will be seen from the above description that, by simply withdrawing the wedges *c c'*, the four sides of the structure can be detached, packed into a small space, and conveniently and cheaply transported from one place to another.

Having described my invention, I claim as new and useful—

The bars A A B B halved together, in combination with bars D D, notched into bars B B, and confined thereto by means of staples C C and wedges *c c'*, in the manner and for the purposes described.

In testimony that I claim the above I have hereunto subscribed my name in the presence of two witnesses.

THEODORE LEROY WISWELL.

Witnesses:

H. S. BLAIR,  
W. M. DU MONT.