

J. CUSHMAN.
Wind-Mills.

No. 163,581.

Patented May 25, 1875.

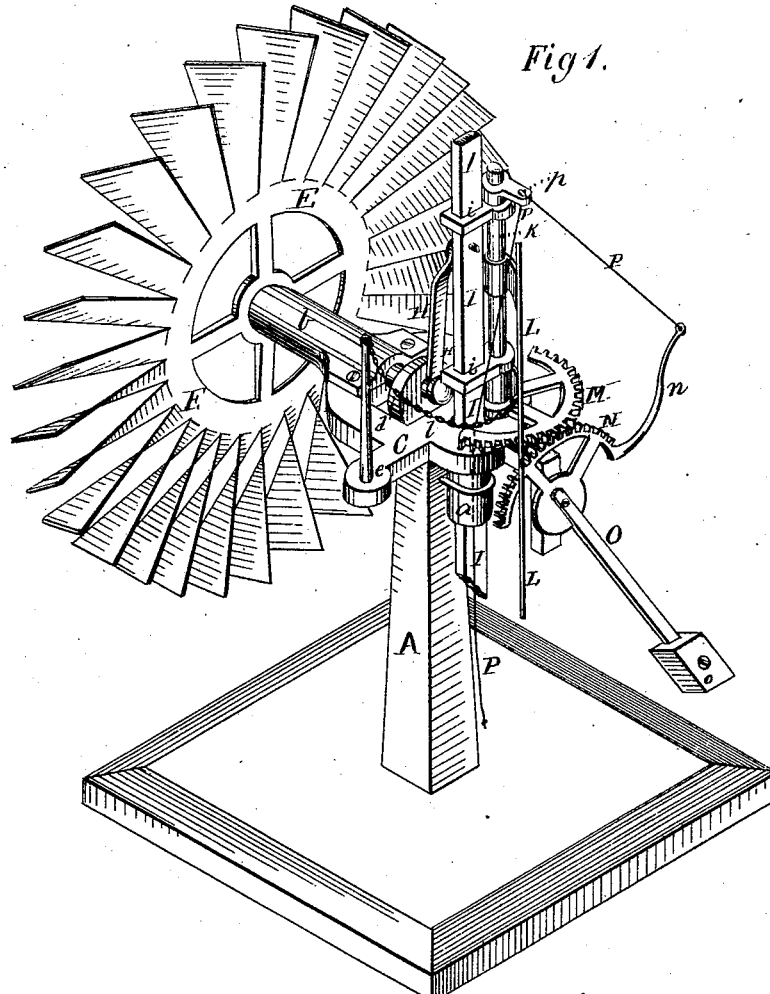

Fig 1.

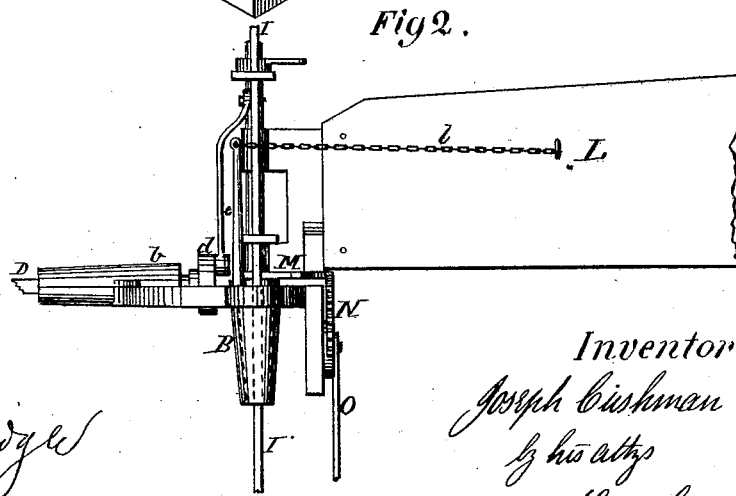

Fig 2.

Witnesses:
Chas. Gill
Thos. R. Goodbridge

Inventor:
Joseph Cushman
by his attys
Cox & Cox

UNITED STATES PATENT OFFICE.

JOSEPH CUSHMAN, OF THOMSON, ILLINOIS.

IMPROVEMENT IN WINDMILLS.

Specification forming part of Letters Patent No. **163,581**, dated May 25, 1875; application filed October 27, 1874.

To all whom it may concern:

Be it known that I, JOSEPH CUSHMAN, of Thomson, Carroll county, Illinois, have invented a new and useful Improvement in Windmills, of which the following is a specification:

The invention relates to improvements in windmills. It consists in a rod secured to the turn-table, and serving as the pivot of the guide-vane, the rod being placed out of the axial plane of the wheel-shaft, and provided with guides, in which moves the operating-slide, the latter element being connected, by a pitman-rod of peculiar shape, with a crank-head on the rear end of the wheel-shaft.

The peculiarities of construction, as well as other details, will appear in the description thereof hereinafter.

The object of the invention is to provide an effective form of windmill, and especially, by providing the vertical slide and pitman, and placing the former out of center with the wheel-shaft, to save power by avoiding friction, and also to furnish a ready and convenient means of controlling the guide-fan.

Figure 1 is a perspective view of a device embodying the elements of the invention. Fig. 2 is a detached view of a part of same.

A is an upright of suitable strength, at the upper extremity of which is the socket *a*, in which the thimble B, which is attached to the under side of the frame C, is fitted. The frame C is, preferably, principally metallic. Its forward part *b* is an elongated box, within which is the axle D of the wheel E, while its other parts are constructed to receive and accommodate the different parts hereinafter enumerated, as is shown with sufficient particularity in the drawings. At the extremity of the axle D removed from the wheel is the crank-head *d*, to which is eccentrically attached the lower extremity of the pitman H, its upper end being pivoted to the vertical slide I, to the lower parts of which, extending below the socket A, is attached the mechanism to which the power is to be applied. The slide I is set out of the vertical axial plane of the wheel-shaft D, for the purpose of preventing friction. The location of the shaft D and crank-head *d* is such, and the pitman H is so constructed, that the point of connection of the pitman and crank-

head, and the point of connection of the pitman and slide, are never in center. This is readily effected by placing the slide I a suitable distance upon either side of the axial plane of the wheel-shaft *d*, preferably, as in the present instance, to the left. K is a vertical rod attached to the frame C in proximity to the line of motion of the slide I, and is provided with the guides or ears *i*, within which the slide moves. The rod K serves, also, as a pivot for the guide-fan L and its incidents. The fan L is of usual construction, and is provided with the chain *l*, which is secured to the post *e*, whereby it is held away from danger. To the lower edge of the fan L, turning upon an eye upon the rod K, is rigidly secured the geared arc M, which meshes with the geared arc N, that is pivoted to a depending arm of the frame C, and provided with the lever O, having at its lower end the weight *o*. To the arc N is attached the lever *n*, the outer extremity of which is provided with an eye, through which is fastened the cord or rope P, which is carried over the eye or pulley *p* upon the rod K, and thence down, through the thimble B and socket *a*, to the base of the upright A. Thus, when power is applied at the lower end of the cord or rope P, the arc N meshing with the arc M, the fan is carried over against the post *e*, thus taking the wheel E away from the wind, when the cord may be made fast at pleasure.

I do not confine myself to the exact form of frame I have described, nor to the methods of attaching the divers parts; but

What I claim as my invention, and desire to secure by Letters Patent, is—

The pivot-rod K of the guide-vane, secured to the frame of the turn-table out of the axial plane of the wheel-shaft, and provided with guides *i*, in combination with the slide I and crank-head *d* of the wheel-shaft D, substantially as shown and described.

In testimony that I claim the foregoing improvement in windmills, as above described, I have hereunto set my hand and seal this 13th day of October, 1874.

JOSEPH CUSHMAN. [L. s.]

Witnesses:

S. B. SMITH,
M. SWITZER.