

W. DOYLE.  
Magazine-Stove.

No. 163,583.

Patented May 25, 1875.

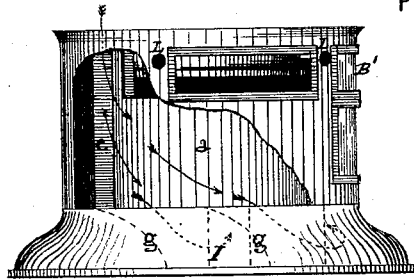

Fig. 1.

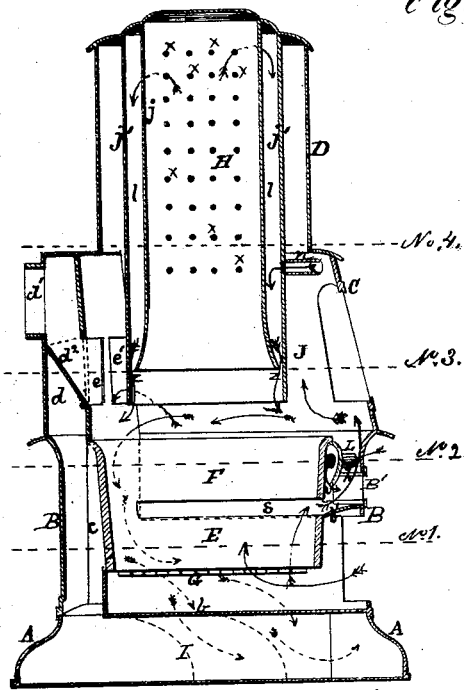

Fig. 2.

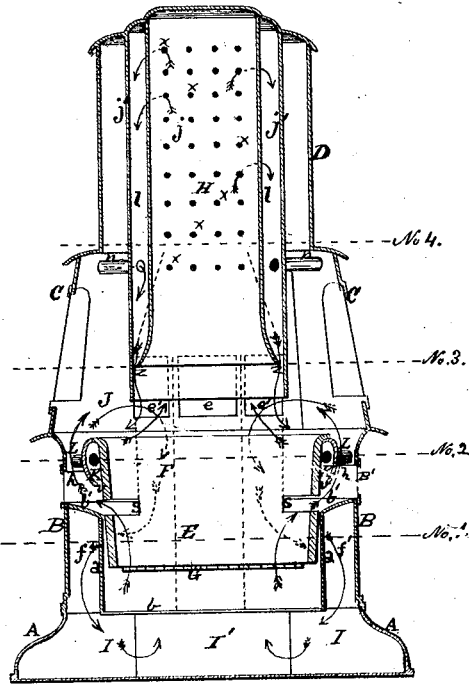
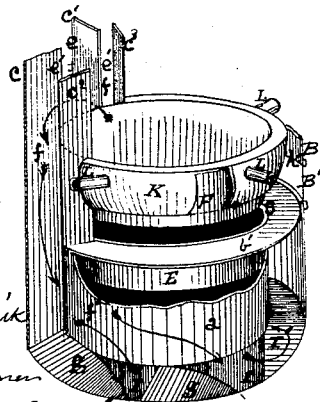

Fig. 3.



Witnesses. {  
Leht. J. Beckie  
James Conner  
Edward N. Doyle  
James Wright

William Doyle  
his Attorney  
Alex. Bellink  
Inventor.

W. DOYLE.  
Magazine-Stove.

No. 163,583.

Patented May 25, 1875.

Fig. 5.

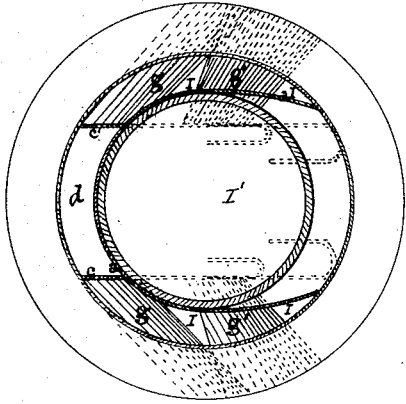

Fig. 7.

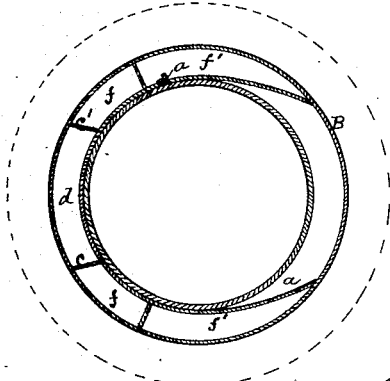
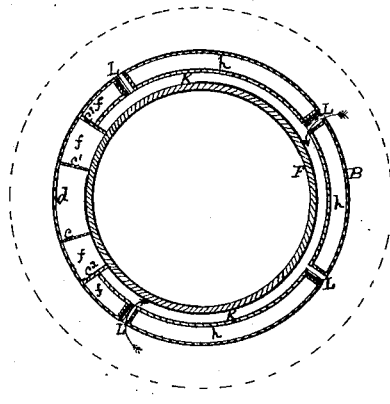

Fig. 6.

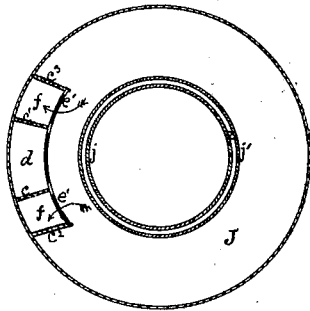

Fig. 8.

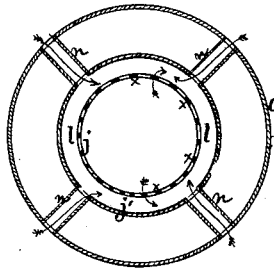

Fig. 9.

Witnesses. }  
Chas. J. Siskuk  
James. Connor  
Edward H. Doyle  
James Knight

William Doyle  
his attorney  
Alex. Bellink  
Inventor.

# UNITED STATES PATENT OFFICE.

WILLIAM DOYLE, OF ALBANY, NEW YORK.

## IMPROVEMENT IN MAGAZINE-STOVES.

Specification forming part of Letters Patent No. 163,583, dated May 25, 1875; application filed December 16, 1874.

*To all whom it may concern:*

Be it known that I, WILLIAM DOYLE, of the city and county of Albany, State of New York, have invented certain Improvements in Soft-Coal Self-Feeding Stoves; and I do hereby declare that the following is a description thereof, reference being had to the accompanying drawings, in two sheets, forming a part of this specification, in which—

Figure 1 is a side elevation of the section of the stove below the combustion-chamber, with a part of the outer wall broken away, illustrating parts of this invention. Fig. 2 is a sectional elevation of the stove, taken from front to rear. Fig. 3 is a sectional elevation, taken from side to side. Fig. 4 is a perspective view of the fire-pot and its immediate adjuncts. Fig. 5 is a plan view of the base-flues of the stove. Fig. 6 is a horizontal sectional view, taken at line No. 1 in Figs. 2 and 3. Fig. 7 is a horizontal sectional view taken at lines No. 2 in Figs. 2 and 3. Fig. 8 is a horizontal sectional view, taken at lines No. 3 in Figs. 2 and 3. Fig. 9 is a horizontal sectional view, taken at line No. 4 in Figs. 2 and 3.

My invention relates to a soft-coal burner; and consists in the several parts hereinafter described, constructed and combined in such a manner as to render the stove capable of operating with soft coal in such a manner that the gases evolved may be consumed and be made by their combustion to effect a powerful heating of the stove in all its lower parts.

To enable others skilled in the art to make and use my invention, I will proceed to describe it in reference to the drawings and letters of reference marked thereon, the same letters indicating like parts.

In the drawings, A represents the base section of a stove. B is the fire-pot section. C is the mica section surrounding the combustion-chamber. D is the top section. E F is the fire-pot. G is the grate. H is the fuel-reservoir.

In my invention I form the fire-pot with two sections—the lower section E, in which the fuel is burned, and the upper section F, in which the fuel is coked, as shown in Figs. 2, 3, and 4. The said sections may be cast solid with each other, or be united together at the rear,

with the space *s* between the lower end of the upper section and the upper end of the lower section, as shown. *a* is a vertical plate supporting the lower section of the fire-pot from the bottom plate *b*. *b'* is an annular plate extending from the top margin of the lower section E of the fire-pot to the outer wall or casing B, to cut off all communication of the space outside the said lower section of fire-pot, with the space outside the upper section F. Around the upper and coking section F of the fire-pot, and forward of the flue-strips *c c'*, is the flame-space *h*, communicating from the space *s*, between the two sections of the fire-pot, to the combustion-chamber J above. Short descending flues *f f* lead from the combustion-chamber to the more extensive descending flues *f' f'*, located below the upper margin of the lower section of the fire-pot, and between the flue-strips *c* and *c'* and the sides of the ash-chamber door. The said flues *f* and *f'* are each the continuation of the other, and discharge into the flues I in the base of the stove.

The ascending flue *d* is provided with the damper *d<sup>2</sup>*, which damper, when turned, permits the drafts to be direct to the exit *d<sup>1</sup>* through the opening *e*. When the said damper is closed, the passage of the hot gases will be from the combustion-chamber, through the openings *e' e'*, into the flues *f f*, and into the base-flues, to return therefrom through the ascending flue *d*. The base-flues I at the sides of the base, and the central return-flue I', are preferably made as in a former invention, for which Letters Patent have been issued to myself, in which is employed the plates *g g'*, to throw the heated gases toward the side surfaces of the base, to effect a heating of the same, while the opposite sides of the plates *g g'* may themselves be heated to stimulate the actions of an adjoining flue, of which the opposite side of the said plates forms a part.

As before stated, around the coking section F of the fire-pot E F is the flame-space *h*, leading from the space *s* to the combustion-chamber J, through which the hot gases evolved in the lower section E escape to the said combustion-chamber as they pass out through the space *s*. An annular flue, K, ex-

tending from the flue-strip  $c$  to  $c'$ , as shown in Fig. 4, encircles the outer surface of the wall of the section F. The lower edge of the said annular flue is made with an opening,  $v$ , which communicates with the flame-spaces  $h$  and  $s'$ , which opening  $v$  extends from flue-strip  $c$  to  $c'$ .

Perforations may be employed in lieu of the continuous opening  $v$ , if desired. One or more air tubes or conduits,  $L$ , lead the air of the room, through the casing B and flame-space  $h$ , into the annular flue, to be heated for discharge through the space  $v$  into the said flame-space  $h$ , to be there mingled with the hot gases evolved from the lower section of the fire-pot, and drawn through the space  $s$  into the said space  $h$ , and so cause their perfect combustion. Set into the wall or casing B, surrounding the fire-pot, are the mica lights  $B'$ , Figs. 1, 2, and 3, which mica lights are intended to permit light and heat to radiate out into the room, as they are thrown off from the glowing coals in the space  $s$ , and from the flame from the ignited gases burning in the flame-space  $h$  opposite the said mica lights. The fuel-reservoir H is comprised by the cylinders  $j$  and  $j'$ . The cylinder  $j$  is provided in its upper portion with the several perforations  $x x x$ , and has its lower end made bell-shaped, or with a lateral spreading of its lower end. The outer cylinder  $j$  is made tight in its walls, and its lower end extends below the lower end of the inner cylinder. Between the said two cylinders is the chamber  $l$ , which communicates with the interior of the reservoir H through the ports or perforations  $x x$ . The said chamber  $l$  also communicates with the combustion-chamber J through the narrow annular space  $z$ , between the outer cylinder  $j$  and the lower spreading end of the inner cylinder  $j'$ . Several air pipes or conduits,  $n n$ , lead from the outside of the stove to the chamber  $l$ , surrounding the inner cylinder of the reservoir, and are intended to permit a supply of air to the said chamber, to mingle with the gases escaping from the interior of the reservoir, through the perforations  $x x$ , into the chamber  $l$ .

It is intended that by the draft of the stove, when in operation, the gases generated within the reservoir will be drawn from the same through the openings  $x x$  into the chamber  $l$ , while at the same time fresh air will be drawn from the room without through the tubes  $n n$  into the said chamber in a continuous manner, and both the air thus drawn in and also the gas drawn from the reservoir will be drawn down and discharged through the space  $z$  into the combustion-chamber J below, to mingle with the hot gases evolved from the fuel being coked in the upper section of the fire-pot, and those passing up through the flame-space  $h$  from the lower section of fire-pot thereby cause their combustion.

It is evident that, by reason of the reservoir being constructed with two cylinders, with an air-space between, there will be no excessive

generation of gas from the coking of the coals within the said reservoir, as is had in reservoirs formed with a single wall, where the coals may become highly heated.

It is also evident that as the air and gases are drawn downward in the chamber  $l$  they will be gradually heated, and when discharged through the space  $z$  into the combustion-chamber J that they may become highly heated at the time of their discharge, and so much so as not to damp the fire, as is the case where cold air is discharged over the top surface of the fire.

It is intended by the improvements in this invention to consume the fuel in the lower section of the fire-pot and coke the fuel in the upper section, while the fuel in the discharge end of the reservoir may be at a comparatively low temperature or state of ignition, so that the fuel may not become fused and adhere to the said discharge end to clog the same, or prevent a continuous flow to the fire-pot.

It is also intended that the draft of the stove shall draw the air into the annular flue K around the upper section, and cause a discharge of the same into the flame-space  $h$ , while at the same time the gases evolved from the fuel in the lower section of the fire shall be drawn through the space  $s$ , so that a perfect combustion of the gases may be had as they escape from the said lower section.

It is evident that, as the gases evolved from the top surface of the upper section are drawn by the draft toward the sides of the stove, they will be mingled with the flame or gases in combustion and drawn upward through the flame-space  $h$  to the combustion-chamber in their passage to the flues  $f f$ , and by the great heat of the same be consumed.

By the improvements in this invention it may be seen that all the gases evolved or generated may be consumed as they may be supplied at different points with highly-heated air brought in contact with an intense flame, as before described.

The rear ascending flue  $d$ , being located at the rear of the fire-pot, will become highly heated to stimulate the draft, and thereby cause a powerful draft to the air to be drawn into the flue K and the chamber  $l$ , and also the gases generated in the different portions of the stove, so that a combustion of all the inflammable portions of the fuel may be had at different points in close proximity or impingement with the outer walls or casing of the stove, above the lower section of the fire-pot, while the resulting hot gases will be drawn along the sides of the stove, and thence into the base to highly heat the same, for warming the room at a low point, by the heat radiated from the several lower portions of the stove, and the illumination secured in the flame-space may be more powerful, as it is had from both flame and glowing coals, which cannot be had in those stoves having mica lights set opposite a space having live coals only.

Having described my invention, what I

claim, and desire to secure by Letters Patent, is—

1. In a stove or heater, the combination of the sectional fire-pot, comprised by the coking section F and fuel-burning section E, with space *s* between, and the lower section provided with a grate, and its upper margin closing to the wall of the ash-chamber, with the flame-space *h* leading from the upper margin of the lower section to the combustion-chamber J, substantially as and for the purpose set forth.

2. The combination, with the sectional fire-pot, having a space between the sections, and a flame-space or passage-way, *h*, leading from the upper margin of the lower section of the fire-pot to the combustion-chamber above, of the air-heating flue K and tubes L, discharging into the said flame-space, substantially as and for the purpose set forth.

3. The descending flues *f f* and their extended continuations *f' f'*, leading from the combustion-chamber into the base-flues I and I', in combination with the flame-space or passage-way *h* and the mica lights B', set opposite

the flame passage or space *h*, whereby the stove may be rendered capable of warming a room from its lower parts by the united operations of the hot gases circulating through the said flues and base, and the heat radiated from the flame in the flame-passage through the mica lights, substantially in the manner set forth.

4. In a stove or heater, the chamber *l*, communicating with the interior of the fuel-reservoir, the outer air of the room, and the combustion-chamber, in combination with the flame passage or space *h*, surrounding the upper portion of the fire-pot, and the descending flues *f f*, leading the hot gases laterally from the discharge end of the reservoir, whereby the mingled air and gas from the chamber *l* may be drawn in contact with the flame and hot gases from the flame passage or space *h* for their better combustion, substantially as and for the purpose set forth.

WILLIAM DOYLE.

Witnesses:

EDWARD H. DOYLE,  
JAMES WRIGHT.