

W. W. MARSH.
Painting-Machine.

No. 163,598.

Patented May 25, 1875.

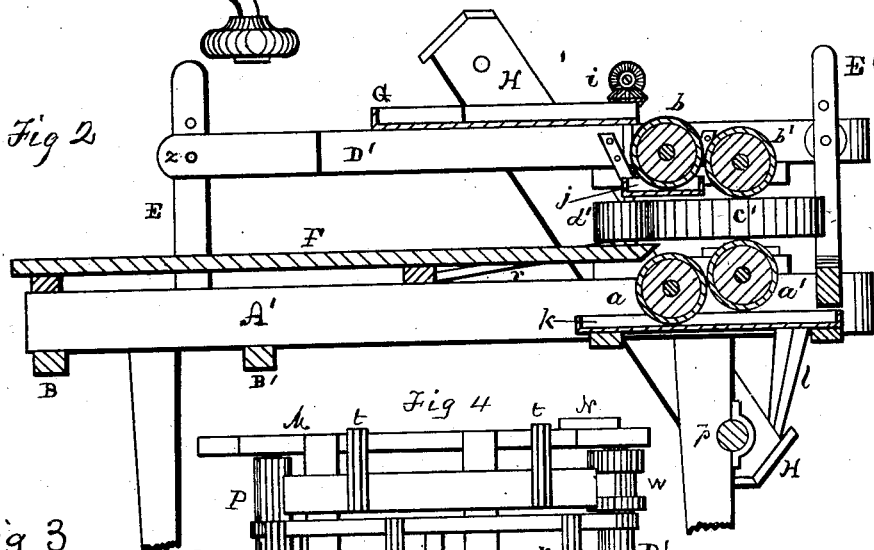
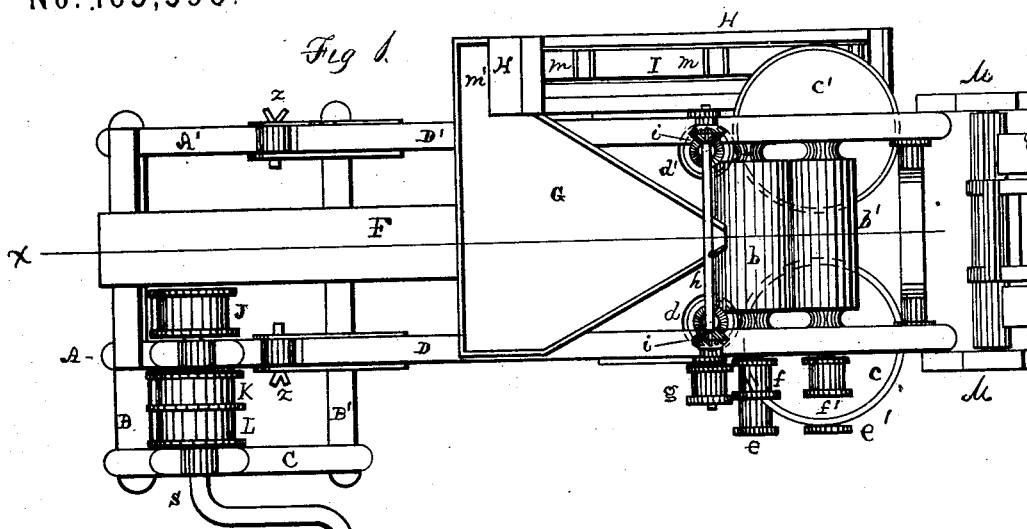
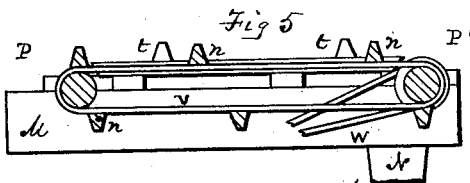
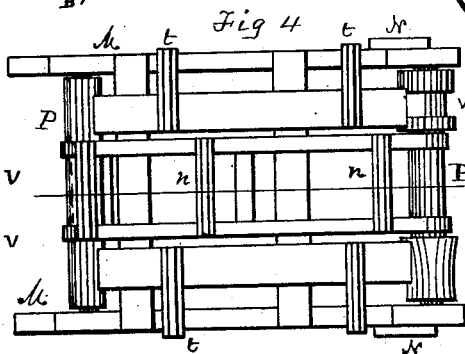

Fig 3



Witnesses:
O. W. Bond
Henry A. Saunders Jr.

Inventor.
William W. Marsh
By O. W. Bond Atty

UNITED STATES PATENT OFFICE.

WILLIAM W. MARSH, OF SYCAMORE, ILLINOIS.

IMPROVEMENT IN PAINTING-MACHINES.

Specification forming part of Letters Patent No. 163,598, dated May 25, 1875; application filed February 26, 1875.

To all whom it may concern:

Be it known that I, WILLIAM W. MARSH, of Sycamore, in the county of De Kalb and State of Illinois, have invented new and useful Improvements in Painting-Machines, of which the following is a full description, reference being had to the accompanying drawings, in which—

Figure 1 is a plan view; Fig. 2, a section on line *x* of Fig. 1; Fig. 3, a detail; Fig. 4, a plan view of a carrier and tables; Fig. 5, a vertical section of the same.

In many kinds of manufactories it becomes necessary to paint a very large number of pieces of the same size, and when this is done by hand it involves great labor.

The object of my invention is to construct a machine by the use of which pieces of the same size can be rapidly and efficiently painted on all sides at the same time, if desired.

In the drawings, A A' represent the side pieces of the main frame of the machine, having suitable cross-pieces at the ends, one of which, B, is shown. B' is another cross-piece, and it, as well as B, projects beyond the main frame, upon one side, to receive the bar C. This frame is supported on suitable legs. E E' are posts, extending up from the main frame. D D' are two longitudinal bars, pivoted at one end to the post E, at *z*, and secured at the other end to the posts E', by means of screws or bolts, so that by loosening this end of these bars they can be lifted up, with the parts attached thereto, to permit the insertion or removal of the paint-wheels *c c'*. F is a table, on which the stuff to be painted is placed to be fed to the machine. G is a pan to receive the paint, located upon the bars D D', above all the rollers. H is an elevator to carry up the surplus paint. I is the elevator-belt, on which are arranged buckets *m* in the usual way. J K L are fixed pulleys on the shaft S. *a a'* are two rollers, placed in suitable bearings in the main frame. *a* is a little lower than *a'*. *b b'* are two upper rollers, placed in suitable bearings in or attached to the bars D D'. *b* is a little higher than *b'*. *c c'* are two rollers for applying the paint to the sides of the stuff. *d d'* are two rollers, from which paint is dis-

tributed upon *c c'*. *e e'* are fixed pulleys upon the shafts of the rollers *a a'*. *f f'* are similar pulleys upon the shafts of the rollers *b b'*. *g* is a pulley on the shaft *h*, upon which shaft are two beveled wheels which engage with similar beveled wheels *i* upon the tops of the shafts, upon which are located the wheels *d d'*. *j* is a paint pan or reservoir, beneath the roller *b*. *k* is a paint pan or reservoir, beneath the rollers *a a'*. *l* is a spout to convey the surplus paint from the pan *k* to the elevator H.

The rollers *a b* are adjustable, either by being placed in adjustable bearings, or by means of a weight or spring, so that they can be located, relatively to the other rollers *a' b'*, as may be necessary for the required quantity of paint to be used. *a* is so arranged as to take up paint from the pan *k*, and *b* is so arranged as to take up paint from the pan *j*. In the back side of the pan *j* I make two notches, one over each of the distributing-rollers *d d'*, so that paint will overflow through these notches upon *d d'*.

The side rollers *c c'* rotate on a pin, *u*, Fig. 3, which is secured to a plate, which plate can be fastened in place by means of a screw, so that by loosening the screw, and turning the plate in or out, the wheels *c c'* can be adjusted within certain limits.

The rollers *a b* are designed to receive and take up the paint, and distribute it upon the rollers *a' b'*, which are the painting-rollers. The rollers *d d'* receive the paint and distribute it upon the painting-rollers *c c'*.

The bars D D' can be adjusted upon the posts E E', as may be necessary in painting different lots of pieces of different thicknesses; and in painting different lots of pieces of different widths side rollers *c c'* must be used of different sizes, it being easy to remove the rollers *c c'* from the pins *u*, and replace them with others.

The rollers *d d'* are so attached to their shafts that they can be easily removed, as when the rollers *c c'* are changed *d d'* must be changed to a proper size to be used with *c c'*. If necessary, spring-bars *r* may be so located as to press upward against the lower ends of the shafts upon which *d d'* are placed, so as to keep the beveled wheels on top thereof in

contact with those on the shaft *h*, and these springs will keep the beveled gear together, though the position of the bars *D D'* be somewhat changed.

The surface of the rollers *a b* and *d d'* may be either hard or elastic. The surface of the rollers *a' b' c c'* should be of some suitable material somewhat yielding or elastic.

The two rollers *a a'* are driven by means of a belt from the pulley *L*, the belt passing over *e* and around *e'*. Another belt from the pulley *K* drives the shaft *h* and the rollers *b b'*. The elevator-belt *I* is driven by a belt over the pulley *J*, and a fixed pulley on the shaft *p*.

The machine can be operated by hand or by power, and it may be run at a high rate of speed.

In use the two sets of rollers *a a' b b'* are to be adjusted according to the thickness of the stuff to be painted, so that when the stuff passes between the rollers *a' b'* they will press upon it and carry it through. Side rollers *c c'* are to be used, adapted both to the thickness and width of the stuff to be painted. Then pour a quantity of paint into the pan *G*, and start the machine. The paint will flow first upon the roller *b*, and be distributed upon *b'*. From *b'* it will pass into the pan *j*, from which pan it will overflow, at the rear, upon the distributing-rollers *d d'*, from which paint will be distributed upon the paint-rollers *c c'*. All the surplus will fall into the pan *k*, from which the rollers *a* will take up paint and distribute it upon *a'*. The surplus from this pan *k* will flow out, through the spout *l*, into the elevator, and be carried up by the buckets *m*, and emptied in the pan *G*, at *m'*.

By this machine one, two, or more coats can be efficiently applied, the pressure of the rollers forcing the paint into the pores of the wood much more thoroughly and evenly than when applied by hand.

By removing one of the rollers *d d'*, or by lowering the lower tank *k*, the operator can paint less than four sides, if desired.

In using the machine it will be necessary to keep a continual flow of paint, the surplus being carried around and around, while the required amount for covering the lumber will be taken out and evenly distributed thereon.

Any material change in the position of the bars *D D'* will render it necessary to change the shafts which carry the distributing-rollers *d d'*, which can most conveniently be done by having two or more sets of such shafts, provided with distributing-rollers at one end, and beveled gear at the other. The table *F*, the painting-rollers, and the receiving-table are all on a line.

When constructed as above, the painted

pieces can be received as they pass from the machine, and removed by attendants; but it will be found more convenient to connect with the machine a receiving-carrier and tables, consisting of the following parts: *M M* represent two side pieces, the inner ends being connected to *A A'*, and the outer ends supported by suitable legs *N*. *P P'* are two rollers, revolving in bearings in the side pieces *M*. *v v* are two belts, running over the rollers *P P'*, to which belts, at suitable intervals, are secured bars *n*, forming an endless carrier. Upon each side of this carrier, upon suitable supports, are bars *t t*, forming tables, to which the attendants can remove the painted strips for the purpose of painting the ends or touching up any imperfect spots. The roller *P'* is rotated by means of a belt, *w*, driven from the shaft *p*. When this portion of the machine is used the painted strips, as they pass from the painting-rollers, will be received upon the bars *n*, and carried along by the rotation of the carrier, from which they can be removed to the stationary tables, as before stated, by attendants. This attachment can be made of any suitable length.

Instead of the stationary table *F*, either rollers or an endless carrier might be used to feed the strips to the painting-rollers.

What I claim as new is as follows:

1. The combination of the distributing-rollers *a b*, painting-rollers *a' b'*, with paint-reservoir *G*, trough *j'*, drip-trough *k*, and suitable pulleys and frame, substantially as and for purpose specified.

2. The rollers *a a'*, *b b'*, *c c'*, and *d d'*, in combination with paint-receptacles *G j k* and suitable pulleys and supporting-frame, constructed substantially as and for the purposes specified.

3. The combination of the rollers *a a' b b' c c' d d'* with paint-receptacles *G j k*, table *F*, and suitable pulleys, and frame with adjustable bars *D D'*, substantially as and for the purposes specified.

4. In a painting-machine, the elevator *H*, in combination with paint-receptacles *G j k*, rollers *a a'*, *b b'*, *c*, and *d*, and suitable pulleys and frame, substantially as and for the purposes specified.

5. The distributing-rollers *a b*, and painting-rollers *a' b'*, in combination with the table *F* and a table to receive the painted strips, the rollers and tables arranged on a line, whereby long strips can be painted and the parts placed close together, as and for the purpose specified.

WILLIAM W. MARSH.

Witnesses:

C. W. MARSH,
A. M. STARK.