

J. Y. SMITH.  
 Car-Brake.

No. 163,612.

Patented May 25, 1875.

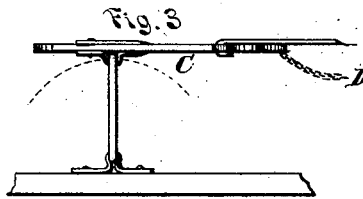
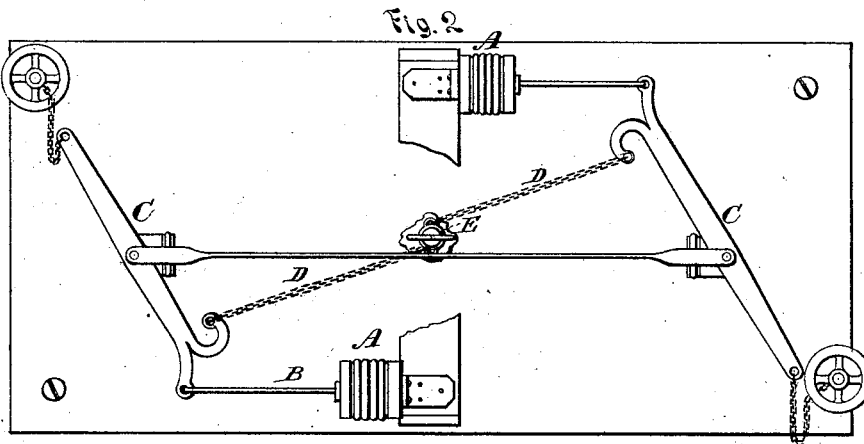
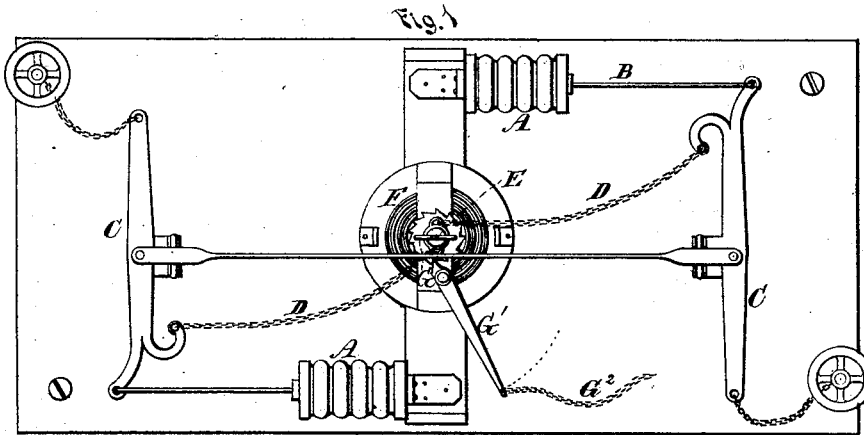

Witnesses.  
 A. Rupperts  
 J. R. Blanchard

J. Y. Smith  
 Inventor.  
 D. P. Holloway & Co  
 Attys.

# UNITED STATES PATENT OFFICE.

JOHN Y. SMITH, OF PITTSBURG, PENNSYLVANIA.

## IMPROVEMENT IN CAR-BRAKES.

Specification forming part of Letters Patent No. **163,612**, dated May 25, 1875; application filed April 6, 1875.

*To all whom it may concern:*

Be it known that I, JOHN Y. SMITH, of Pittsburg, in the county of Allegheny and State of Pennsylvania, have invented a new and useful Improvement in Safety Attachments for Vacuum-Brakes for Railway-Cars; and I do hereby declare that the following is a full, clear, and exact description of the same, reference being had to the annexed drawings making part of this specification, in which—

Figure 1 is a plan view of the bottom of a car reversed, with my improvements applied, the brakes not being applied. Fig. 2 is a similar view, showing the arrangement of the parts when the brakes are applied; Fig. 3, an elevation of part of the apparatus.

The same letters are employed in the indication of identical parts.

This improvement is intended to be applied to my vacuum-brake, and is designed to provide for the security of the train in case any of the cars should be separated from the train by accident or design, when, by the strain upon a cord extending through the train from the locomotive, the brakes would be automatically set on the detached cars; or, should the vacuum-brakes become inoperative, the engineer could instantly set all the brakes on the train by drawing the cord.

My invention consists in supplementing the diaphragms which bring the atmospheric pressure to act on the brakes by coiled springs attached to the bottom of the cars, midway between the brake-levers, and controlled by a ratchet and pawl; to the latter of which a cord is attached in such manner that, when it is drawn upon the pawl, will release the spring, and the latter will set the brakes.

In the annexed drawings, I have shown, at A, the flexible diaphragms used in operating the brake by exhaustion of the air. When the air is exhausted, the heads are forced toward one another by the pressure of the external atmosphere, drawing with themselves the ends of the levers C, which are connected, by the usual system of rods and levers, with the brakes. In order to provide against a failure upon the part of the diaphragms to op-

erate from whatever cause, I place in the middle of the under side of the floor of the car a spindle, E, having chains D attached, extending therefrom to the same arm of the levers C to which the rods connecting it with the diaphragm are attached. Around this spindle is placed a coiled spring of strength sufficient to set the brakes with the required force. The spindle may be turned by a crank applied thereto either through the floor of the car or from below. When the spring is thus wound up it is held by a ratchet and pawl, G, the chains D being relaxed and hanging from the spindle to which they are attached when the spring is thus wound up without being wound upon the spindle. A lever, G<sup>1</sup>, is attached to the pawl, and a cord, G<sup>2</sup>, extended from all the levers of the train to the cab within reach of the engineer or his assistant. When this cord is drawn upon, either by the engineer or by the separation of the cars forming the train, the pawls will be detached, and the springs will cause the chains to be wound upon the spindle, thereby drawing the brakes against the wheels in the same manner as though done by the contraction of the flexible diaphragms. The hand brake is attached to the other end of the levers C, operated in the usual manner.

In this arrangement I attach the hand-wheel to one end of lever C, and the vacuum-chamber and spring to the other, so that either of the three may be used, or all together, if rendered necessary by any emergency.

What I claim as my invention, and desire to secure by Letters Patent, is—

In combination with the transverse lever C to operate the brakes of a railway-car, the hand-brake, the vacuum-chamber, and the spring for setting the brake, substantially as set forth.

In testimony whereof I have signed my name to this specification in the presence of two subscribing witnesses.

JOHN Y. SMITH.

Witnesses:

A. RUPPERT,  
D. P. HOLLOWAY.