

A. BECK.

Instrument for Scribing Stair-Curves.

No. 163,626.

Patented May 25, 1875.

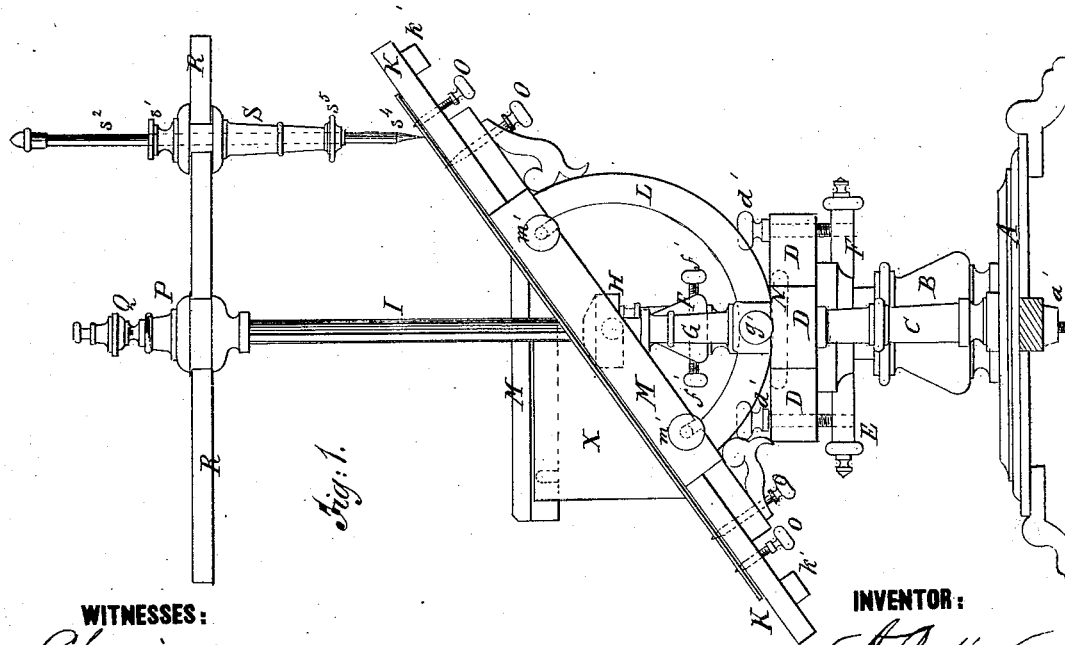
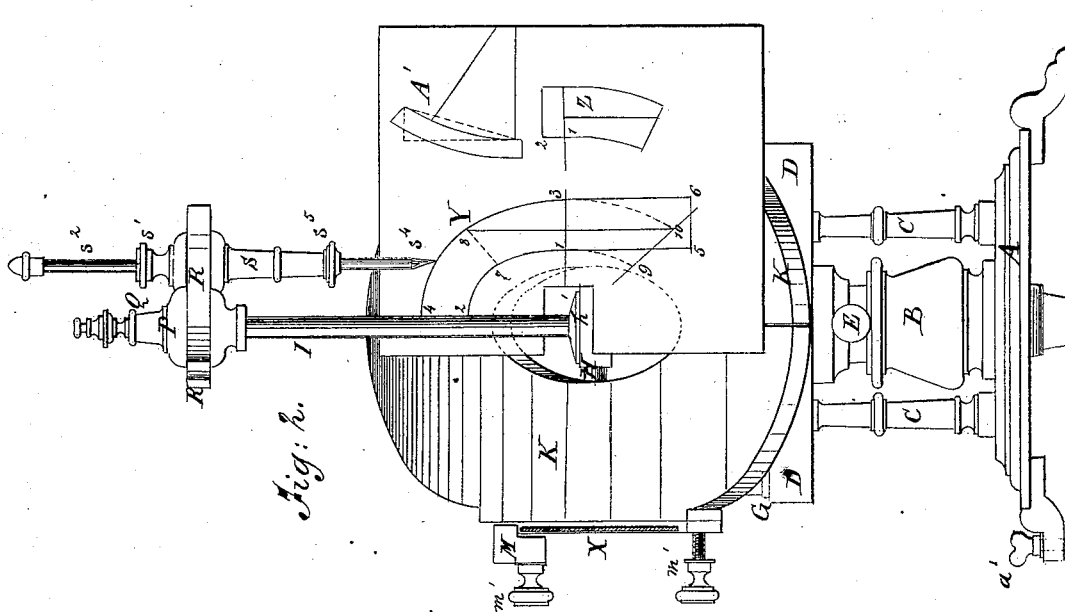

WITNESSES:

Chas. F. Roberts
Alex. F. Roberts

INVENTOR:

A. Beck

BY

ATTORNEYS.

A. BECK.

Instrument for Scribing Stair-Curves.

No. 163,626.

Patented May 25, 1875.

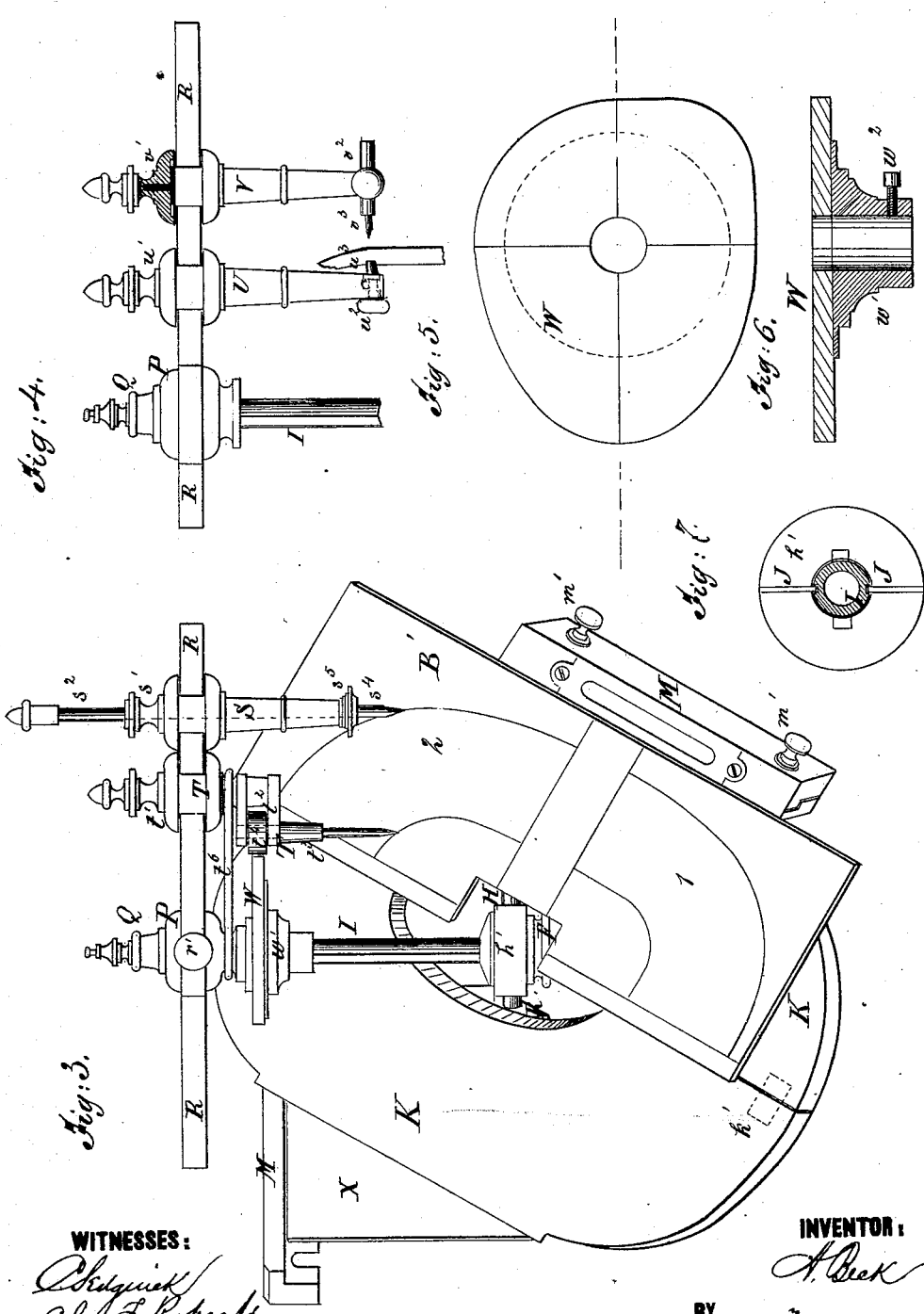

Fig. 4.

Fig. 5.

Fig. 6.

Fig. 7.

Fig. 3.

WITNESSES:
Abel P. Roberts

INVENTOR:
A. Beck
 BY *Munnell*
 ATTORNEYS.

UNITED STATES PATENT OFFICE.

ANDREW BECK, OF PHILIPSBURG, PENNSYLVANIA.

IMPROVEMENT IN INSTRUMENTS FOR SCRIBING STAIR-CURVES.

Specification forming part of Letters Patent No. 163,626, dated May 25, 1875; application filed May 16, 1874.

To all whom it may concern:

Be it known that I, ANDREW BECK, of Philipsburg, in the county of Center and State of Pennsylvania, have invented a new and useful Improvement in Stair-Builders' Drawing Instrument, of which the following is a specification:

Figure 1, Sheet 1, is a side view of my improved instrument. Fig. 2, Sheet 1, is a front view of the same. Fig. 3, Sheet 2, is a view, showing another adjustment of the same. Fig. 4, Sheet 2, represents another adjustment. Fig. 5, Sheet 2, is a plan view of the guide-plate. Fig. 6, Sheet 2, is a cross-section of the ellipse-plate and its hub taken through the line *x x* of Fig. 5. Fig. 7, Sheet 2, is a cross-section of the shaft.

Similar letters of reference indicate corresponding parts.

The invention will first be fully described, and then pointed out in the claims.

The invention consists in the combination of the base and its three posts, the rocking cross-bar and its three posts, and the upper cross-bar for supporting the shaft adjustably in place; in the combination of the arms and set-screws with the center-post and rocking cross-bar for plumbing the shaft; in the combination of the table-top, the curved bars, and the set-screws, with the upper cross-bar and the side posts; in the combination of the spirit-levels and their set-screws with the side edges of the table-top; in the combination of the head, the parallel bars and the set-screws with the shaft and the tilting table-top; in the combination of the arms, or either of them, with the parallel bars, the head, the shaft and the tilting table-top; and in the combination of the ellipse-plate and its hub and set-screw with the shaft, the head, the parallel bars, the arm and the tilting table-top, as hereinafter fully described.

A is the base of the pedestal, one or more of the feet of which is provided with a hand-screw, *a'*, to enable it to be set level and steady upon the floor. B is the center-post, and C are the two side posts, of the pedestal. The top of the center-post B is made circular in form, enters a circular recess made with beveled or inclined sides in the enlarged middle part of the cross-bar D, and has two semi-cy-

lindrical projections formed upon its top, upon the opposite sides of its center, which enter semi-cylindrical recesses in said circular recess, so that the cross-bar D may rock in its seat. The upper ends of the side posts C are rounded off and enter sockets in the under side of the cross-bar D, which sockets are made enough larger than the rounded ends of the said side posts to enable the said cross-bar to rock. E are two arms, attached to the upper part of the center-post B, at right angles to the cross-bar D, to receive the set-screws *d'*, which pass down through the middle part of the cross-bar D, to enable said cross-bar to be locked in place when adjusted. To the center of the cross-bar D is attached a center-post, F, and to its ends are attached the side posts G. To the upper ends of the three posts F G G is attached a cross-bar H, in the center of which is formed a box, *h'*, for the shaft I to pass through, the center-posts B F being made hollow for the passage of the said shaft. The shaft I is kept from turning by stops J, attached to the box *h'*, and which enter longitudinal grooves in the opposite sides of the said shaft I. The shaft I is locked at any desired elevation by the hand-screws *f'*, which pass in through the middle part of the center-post F. The forward ends of the hand-screws *f'* are covered by small springs, which are pressed against the shaft I by the advance of the screws *f'*, which prevent said screws from marring the said shaft and prevent the lower end of the shaft from striking against the forward ends of said screws when being lowered into place. The arms of the cross-bar H are rounded off to receive the bearings attached to the table-top K, so that the said top may be tipped or inclined upon the said cross-bar. The top K is made in two halves or parts, which may be locked in the same plane, when desired, by buttons *k'* attached to their lower side near their ends. The advantages arising from a two-part table is that it may be used either for drawing face-molding, or squaring the wreath. To the under side of the side parts of the top K, or to blocks attached to said parts, are secured the ends of the bars L, which are curved in the arc of a circle, and pass through holes in the lower parts of the

side posts G, where they are secured in place when adjusted, holding the top K, locked by set-screws g' , passing in through the sides of said side posts. M are spirit-levels, the lower parts of the inner sides of which are rabbeted to fit upon rabbets formed upon the side edges of the top K, where they are secured in place by hand-screws m' passing through transverse notches formed in the lower sides of the levels, so that they may be adjusted or removed by simply loosening the said hand-screws m' . A spirit-level, N, is also attached in a transverse position to the cross-bar D. O are sharp-pointed screws, passing up through the table-top K to hold the paper, block, or board upon which the drawing is to be done. Some of the screws O are long to hold the board when sprung. Upon the upper end of the shaft I is formed, or into it is screwed, a long tenon or journal, upon which is placed a head or hub, P, which rests and revolves upon the shoulder or collar of said journal, and which is kept in place, and locked in position, when desired, by a hand-nut, Q. Through the head P, upon the opposite sides of, and equally distant from, its center, are formed two square horizontal parallel holes, in which are placed two square bars, R, which are secured in place when adjusted by hand-screws r^1 passing in through the opposite sides of the head P. S T U V are arms, having parallel square transverse holes formed through their upper parts to receive and slide upon the bars R, when they are secured in place by hand-screws $s^1 t^1 u^1 v^1$. The arm S is perforated longitudinally to receive a rod, s^2 , and a pencil, s^4 . The lower end of the arm S is slotted, and is provided with a hand-nut, s^5 , so that the pencil can be clamped in any desired position. The arm T is made with an offset or shoulder, t^2 , upon it to bring its socket or pencil-holder t^3 nearer to the shaft I, and to its shoulder t^2 is pivoted a friction-wheel, t^4 , to roll along the edge of the ellipse or guide-plate W to push the said arm T outward as it is carried around the shaft I by the bars R. The arm T is held inward against the edge of the ellipse-plate W by an elastic band, t^6 , passing around the arm T, and around the neck of the head P, or by other suitable spring. The guide-plate W is provided with a hub, w^1 , through which the shaft I passes, and is secured at any desired elevation, and kept from turning, by a set-screw, w^2 , which passes through the said hub, and rests against the said shaft. The lower end of the arm U is slotted longitudinally to receive the set-screw w^2 , by which the stop w^3 is secured adjustably in place. The lower end of the arm V is provided with a horizontal holder, v^2 , the inner end of which is left open to receive a pencil, v^3 , which pencil is held out by a coiled spring placed within said tube v^2 .

I will now describe some of the uses of the instrument.

In using the instrument it is set steady upon the floor by the set-screw a^1 . The shaft I

is adjusted into a perpendicular position by moving the cross-bar D upon its seat until the spirit-level N is level. One end of the spirit-level M is then raised by loosening its set-screws m^1 . The pitch-board X is then placed under the level M in the rabbet of the top K, and the set-screw m^1 is tightened to prevent the level from moving. The set-screws g' are loosened to release the curved bars L, and the top K is inclined until the spirit-level M becomes horizontal, when it is secured in place by tightening the screws g' . The instrument is now set for drawing the draft Y, shown upon the board in Fig. 2. In making this draft, if the blank is to be sprung, a thin board should be used for making the pattern, and one side of the pattern should be raised with the long screws O. The arm S is then put upon the bars R in such a position that the pencil s^4 may rest upon the pattern at the point 1 in the diameter of the concave part of the rail. The shaft I is then raised until the pencil strikes the pattern at the point 2. The set-screws f' are then slackened until the shaft I will move down readily, the pencil making a plain mark upon the paper or board. The outer or convex line 3 4 is then drawn in the same way. 1 3 5 6 represent the straight part of the rail.

When the well of the stairs is too large to be made in one wreath, take the center of ground plan, draw the line 7 8 for the joint. Draw the dotted lines 1 9 and 3 10. Divide the floor plan as before, and draw the line 9 10, which gives the joint on 7 8. Draw the tangent line 8 10 at right angles with the line 1 3, and square down from the tangent 8 10 on the ends of the wreath or segment. Then apply the pattern to the under side of the tangent lines and pitch. Mark off the under part of the segment, which, when worked off and in position, will throw the concave and convex perpendicular. When it is necessary to make a joint in rail on line of diameter of well make straight part of rail parallel with center of top, square over from center of shaft, which will give the joint required. The diagram Z upon the board in Fig. 2 shows the manner of drawing the face mold or pattern for curtail step. From 1 to 2 shows the straight part of the rail. The diagram A' gives the plan of the pitch-board of the same. Fig. 3 represents the instrument in position for drawing the ellipse-face mold. To draw this pattern, place the ellipse-plate W upon the shaft I, with its center resting over the center part of top K. Fasten the plate W with the set-screw w^2 . Place the arm T upon the bars R. Put on the elastic band t^6 . Tighten the arm T upon the bars R with the hand-screw t^1 . Slacken the set-screws r^1 , so that the bars R will play freely in the head P. Put the arm S upon the bars R and fasten it with the hand-screw s^1 , and proceed to draw, as hereinbefore described, 1 on diagram. B' shows the face-mold of the quadrant W without the straight part of the rail attached to 1

and 2. To draw the quarter-sections of wreath 17 and 19, diagram Y, slacken the set-screw w^2 of plate W, turn it at right angles from where it stood with the marks on under edge of plate W with marks on shaft I. Then operate the instrument as shown in Fig. 2. For squaring the wreath shown in diagram Y, the wreath is worked on concave and convex sides, with the upper concave edge worked off to the falling mold. Set the instrument as shown in Fig. 2. Put on the arm U. Take the distance of the concave diameter of diagram Y. Tighten the arm U on the bars R. Then place the block or wreath upon the instrument with its concave edge upward. Place it down solid, so that the screws O will hold it to its place. Put the arm V upon the bars R and tighten the said arm in such a position as to spring the pencil back slightly, so it will mark upon the convex side of the wreath. Then raise the shaft I by slackening the set-screws f' , so that the shaft I will move freely. Set the stop $w^2 w^3$ of the arm U to the top or joint of wreath, and let it move down to the diameter of wreath. When dressed off to the line made by the pencil of arm V the squaring of the wreath will be completed.

Having thus described my invention, I claim

as new and desire to secure by Letters Patent—

1. The combination of the base A, three posts, B C, rocking cross-bar D, three posts, F G, and cross-bar H for supporting the shaft I adjustably in place, substantially as herein shown and described.

2. The combination of the arms E and set-screws d' with the center post F and the rocking cross-bar D for plumbing the shaft I, substantially as herein shown and described.

3. The combination of the table-top K, curved bars L, and set-screws g' with the cross-bar H and side posts G, substantially as herein shown and described.

4. The combination of the spirit-levels M and set-screws m' with the side edges of the table-top K, substantially as herein shown and described.

5. The combination of the ellipse-plate W and its hub w^1 , and set-screw w^2 , with the shaft I, head P, bars R, arm T, and tilting table-top K, substantially as herein shown and described.

ANDREW BECK.

Witnesses:

MATTHEW JOHNSON,
GEO. W. DAICY.