

C. B. DAVIS.
Lathe-Dogs.

No. 163,640.

Patented May 25, 1875.

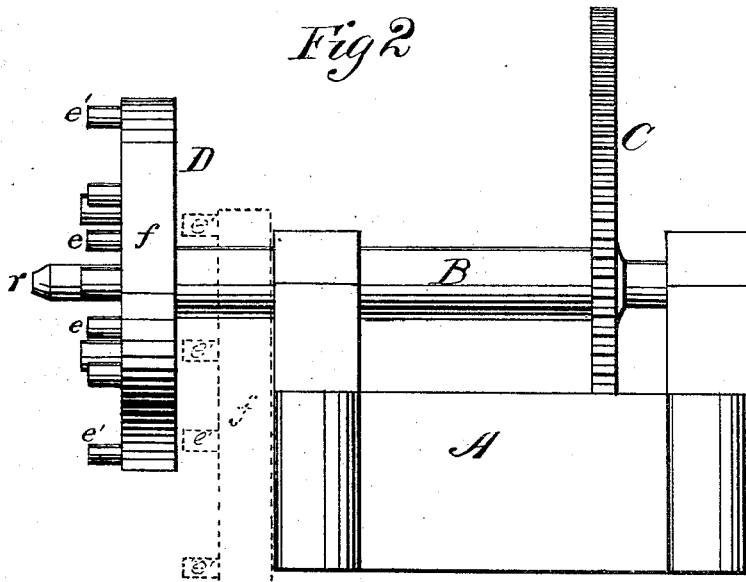
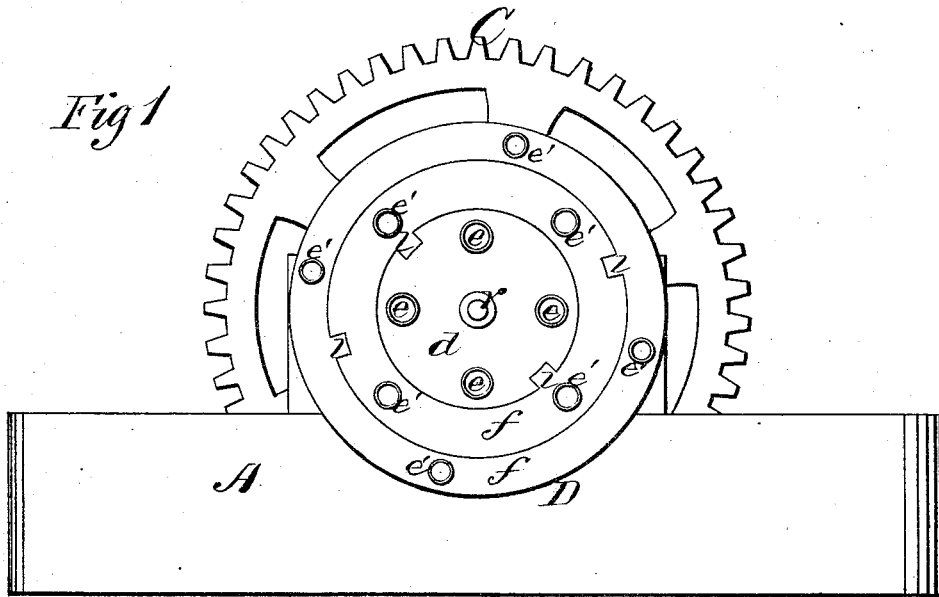

WITNESSES
Robert Cowitt,
Francis J. Chasie

INVENTOR
Calvin B. Davis,
Chipman & Co.

ATTORNEYS

UNITED STATES PATENT OFFICE.

CALVIN B. DAVIS, OF CASSADAGA, NEW YORK.

IMPROVEMENT IN LATHE-DOGS.

Specification forming part of Letters Patent No. 163,640, dated May 25, 1875; application filed May 1, 1875.

To all whom it may concern:

Be it known that I, CALVIN B. DAVIS, of Cassadaga, in the county of Chautauqua and State of New York, have invented a new and valuable Improvement in Lathe-Dogs; and I do hereby declare that the following is a full, clear, and exact description of the construction and operation of the same, reference being had to the annexed drawings, making a part of this specification, and to the letters and figures of reference marked thereon.

Figure 1 of the drawings is a representation of a side view of my device, and Fig. 2 is an end view of the same.

This invention has relation to improvements in veneer-cutting-machine or lathe dogs.

The object of the invention is to provide a means whereby very large logs may be rigidly held in proper position to a veneer-cutter for causing the sheets of stuff to be cut off of even and unvarying thickness, and also a means whereby the dog may decrease in diameter to accommodate itself to the constantly-lessening diameter of the log.

To this end the nature of the invention consists in a number of concentric, detachable, adjustable studded rings, adapted to be secured together against rotation independently of each other and of a central disk, upon which they are applied, as will be hereinafter more fully explained.

In the annexed drawings, A designates a frame affording bearings for the shaft B, which carries upon one end a gear-wheel, C, and upon the other a circular dog, D. This dog consists of a central disk, *d*, of circular form, which is keyed to, or otherwise secured against rotation on, shaft B, and is provided with projecting tubular spurs *e*, and of one or more concentric and detachable rings, *f*, which, like disk *d*, are also provided with tubular spurs *e'*, arranged at a certain distance apart all around them. These rings are locked against rotation independently of each other and of the disk by means of radial lugs *l* on the said rings, which are adapted to be received in corresponding notches or recesses in the disk and rings, as shown in Fig. 1; but

while they are incapable of independent rotation they can be detached from each other and allowed to hang from the shaft, as shown in dotted lines, Fig. 2, free from the disk and its remaining rings, for the purpose of reducing the diameter of the dog, under circumstances hereinafter explained. A log having been placed in position, spurs *e e'* on the disk and rings are driven into its end, the weight of the log being supported by a rod, *r*, projecting centrally from disk *d* at one end, and by the usual well-known adjustable center at the other. Hence, when power is applied to gear-wheel C, causing it to rotate, a rotatory movement will be imparted to the log, causing it to present fresh surfaces to the cutting-knife, and holding it rigidly against displacement. By this means the strips of veneer will be taken off from the periphery of the log evenly and of equal thickness, and when it has been so reduced that the edge of the cutting-knife is likely to encroach upon the periphery of the outer ring *f*, it is detached from the log, and from the disk, and remaining rings, and thrust back, when, falling backward, it will hang from shaft B, in the position shown in Fig. 2 in dotted lines. As the log is reduced in size the next ring will be removed, and so on until the log is no longer capable of being cut into veneer, when it will be removed to make room for another. By this means a hollow log, or one which is rotten at heart, but sound outside, may be firmly held in place while the valuable portion is cut off.

What I claim as new, and desire to secure by Letters Patent, is—

In a lathe-dog, the concentric and detachable spurred rings *f*, adapted to be locked against rotation independently of each other, and of a central spurred disk, substantially as specified.

In testimony that I claim the above I have hereunto subscribed my name in the presence of two witnesses.

CALVIN B. DAVIS.

Witnesses:

JAMES M. BEEBE,
FRED. A. CLELAND.