

I. MALLERY. Water-Wheel.

No. 163,672.

Patented May 25, 1875.

Fig. 1

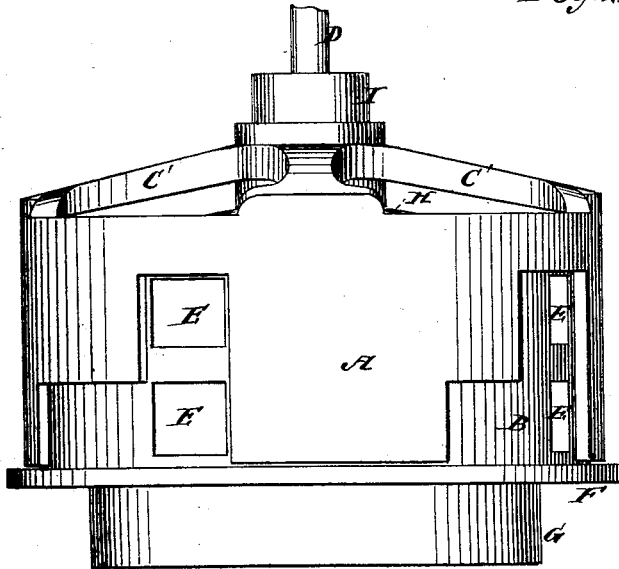

Fig. 2

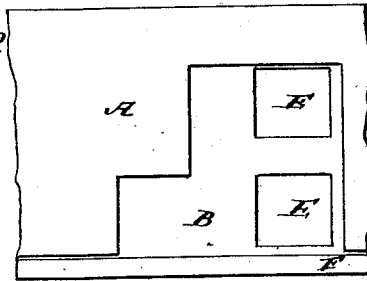

Fig. 3

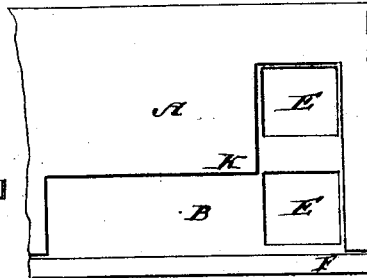

Fig. 4

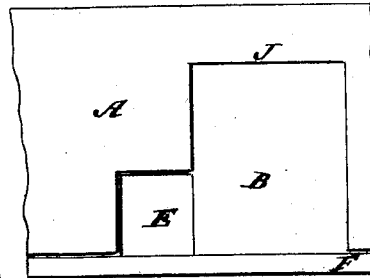

Fig. 5

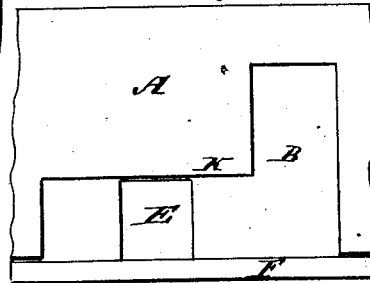
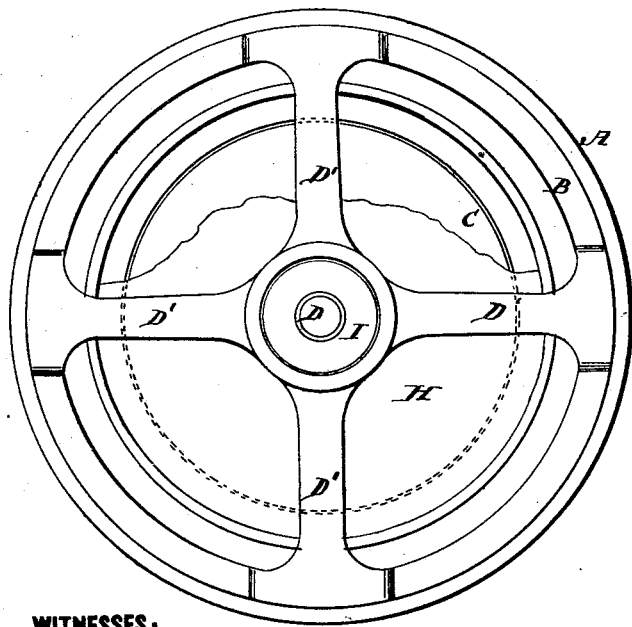

Fig. 6



WITNESSES:

E. Wolff
Alex. F. Roberts

INVENTOR:

Isaac Mallery
BY *Murray*
ATTORNEYS.

I. MALLERY.
Water-Wheel.

No. 163,672.

Patented May 25, 1875.

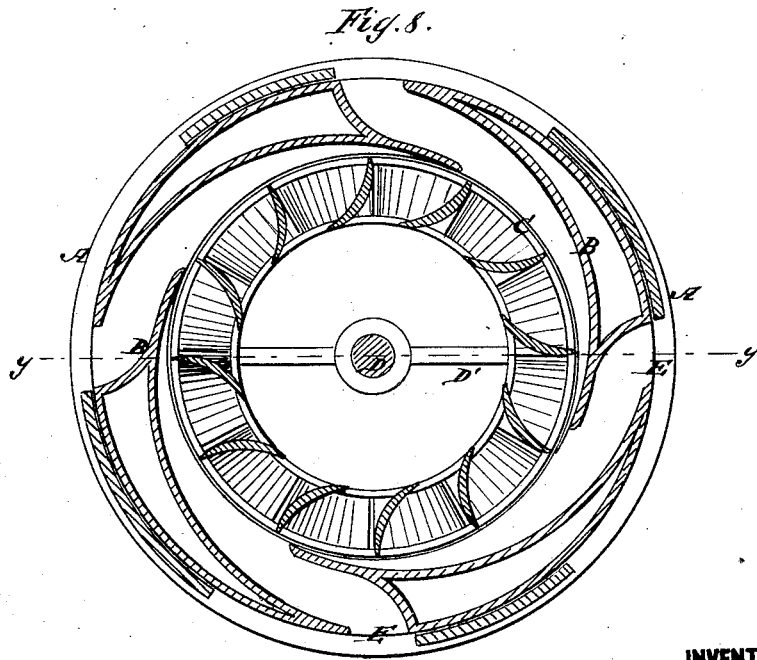
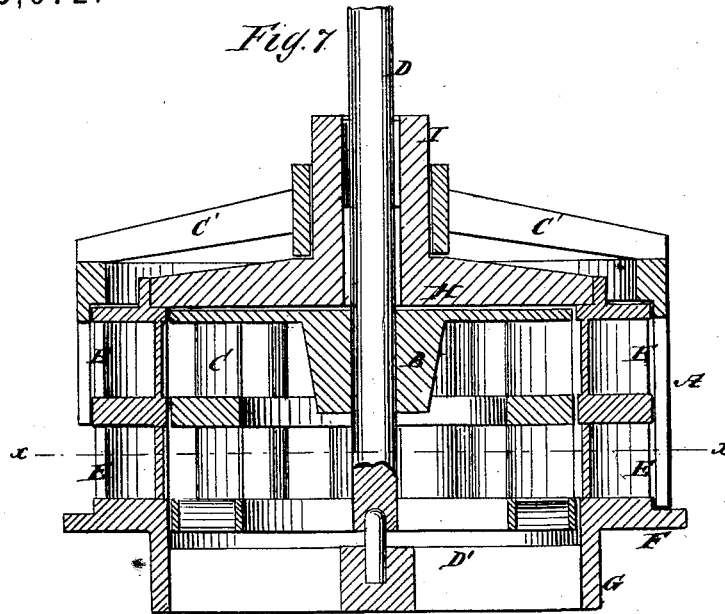

WITNESSES:
E. Wolff.
Alex. F. Roberts

INVENTOR:
Isaac Mallery
BY *[Signature]*
ATTORNEYS.

UNITED STATES PATENT OFFICE.

ISAAC MALLERY, OF DRYDEN, NEW YORK.

IMPROVEMENT IN WATER-WHEELS.

Specification forming part of Letters Patent No. **163,672**, dated May 25, 1875; application filed March 13, 1875.

To all whom it may concern:

Be it known that I, ISAAC MALLERY, of Dryden, in the county of Tompkins and State of New York, have invented a new and useful Improvement in Water-Wheels, of which the following is a specification:

The present invention consists in certain improvements in turbine water-wheels, which will be hereinafter, and subsequently, pointed out in the claim.

In the accompanying drawing, Figure 1 represents a side view of the improved water-wheel. Fig. 2 is a sectional view of the gate, which is in the form of a cylinder, having openings therein, through which the water is admitted to the chutes, and is discharged on to the buckets of the wheel. Fig. 3 is another section of the gate. Fig. 4 is another section or part of the gate, and Fig. 5 is another portion. In these views the four opposite sides of the gate are shown, the opposite openings thereof being of different size and shape. Fig. 6 is a top view of the wheel and chute-curb, showing also the gate and the arms or spider thereof and the central hole for the water-wheel shaft. Fig. 7, Sheet 2, is a horizontal section of the wheel, taken on the line *xx* of Fig. 8. Fig. 8 is a vertical section of the wheel, taken on the line *yy* of Fig. 7.

Similar letters of reference indicate corresponding parts.

A represents the gate, which surrounds the chute-curb B. C is the wheel, and D the shaft thereof, the lower end of which revolves on a center on the bridge-tree D'. C' are the arms of the gate. E represents the chutes which conduct the water to the buckets of the wheel. The chute-curb B is stationary, and rests on the bottom of the flume on the flange F, an opening being made for the wheel of the diameter of the flange G, which flange supports the bridge-tree D' of the wheel-shaft. The gate is supported on the disk H, which disk covers the wheel, the hub I of which disk forms the bearing of the shaft. Through the four opposite sides of the chute-curb are one or more of the openings E, which conduct the water to the tiers of the buckets in the wheel.

The gate is made with openings J J on opposite sides, and K K opposite each other. These openings in the gate are so arranged in regard to the chute-openings that the water may be entirely shut off; or two or more of the chute-openings may be uncovered; or one or more for each of the two openings in the gate, as seen in Figs. 2 and 3 and 4 and 5, Sheet 1. These openings are made on the opposite sides of the wheel, so that the wheel will be balanced by the water thus admitted.

It will be seen that the water may be admitted to only the lower tier of buckets in the wheel through two or four openings, E; or, by moving the gate farther, two or four chute-openings are uncovered for the upper tier of buckets, so that water may be admitted through two, four, six, or eight openings, successively, according to the amount of power required.

The wheel may be made with more than two tiers of buckets, and the capacity be thus increased.

This manner of admitting the water to the wheel is the main feature of my invention, the gate being turned or operated by means of cog and pinion, revolved by a shaft, preferably a vertical shaft, with cogs on the outside of the gate.

In Fig. 8, Sheet 2, directly beneath the lower tier of buckets in the water-wheel, is a tier of reaction-buckets, into which the water from the other buckets enters, and discharges from the bottom of the wheel, thus utilizing the water after it has left the direct-action buckets.

Having thus described my invention, I claim as new and desire to secure by Letters Patent—

In combination with a turbine-wheel, C, having two sets or tiers of buckets, arranged one above the other, and a chute-curb, B, having two tiers of chutes, E, the revolving gate A, provided with a series of openings, J J and K K, all constructed and relatively arranged as herein shown and described.

ISAAC MALLERY.

Witnesses:

T. B. MOSHER,
ALEX. F. ROBERTS.