

P. BALL & B. FITTS.

Pressure-Regulator with Dash-Pot.

No. 163,721.

Patented May 25, 1875.

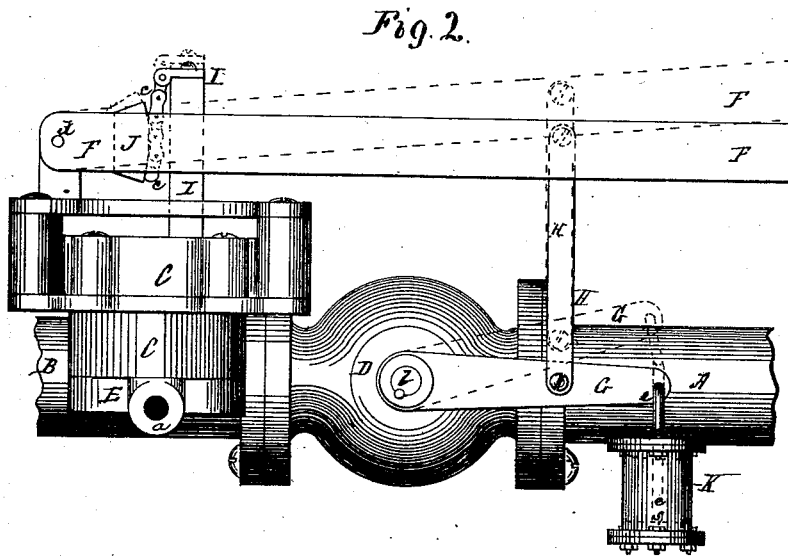
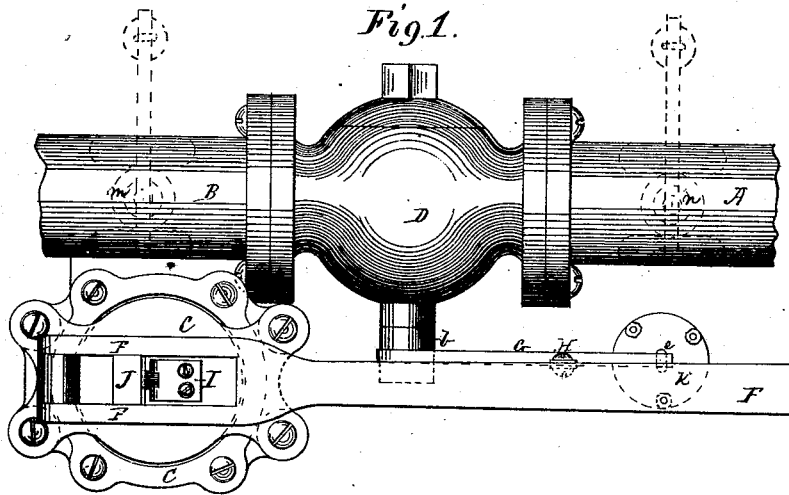

Witnesses,  
F. S. Kern  
D. G. Stuart

Inventors,  
Phineas Ball & Benajah Fitts  
per  
P. H. Dunay atty.

# UNITED STATES PATENT OFFICE.

PHINEHAS BALL AND BENAIHA FITTS, OF WORCESTER, MASS., ASSIGNORS  
TO THE UNION WATER-METER COMPANY, OF SAME PLACE.

## IMPROVEMENT IN PRESSURE-REGULATORS WITH DASH-POTS.

Specification forming part of Letters Patent No. **163,721**, dated May 25, 1875; application filed  
March 15, 1875.

*To all whom it may concern:*

Be it known that we, PHINEHAS BALL and BENAIHA FITTS, of Worcester, in the county of Worcester and State of Massachusetts, have invented certain new and useful Improvements in Pressure-Regulators with Dash-Pots; and we do hereby declare that the following is a full, clear, and exact description thereof, which will enable others skilled in the art to which it pertains to make and use the same, reference being had to the accompanying drawings and to the letters of reference marked thereon, which form a part of this specification, in which—

Figure 1 represents a plan of a water-main having our improvements applied thereto, and Fig. 2 a side elevation of the same.

Our improvements relate to that class of water-mains provided with pressure-regulators, for reducing the pressure in the low service-mains; and has for its object the prevention of accidents to the mains from that reaction of the water—technically called a water-hammer. These accidents principally arise from a too sudden closing of the main or governor valve by the reaction of the water on the operative piston or diaphragm of the regulator. This reactionary blow of the so-called water-hammer is frequently so quick and hard as to instantly close the valve. It is, therefore, advisable and desirable, in order to avoid this dangerous evil, that the regulator should be caused to act on the main valve with as gradual and uniform a motion as is consistent with the nature of the force exerted. Our improvement, for the purpose of remedying this trouble, consists in combining, with a regulator applied to a water-main, a dash-pot, so attached to the operative-lever of the former, and to the main valve, as to retard without stopping the motion of either, thereby preventing the instantaneous closing of the valve.

To enable others skilled in the art to make, construct, and use our invention, we will now describe its parts and their relation to each other in detail, omitting a particular description of such parts of a water-main and pressure-regulator as are not essential to a full understanding of our present improvement.

The water-main and pressure-regulator may be of any suitable construction, and may be connected together, and with the main or governor valve, in any suitable or known manner, the peculiar construction of either forming no part of our present improvement.

In the drawings are shown a suitable construction, arrangement, and combination of high and low service-mains, pressure-regulator, and governor-valve for the purposes of this invention, the high service-main A and low service-main B being respectively attached or secured to the opposite ends of the shell or chamber of valve D. The pressure-regulator C is represented as being so connected in the low service-main B as to communicate with the interior of the latter from the under side of its own piston through a communicating-channel, *a*, (shown in dotted lines, Fig. 1,) formed in a bed-plate, E, cast on the side of the first section B of the low service-main, and which bed-plate forms the support of the regulator, the latter being securely bolted thereto.

The regulator for the purposes of our improvement should be of that variety or class which is provided with a lever, F, through which to operate the governor-valve D. The stem *b* of the valve for this purpose is provided with an arm or crank lever, G, which is connected to lever F by a link-rod or lever, H. Lever F may be operated either directly from its under side by the action of the piston-rod I of the regulator, or indirectly, as shown in the drawing, by attaching one end of a chain, *c*, to the upper end of rod I, and the other to a cross-piece, J, made fast to lever F between the bifurcations of its pivoted end. The cross-piece J should be arranged a short distance in advance of the pivot or fulcrum pin *d* of said lever F, so as to give a long sweep to the lever for a short movement of the piston.

The main valve D, as thus connected with the lever F, it is apparent will be subject to all the movements of the piston I, whether great or small, quick or slow, and therefore subject to be instantaneously closed by any force sufficiently strong or quick to instantly raise the regulator-piston and its rod I to the full end of

its stroke, and thus create a reaction or water-hammer in the high service-main A. To prevent such an eventuality we apply to the outer end of arm G a dash-pot, K, and thus prevent the arm from moving any faster than the water or oil which it contains can flow around from the one side of the piston to the other. This retards the movement of the arm G and lever F, and thus prevents any sudden closing of the main valve D and its concomitant evils.

The dash-pot may be of the ordinary construction, such as a cylinder, K, filled with oil or water, and provided with a piston of a diameter less than the interior of the cylinder. The piston *s* carries a rod, *e*, the outer end of which is loosely connected to the end of lever G.

In order that the rod *e* may be allowed to conform to the curvilinear motion of the lever G, cylinder K, which forms the dash-pot, may be pivotally secured to a supporting-frame provided for the purpose; or the connection between lever G and rod *e* may be formed through the instrumentality of a link-rod or lever, the ends of which are, respectively, pivoted to the rod *e* and lever G, or in any other suitable and known manner.

Instead of connecting the dash-pot with the arm G of the valve, it may, if desired, be attached directly to the lever F of the regulator; but the former mode is preferred.

Under ordinary circumstances the simple combination of the dash-pot with the arm G will be sufficient for most emergencies, yet as there may be times when additional precautions may be desirable, it may then be used in connection with safety-valves *m* and *n*, (shown in dotted lines in Fig. 1,) applied, respectively, to the high and low service-mains, and which application is more particularly described in another application for Letters Patent filed herewith, but in which the valves are not claimed or shown in combination with a dash-pot, such claim being specially reserved for this application. As a rule, but one of these safety-valves would probably be re-

quired—that is to say, the valve *n*, shown in dotted lines, Fig. 1, as applied to the low service-main, where it is specially designed to counteract the reactionary effects of a water-hammer on the low service-main; but the other we prefer to use also, in order to reap the benefit of its ordinary use as a safety-valve, and also in cases of strong emergency for the purposes of neutralizing the possible occurrence of a water-hammer in the high service-main.

These safety-valves may be of any known and suitable variety adapted to the purpose, each being respectively loaded to suit the different pressures in the high and low service-mains to which they are applied.

Having described our invention, we claim—

1. The combination of a pressure-regulator, C, and dash-pot K with a water-main and its governor-valve D, substantially as and for the purpose set forth.

2. The combination of a pressure-regulator, C, dash-pot K, and safety-valve *m*, with a water-main and its governor-valve D, safety-valve *m* being applied to the low-service end B of said main, substantially as and for the purposes set forth.

3. The combination of a pressure-regulator, dash-pot, and safety-valve *n*, with a water-main and its governor-valve, safety-valve *n* being applied to the high-service end A of said main, substantially as and for the purposes set forth.

4. The combination of a pressure-regulator, dash-pot, and two safety-valves, *m* and *n*, with a water-main and its governor-valve, the whole being arranged in the manner and for the purposes substantially as set forth.

In testimony that we claim the foregoing as our own we have affixed our signatures in presence of two witnesses.

PHINEHAS BALL.  
BENALIAH FITTS.

Witnesses:

ABIEL E. WILSON,  
S. AUGUSTUS WELCH.