

E. GRAH.
Permutation-Lock.

No. 163,767.

Patented May 25, 1875.

Fig. 1.

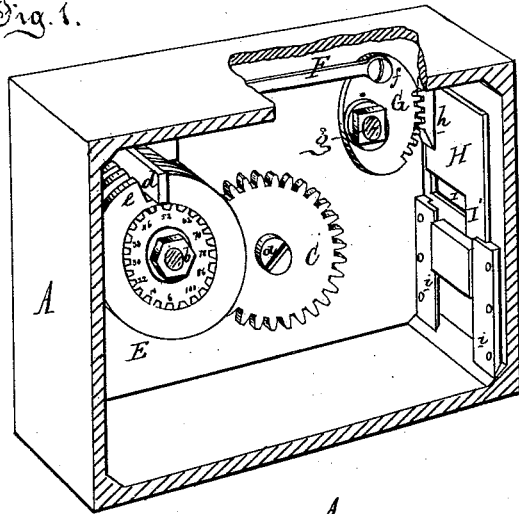

Fig. 6.

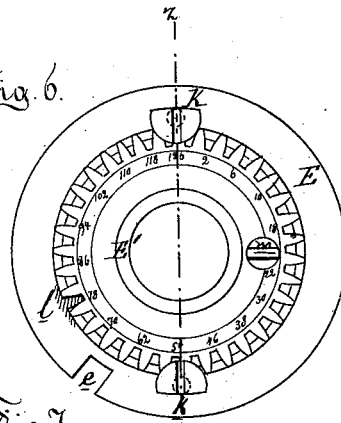

Fig. 7.

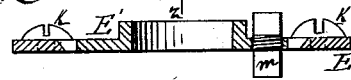

Fig. 2.

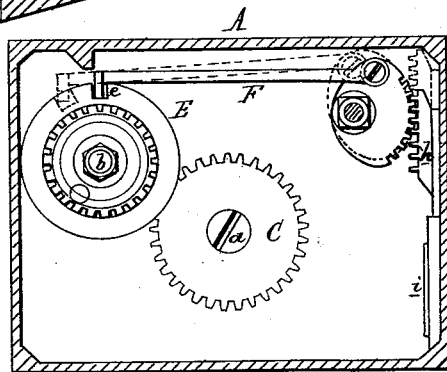

Fig. 4.

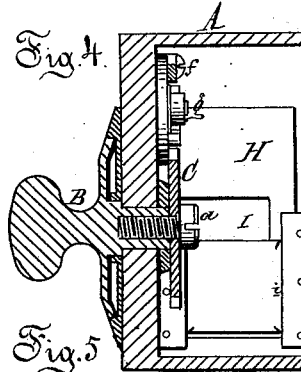

Fig. 3.

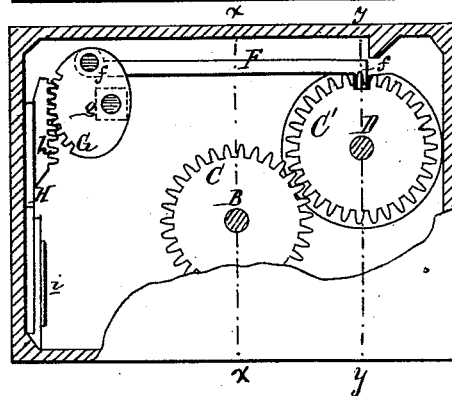
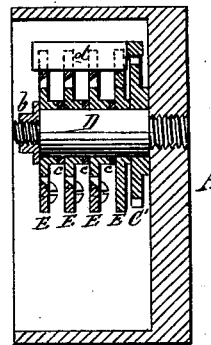

Fig. 5.



Attest:
Edward Parthel.
E. P. Parthel

Inventor:
E. Grah
By Atty
Wm. S. Sprague

UNITED STATES PATENT OFFICE.

EMIL GRAH, OF TOLEDO, OHIO.

IMPROVEMENT IN PERMUTATION-LOCKS.

Specification forming part of Letters Patent No. **163,767**, dated May 25, 1875; application filed April 6, 1875.

To all whom it may concern:

Be it known that I, EMIL GRAH, of Toledo, in the county of Lucas and State of Ohio, have invented certain Improvements in Permutation-Locks, of which the following is a specification:

The nature of my invention relates to certain improvements in permutation or combination locks, such as are used in safe and vault doors; and my invention therein consists in the several details of construction, as more fully hereinafter described and claimed.

Figure 1 is a perspective view of my lock from the rear, showing the dog in the act of raising the slide-stop to permit the bolt to be thrown. Fig. 2 is a rear elevation, showing the slide-stop down, and in dotted outline raised. Fig. 3 is a sectional front elevation, showing the gearing through which the dial-spindle actuates the change-wheel. Fig. 4 is a cross-section through the dial-spindle at *x x*. Fig. 5 is a similar section through the change-wheels at *y y*. Fig. 6 is an elevation of a changeable tumbler-wheel, showing the side next the front of case. Fig. 7 is a cross-section of the same at *z z*, showing the stud or pin, which on one side strikes the pin of the next wheel on the spindle, and on the other side to be actuated by the preceding wheel.

In the drawing, A represents the case of the lock, through the front plate of which is journaled the spindle of a dial-knob, B. To the inner end of the spindle a spur-wheel, C, is secured by a cap-screw, *a*. D is a spindle-stud, tapped from the back into the front plate of the lock-case, and on it is sleeved a spur-wheel, C', next to the front end. On the same spindle-stud the tumbler-wheels E are also sleeved, secured in place by a nut, *b*, on the end of the stud. A washer, *c*, Fig. 5, is interposed between each pair of wheels E. The wheels C and C' are of equal diameter, and are geared together, so that motion is given to the latter by rotating the knob. The tumbler-wheel E next the spur-gear *c'* is keyed fast to the said gear, and moves with it, so that its number or unlocking position on the dial is unchangeable. Each wheel E has a notch, *e*, cut in its periphery, into which, when all said notches are brought in line, may drop a fence-dog, *d*, bent at a right angle in the end of a bar, F, whose other

end is pivoted by a wrist-pin, *f*, to a geared sector, G, pivoted to a stud, *g*, near the front of the lock-case, which sector meshes with a toothed rack, *h*, on the back of a sliding plate or bolt, H, moving in guides *i* in the front end of said lock-case, in which one or more holes, I, are cut to receive the horizontal shank of the vertical bar, which carries the side-bolts of the door. (Not shown.) A corresponding opening or openings, I', are cut in the slide H, which, when raised by the engagement of the dog with the combination-wheels, and turning them to the right to partially rotate the geared sector, will bring the openings I' opposite the opening I, and thus permit the bolt to be thrown by its knob or spindle, the bolt-shank passing through the openings I I'. When the dog is out of the notches the slide is down, covering the opening I, so that the shank cannot pass through them; neither can the combination be picked up by "feeling," or with a micrometer. The sliding bolt H may extend through the lock-case from near the top to near the bottom of the door, so that the vertical bar of the bolt-work may carry any desired number of stop-shanks, to frustrate the burglar who drills the door to break off one of them, usually placed at the end of the lock-case. Neither is it necessary to invariably locate the combination-wheel at any particular point, nor within a given radius of the knob-spindle, as that is the weak spot and defect in all combination dial-locks now in use, for the skillful burglar has to drill but a single small hole at or nearly opposite the periphery of the tumblers in the front plate of the door and lock-case, in order to see the notches in the tumbler-wheels as they are successively brought into line, and thus pick up the combination. The adjustable tumbler-wheels are each made in two parts—an outer ring, E, having an internal flange or counter-bore, and a toothed disk, E', which is inserted in it, resting on the internal flange, and secured by two half-headed screws, *k*, tapped in said ring and turned over the periphery of said disk. The rim E has a single internal tooth, *l*, which is received between two teeth of the disk, all of which, or any proportion thereof, may have numbers stamped at their roots or between them. The number opposite the tooth *l* indicates the unlocking number on the dial

for that tumbler-wheel, and it will be seen that the combination of the lock can quickly be changed by simply taking off one or more tumbler-wheels and shifting their disks in the rims before replacing them on the stud. The tumbler-wheels are successively rotated by a pin, *m*, projecting from the disk of each, which strikes a similar pin on the adjacent one.

What I claim as my invention, and desire to secure by Letters Patent, is—

1. The combination of the toothed disk *E'* with the rim *E*, provided with the single tooth

l, notch *e*, and screws *k*, substantially as and for the purpose set forth.

2. The combination, with the dial-knob *B* and gear-wheel *C*, of the spindle *D*, carrying the tumblers *E*, provided with the notches *e*, and gear-wheel *C'*, bar *F*, dog *d*, geared sector *G*, and rack-bolt *H*, all constructed and arranged substantially as described and shown.

EMIL GRAH.

Witnesses:

JAMES WOOD,
W. H. GANSS.