

C. W. HERMANCE.

\* Reciprocating Steam-Engine.

No. 163,773.

Patented May 25, 1875.

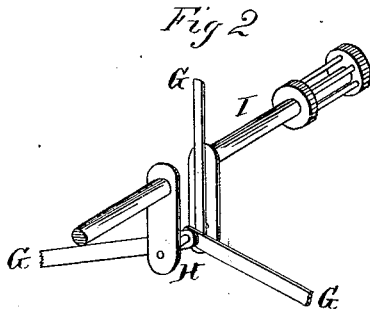
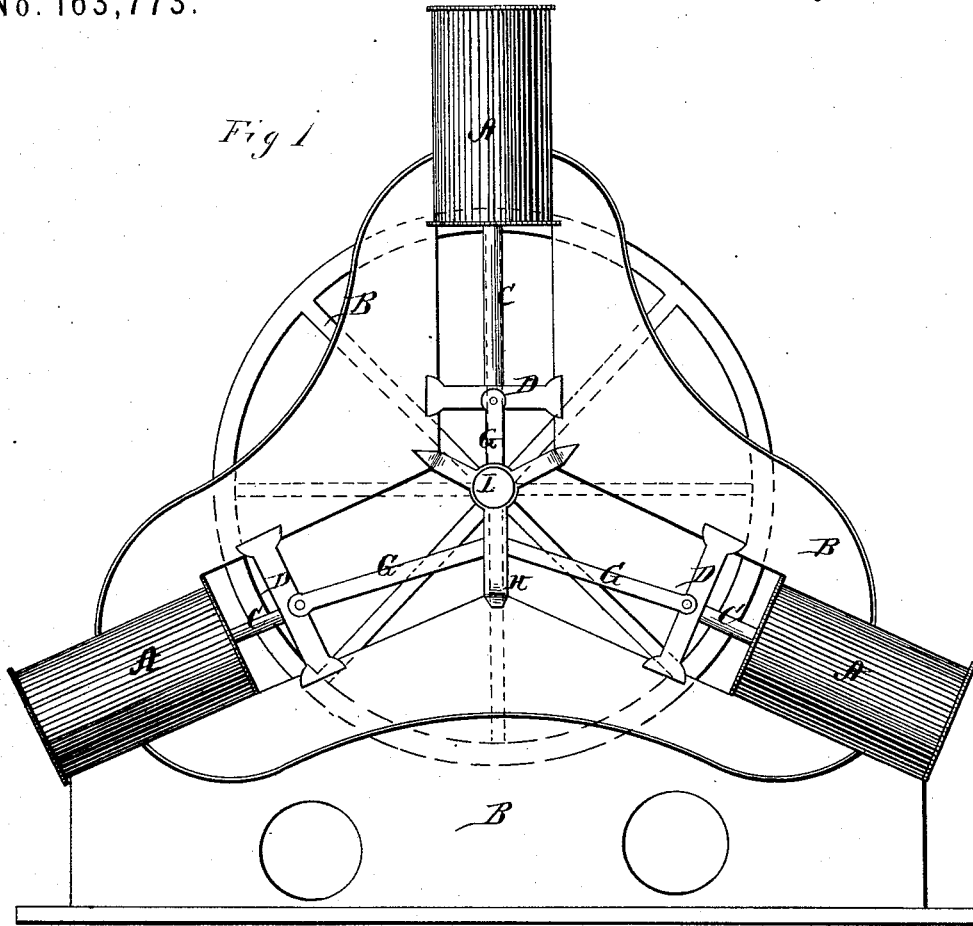

Witness:  
Frank L. Durand  
L. L. Ewert

Inventor.  
Chas. W. Hermance  
per Abraham M. Mason

Attorneys.

# UNITED STATES PATENT OFFICE.

LYDIA W. HERMANCE AND J. D. MOTT, OF MOSES KILL, NEW YORK,  
ADMINISTRATORS OF CHARLES W. HERMANCE, DECEASED.

## IMPROVEMENT IN RECIPROCATING STEAM-ENGINES.

Specification forming part of Letters Patent No. **163,773**, dated May 25, 1875; application filed  
May 6, 1875.

*To all whom it may concern:*

Be it known that I, CHAS. W. HERMANCE, of Schuylerville, in the county of Saratoga and in the State of New York, have invented certain new and useful Improvements in Steam-Engines; and do hereby declare that the following is a full, clear, and exact description thereof, reference being had to the accompanying drawings and to the letters of reference marked thereon, making a part of this specification.

The nature of my invention consists in the construction of a steam-engine having an odd number, three or more, stationary cylinders arranged around a crank-shaft at equal distances from each other, in such a manner that the full pressure upon two pistons will be constantly exerted upon the crank at the same time, for by this combination only one piston can pass a dead-center at a time.

In order to enable others skilled in the art to which my invention appertains to make and use the same, I will now proceed to describe its construction and operation, referring to the annexed drawings, in which—

Figure 1 is a front elevation of my engine, and Fig. 2 is a perspective view of the crank with the three connecting-rods.

A A A represent three stationary cylinders, arranged on a suitable frame, B, at equal distances apart—that is, at an angle of one hundred and twenty degrees from each other. C C C are the piston-rods of the cylinders A, each rod attached to a cross-head, D, sliding upon suitable ways or guides. The three cross-heads D are each, by a rod, G, connected with the crank H on the shaft I.

The advantages derived from this combination and arrangement of the cylinders are, in part, as follows: Greater power is obtained from equal boiler-pressure and area of piston than can be derived from engines of other construction. For example, in a double en-

gine with sixty inches area of piston, one is constantly passing on the center as the other is passing off, giving only the constant effective power of one cylinder, or thirty inches area of piston, with the three-cylinder engine with twenty inches area of piston in each cylinder, the same steam-surface as in the double engine of sixty inches area; but as there can only be one piston on the center at a time, only one-third of the power in this case as against one-half in the other is lost in passing centers, and ten inches area of piston under work is constantly gained. Another advantage of this arrangement of the cylinders is the increased velocity at which this engine can be safely run by reason of the steady motion imparted to the crank-shaft, and as power increases either by increasing the pressure of steam or speed of the piston fully twenty-five per cent. is gained by this engine over others of different construction with the same pressure and area of piston.

More than three stationary cylinders may be used to operate on one shaft; but whatever odd number may be used they should be arranged at equal distances apart around the crank-shaft.

Having thus fully described my invention, what I claim as new, and desire to secure by Letters Patent, is—

The combination of the frame B, equidistant cylinders A A A, piston-rods C C C, cross-heads D D D, connecting-rods G G G, crank H, and shaft I, all constructed to operate substantially as and for the purposes herein set forth.

In testimony that I claim the foregoing I have hereunto set my hand and seal this 11th day of January, 1875.

CHAS. W. HERMANCE. [L. S.]

Witnesses:

S. WELLS,  
SAML. SHELDON.