

F. H. HUNTER.
Burglar-Alarm.

No. 163,779.

Patented May 25, 1875.

Fig: 1.

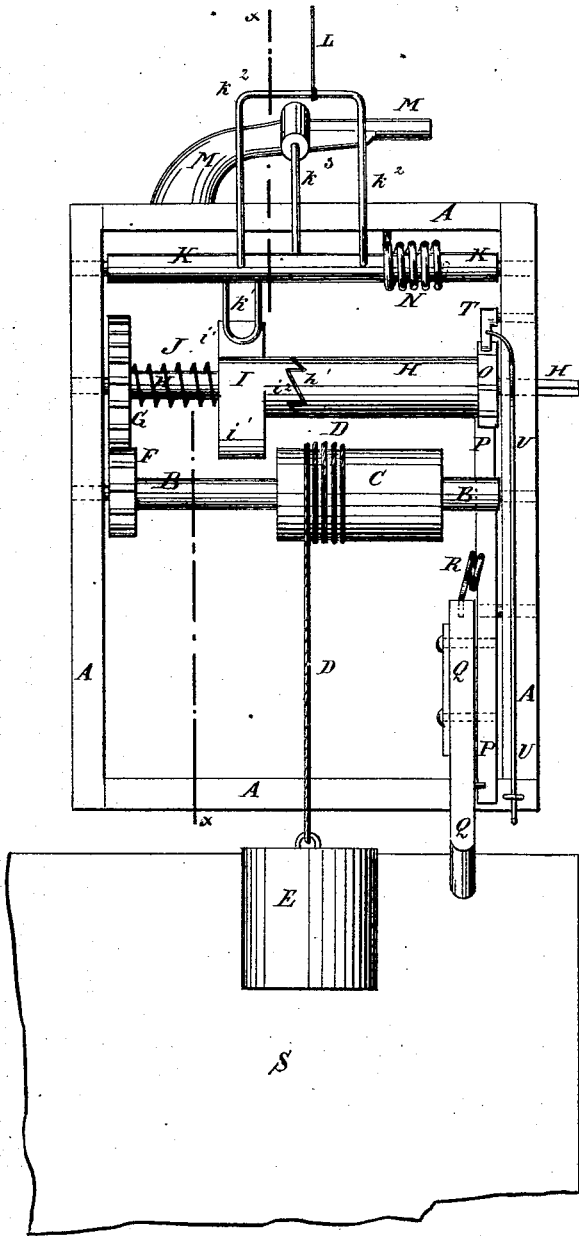
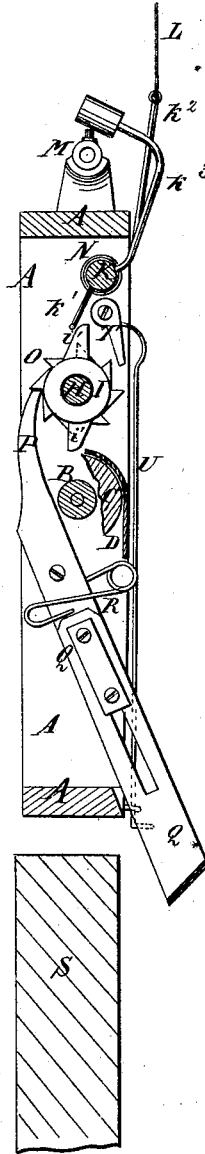

Fig: 2.



WITNESSES:

Chas. Rice
A. J. Terry

INVENTOR:

F. H. Hunter
BY *Munroe*

ATTORNEYS.

UNITED STATES PATENT OFFICE.

FRELINGHUYSON H. HUNTER, OF HELTONVILLE, INDIANA.

IMPROVEMENT IN BURGLAR-ALARMS.

Specification forming part of Letters Patent No. **163,779**, dated May 25, 1875; application filed April 3, 1875.

To all whom it may concern:

Be it known that I, FRELINGHUYSON H. HUNTER, of Heltonville, in the county of Lawrence and State of Indiana, have invented a new and useful Improvement in Burglar-Alarm, of which the following is a specification:

Figure 1 is a front view of my improved burglar-alarm. Fig. 2 is a vertical section of the same, taken through the line *x x*, Fig. 1.

Similar letters of reference indicate corresponding parts.

The object of this invention is to furnish an improved device which, when connected with a door, will sound an alarm whenever the door is opened, and which shall be simple in construction and reliable in use.

The invention consists in the combination of the frame, the shaft, the drum, the cord and weight, the gear-wheels, the armed collar and its clutch and spring, and the shaft, provided with rigid arms, and a spring, to enable a pistol to be discharged, a drum to be sounded, and a bell rung by the descent of a weight; in the combination of a lever-pawl, provided with a sliding arm and a spring, with the ratchet-wheel attached to the shaft of the alarm.

A represents a small rectangular frame, which is designed to be attached to a wall or door-casing a little above the door. To the middle parts of the side bars of the frame A are pivoted the ends of a shaft, B, to which is attached a drum, C. To the drum C is attached one end of a rope, D, to the other or free end of which is attached a weight, E, sufficient to give motion to the apparatus. To one end of the shaft B is attached a gear-wheel, F, the teeth of which mesh into the teeth of a gear-wheel, G, attached to the end of a shaft, H, placed above the shaft B, and also pivoted to the side bars of the frame A. Upon the shaft H is placed a collar, I, having arms *i*¹ projecting from its opposite sides, and having clutch-teeth *i*² formed upon one side to take hold of clutch-teeth *h*¹ formed upon a shoulder or collar formed upon or attached to the said shaft H. The collar I is held against the clutch-teeth *h*¹ by a spring, J, placed upon the shaft H, as shown in Fig. 1. To the side bars of the frame A, above the shaft H, is pivoted a shaft, K, to

the lower side of which is rigidly attached a downwardly-projecting arm, *k*¹, against which the arms *i*¹ of the collar I strike as the said collar is carried around by the shaft H. To the shaft K is attached an upwardly-projecting arm, *k*², to which is attached the end of the bell-wire L, so that the bell may be sounded by the movement of the shaft K. The bell may be placed in any desired part of the house. With the top bar of the frame A is connected a pistol, M, which is designed to be connected with the shaft K, or with one of its arms, so that it may be discharged by the movement of said shaft K. To the shaft K is also attached a hammer-arm, *k*³, which may be used to discharge the pistol M, or to strike a drum or gong. N is a spring, coiled around the shaft K, and one end of which is connected with said shaft, and its other end is connected with the frame A, so as to bring the said shaft K back to its position, when the arm *k*¹ slips off the arm *i*¹ of the collar I. One end of the shaft H projects and is squared off to receive the key by which it is turned to wind up the cord D of the weight E, the clutch-teeth *h*¹ *i*² allowing the shaft to be turned in this direction without sounding an alarm. To the end of the shaft H is attached a ratchet-wheel, O, upon the teeth of which rests the engaging end of the lever-pawl P, which is pivoted to the frame A. With the lower part of the lever-pawl P is connected a sliding arm, Q, which is held down by a spring, R, attached to the said lever-pawl P, and which presses against the upper end of the said arm Q. The lower end of the arm Q projects so that it may be struck by the door S as it is opened to withdraw the pawl P from the ratchet-wheel O, and allow the alarm to be set in motion by the weight E. The lower end of the arm Q is beveled off, so that when the door is closed the arm Q will be pushed up upon the pawl P without withdrawing the pawl P from the ratchet-wheel O, and without sounding an alarm. T is a pawl, pivoted to the side bar of the frame A in such a position that it may be lowered upon the teeth of the ratchet-wheel O to hold the said wheel, and thus allow the pawl P to be withdrawn from said ratchet-wheel by the opening of the door without sounding an alarm. To the pawl T is attached

a wire, U, which is so formed as, when left free, to hold the pawl T away from the ratchet-wheel O, and when drawn upon to draw the pawl T down upon the teeth of the ratchet-wheel O and lock the alarm.

Having thus described my invention, I claim as new and desire to secure by Letters Patent—

1. The combination of the frame A, shaft B, drum C, cord and weight D E, gear-wheels F G, armed collar I ⁱ, clutch ⁱ ^h, spring J, and the shaft K, provided with the arms ^k ^k ^k, and spring N, to enable a pistol to be discharged, a drum to be sounded, and a bell

rung by the descent of a weight, E, substantially as herein shown and described.

2. The pivoted lever-pawl and its sliding, slotted, extension piece or arm Q, and the spring R, in combination with the ratchet-wheel O of the alarm mechanism, and the frame A, having a fixed bottom bar for arresting the movement of the pawl, as shown and described.

FRELINGHUYSON H. HUNTER.

Witnesses:

ENOCH J. CUMMINGS,
FREEMAN S. HUNTER.