

G. B. LYMAN.
 Extension-Table Slide.

No. 163,792.

Patented May 25, 1875.

Fig. 1.

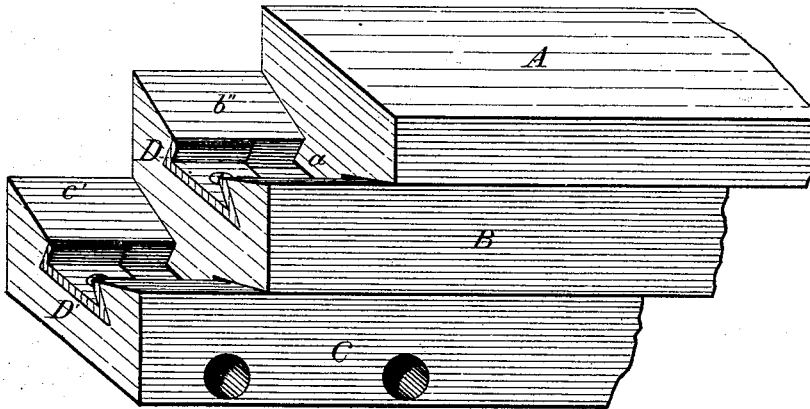

Fig. 2.

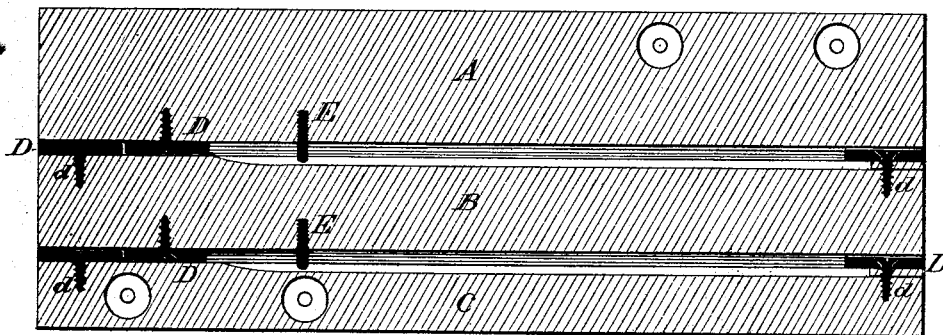
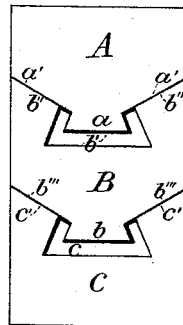

Fig. 3.



Attest.
Philip M. Pickle
 Philip M. Pickle

Inventor:
 George B. Lyman
 per L. Deane.
 his atty.

UNITED STATES PATENT OFFICE.

GEORGE B. LYMAN, OF DAYTON, OHIO.

IMPROVEMENT IN EXTENSION-TABLE SLIDES.

Specification forming part of Letters Patent No. **163,792**, dated May 25, 1875; application filed May 12, 1875.

To all whom it may concern:

Be it known that I, GEORGE B. LYMAN, of Dayton, in the county of Montgomery and State of Ohio, have invented certain new and useful Improvements in Table-Slide; and I do hereby declare that the following is a full, clear, and exact description thereof, which will enable others skilled in the art to which it pertains to make and use the same, reference being had to the accompanying drawings, and to the letters of reference marked thereon, which form a part of this specification.

Figure 1 is a perspective view. Fig. 2 is a central vertical section lengthwise. Fig. 3 is a central vertical section on a line at right angles to the foregoing.

This invention relates to an improvement in that class or kind of table-slides wherein the contiguous or bearing faces of the sliding bars are held in lateral contact while free to move longitudinally; and it consists more particularly in making the tongue or dovetail of the slide so much smaller than the groove in which it fits, and wherein it plays, that there shall always, and under any circumstance of heat or moisture, be a sufficient space between the faces of said tongue and groove to allow and permit easily the movements of the several bars of the slide, while at a suitable point on said tongue, and on each end of the groove, there is a narrow piece of metal or composition of such thickness and shape as to conform to, and nearly fill, the space between the said faces at these points.

By this means and method of construction there is afforded a device that cannot, under any ordinary circumstances of atmospheric change, get out of order, while it is very strong and durable, and easily made and put together, all as will now be more fully set forth and explained.

In the drawing, A, B, and C represent the bars of an ordinary extension-table slide in the usual arrangement for use. The top and bottom bar, respectively, on their lower and upper face have a tongue or dovetail, *a*, and lateral bearing-faces *a'*, or a groove, *c*, and lateral bearing-faces *c'*, conforming in shape and structure to the groove *b'*, and lateral bearing-faces *b''* of the inner bar on the one side, or the tongue or dovetail *b* and lateral bearing-

faces *b'''* of said bar on the other side. Thus the top and bottom bars may readily fit the one on the other, or any desirable number of intermediate bars may be interposed between. When so adjusted the peculiarly-shaped tongue or dovetail *a* or *b* will fit into the groove *b'* or *c*, which is of a corresponding shape or size.

Heretofore it has been customary or usual to so cut this tongue or dovetail and groove in the wood that the contiguous faces come closely in contact with each other; but it has been found in use that not infrequently a slide so made will stick or bind, and the several bars be held so firmly in place that they cannot readily be moved.

To overcome all this, I make the said tongue or dovetail and groove of such relative sizes that there is a small space between them on all their contiguous faces. To fill this space up at certain points, I provide at the ends of each groove a metal or composition plate, D, secured in position by a screw, *d*, or in any suitable way, and likewise on the face of each dovetail or tongue, and near one end a plate, D', of like shape and material, and similarly secured.

When the several bars are now placed together in the ordinary position for use, the said plates D and D' help constitute the bearing-surface on which the bars move as the slide is opened and closed. The movement of the slide in one direction is stopped by the contact of the ends of the plates D and D', and this may also occur at the other end in the opposite motion of the slide, or a stop, E, may be placed for that purpose at a suitable point in the tongue or dovetail.

The several bars are chiefly held firm and secure in place by means of the peculiarly-shaped angle-plates D D', as described, and will always play readily back and forth, the one on the other, because there is afforded no surfaces or points of contact where said bars can bind or stick, nor is there any serious friction between the faces of the angle-plates and the contiguous faces of the wood.

Having thus described my invention, what I consider new, and desire to secure by Letters Patent, is—

1. An extension-table slide, having a dovetail tenon with bearing-surfaces at each side,

adapted to slide in a mortise in the adjacent block with corresponding bearing-surfaces, said mortise being enlarged considerably beyond the size of the tenon, while at each end it is provided with a metallic plate closely fitting said tenon, the latter being also embraced by a similar plate, which serves as a stop, and also to guide the tenon in the enlarged mortise, substantially as and for the purposes set forth.

2. The slide A B, having the dovetail tenon

a and mortises *c*, respectively, the latter being enlarged, as described, and provided with the plates D and pins E, all constructed substantially as and for the purposes set forth.

In testimony that I claim the foregoing as my own I affix my signature in presence of two witnesses.

GEORGE B. LYMAN.

Witnesses:

JAMES LINDEN,
J. A. JORDAN.