

G. H. TIMMERMAN.  
Magazine Heating-Stove.

No. 163,824.

Patented May 25, 1875.

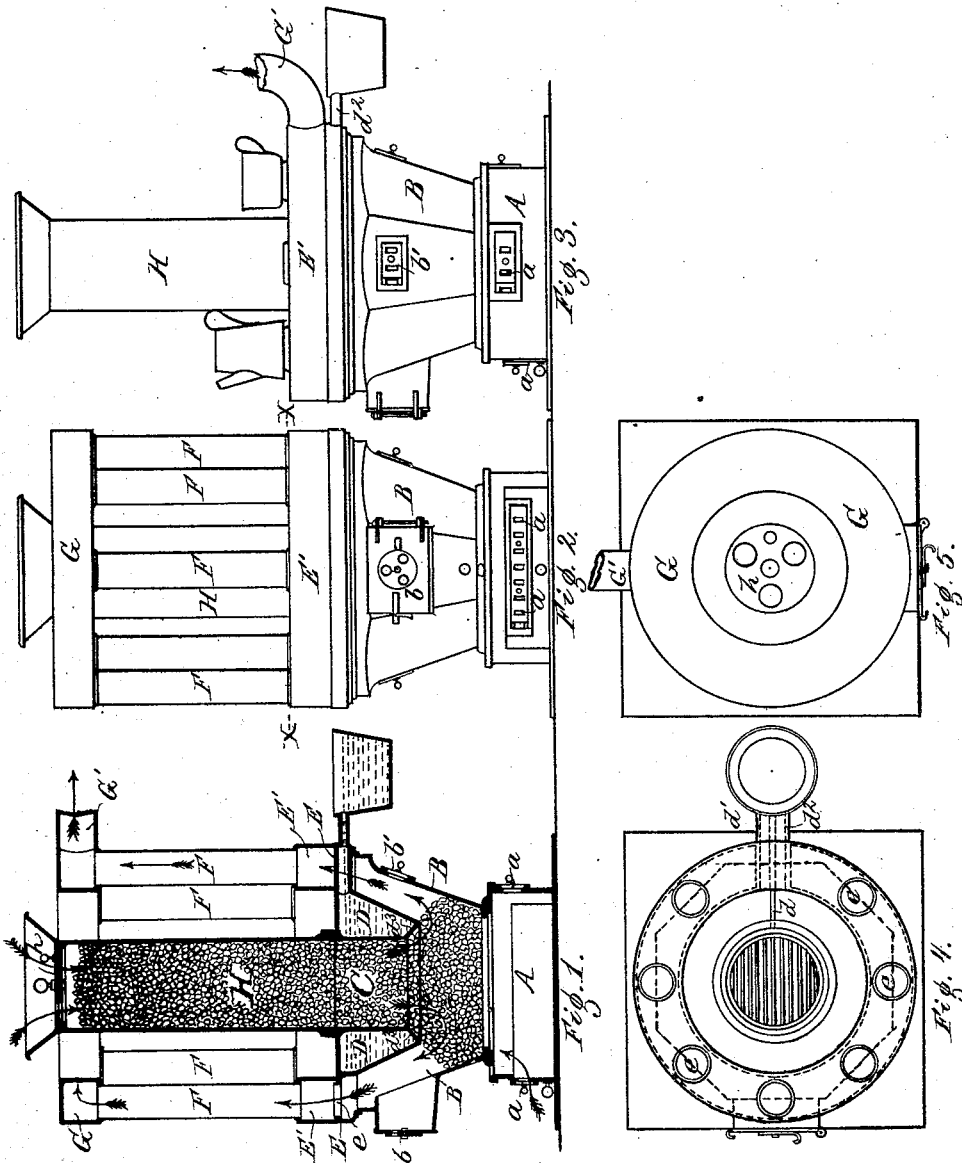

Witnesses:  
*Chas. D. Meisner*  
*J. W. Scuttel.*

Inventor:  
*Gerhard H. Timmerman*  
 per. *Hertub & Co*  
*attys.*

# UNITED STATES PATENT OFFICE.

GERHARD H. TIMMERMAN, OF ST. LOUIS, MISSOURI.

## IMPROVEMENT IN MAGAZINE HEATING-STOVES.

Specification forming part of Letters Patent No. **163,824**, dated May 25, 1875; application filed April 1, 1875.

*To all whom it may concern:*

Be it known that I, GERHARD H. TIMMERMAN, of St. Louis, Missouri, have invented an Improved Heating-Stove, of which the following is a specification:

The object of this invention is to form an improved stove that shall possess the advantages of being a smoke and gas consumer, shall be self-feeding, also ventilate a room by causing its foul air to enter the stove, have a greater surface for radiation of heat, and otherwise in its use afford cleanliness and a saving of time and labor.

Of the drawing, Figure 1 is a sectional elevation; Fig. 2, a front elevation; Fig. 3, a front elevation showing my stove adapted for kitchen or similar household purposes. Fig. 4 is a cross-section on line *xx* of Fig. 2. Fig. 5 is a top plan.

A is the base. This, on all sides, has slide-registers *a*. These control the register-openings, and by means thereof the cold air in the room is passed into the grate or stove. Top of the base A is the stove-body B, the door *b* of which is chiefly for purposes of cleaning the stove. The sides of the body B have similar sliding registers, *b'*, (see figures,) to those of *a*, in order to properly control the draft. Top of the main body B is my improved stove part, consisting of the parts all cast in one piece, viz., the lower extension part C of the feed-pipe, surrounding this a chamber, D, also top plate E, all clearly shown in Fig. 1. Through the feed part C the coal or fuel is fed. The chamber D is a water-chamber; as such it is divided by a partition, *d*. (See Fig. 4.) The water enters, through a pipe, *d*<sup>1</sup>, the chamber on one side of its partition, while on the opposite side of same the efflux of water is through the pipe *d*<sup>2</sup>, into a proper receptacle. (Shown in dotted lines, Fig. 4.) By this means hot water can be had for service, or used for moistening the atmosphere in a room; also, said water-chamber protects the metal from the action of the heat. At the bottom of the chamber D (or feed-pipe C) the smoke, gases, &c., are made to pass through the fire, and thus be consumed. For this purpose the bottom at *d*<sup>3</sup> flares outwardly, (see Fig. 1,) forming a greater surface for the smoke, &c., to pass over, and consequently be longer

in or subjected to the fire. The top plate E has a number of flue-passages, *e*, (see Fig. 1,) each communicating with a flue-chamber, E'. (See Fig. 1.) F, Figs. 1 and 2, are the flue-pipes. All these pipes further communicate with a top flue-chamber, G. G' is the stove-pipe, for carrying off the products of combustion. H is the feed-pipe, for self-feeding the fire. Hence this pipe is made to form part of the extension C, before described. (See Fig. 1.) At top this feed-pipe H is provided with a lid, having openings controlled by a revolving damper, *h*. (Shown in Figs. 1 and 5.) By means of the damper *h*, the draft from top into stove can be regulated and controlled.

The operation of my improved apparatus is, therefore, as follows: The coal or fuel is fed to the fire until the feed-pipe C H is as full as desired. The lid, with damper *h*, is next placed top of feed-pipe H. As the fire consumes coal, the feed-pipe self-feeds its contained fuel. The draft, as shown by arrows, Fig. 1, is downward. Whatever smoke or gases are top of the fire are passed downward through the burning fuel. In doing so they are, as far as possible, consumed before reaching the flues. The flames, and products of combustion, all pass from between the shell of the stove and the reservoir D, through the flues *e* into the flue-chamber E', from thence up the vertical pipes F into top flue G, finally out of smoke-pipe G'. The passage of the flames, heat, and products of combustion thus described is shown by arrows in Fig. 1, and, as apparent, there is thus offered a very great surface for the radiation of the heat.

Also, it will be noticed, my improved stove is applicable for kitchen and the like purposes. For this modification it is only necessary to remove the pipes F and top flue-chamber G, and provide the flue-chamber E' with a smoke-pipe; the pipe-holes *e* being utilized to receive pots, &c., or can be properly closed. This modification is shown in Fig. 3.

What I claim is—

1. The stove part, consisting of the lower extension part C, water-chamber D, having outward-flaring bottom *d*<sup>3</sup>, its partition *d*, pipes *d*<sup>1</sup> *d*<sup>2</sup>, and top plate E, in combination with the stove-body B, flue-chamber E', and feed-

pipe H, all constructed as herein shown and described, and for the purpose set forth.

2. The stove part consisting of the lower part C, water-chamber D, top plate E, flue-chamber E', pipes F, feed-pipe H, and stove-body B, all combined and constructed to operate substantially as herein shown and set forth.

In testimony of said invention I have hereunto set my hand.

GERHARD H. TIMMERMAN.

Witnesses:

WILLIAM W. HERTHEL,  
CHAS. F. MEISNER.