

G. C. WENZEL.

Apparatus for Variegating Soap.

No. 163,828.

Patented May 25, 1875.

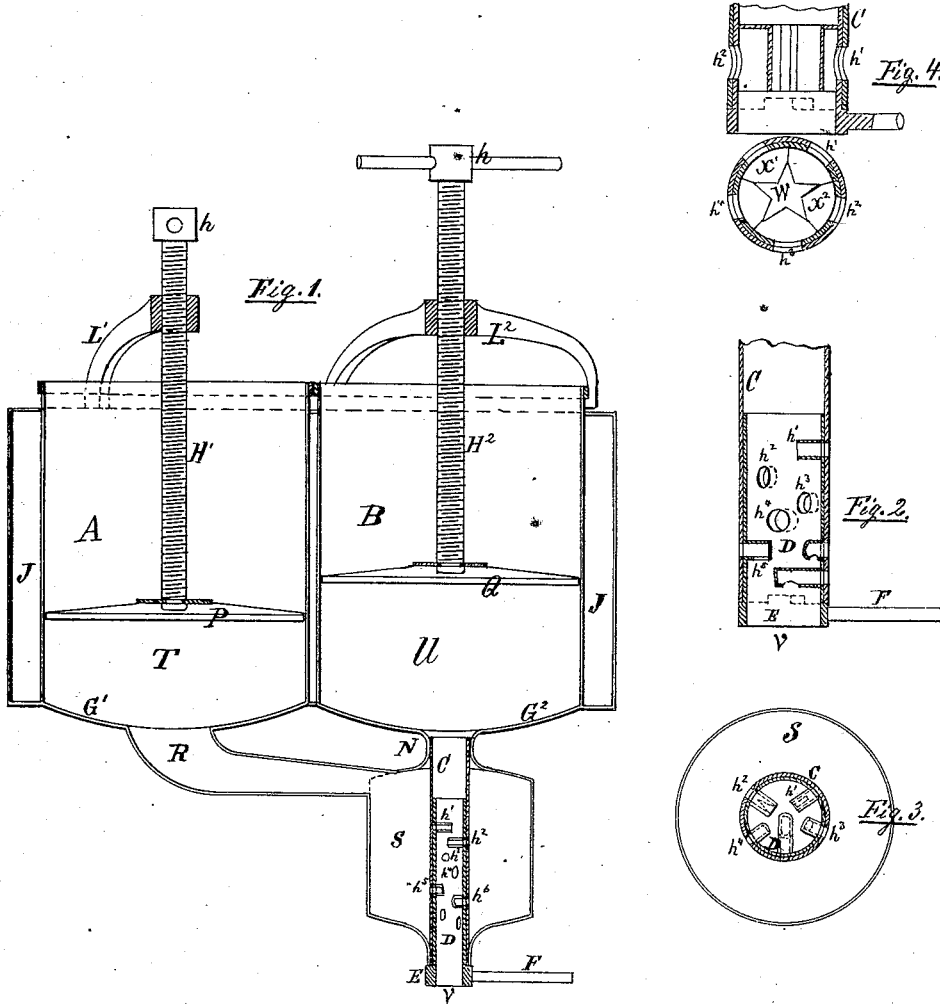

WITNESSES:

*Ed. Gerecke.*  
*Arthur T. Wittie.*

INVENTOR:

*George C. Wenzel*

# UNITED STATES PATENT OFFICE.

GEORGE C. WENZEL, OF NEWBURG, NEW YORK.

## IMPROVEMENT IN APPARATUS FOR VARIEGATING SOAP.

Specification forming part of Letters Patent No. **163,828**, dated May 25, 1875; application filed March 23, 1875.

*To all whom it may concern:*

Be it known that I, GEORGE C. WENZEL, of Newburg, in the county of Orange and State of New York, have invented an apparatus to variegate, in the common way, or with any specific designs, soap, candies, &c., and to mold them, of which the following is a specification:

The object of my invention is to mix soaps of different colors, and at the same time mold the product in suitable forms, so that it has a marbled appearance; or to force the different-colored soap through specially-designed forms, and produce bars which show in their sections the design of the form through which the soap was pressed. This may be done by using soap of two different colors—for instance, red and white or green and white—or of three different colors or more, and the process is as follows; referring to the annexed drawing, in which—

Figure 4 is a vertical section of the apparatus. Figs. 2, 3, and 4, details in larger scale.

A and B are two cylindrical vessels, inclosed by a common steam-jacket, J, by means of which the soaps in the cylinders A and B may be kept up to a suitable degree of heat. In these vessels can be moved close-fitting pistons P and Q by screws H<sup>1</sup> H<sup>2</sup>, which run through straps L<sup>1</sup> L<sup>2</sup>, and which may be turned by hand or any other mechanism. Each of the vessels A and B contains a different-colored soap, which has to pass from the bottom through pipes connected to it. Below the vessel B is another cylindrical vessel, S, connected to the bottom G<sup>2</sup> by the neck N, and through the center of the vessel S passes a pipe or tube, C, which fits well in the neck N, so that the soap from the vessel B has to pass through the tube C and to come out at the lower end V. The tube C is perforated by a number of holes of suitable size, and in its lower end is fitted another tube, D, with corresponding perforations h<sup>1</sup> h<sup>2</sup>. This tube D can be turned around a little, so as to close or open the holes through the sides of the tubes. It has short tubes h<sup>1</sup> h<sup>2</sup> h<sup>3</sup> attached inside, projecting toward the center of the tube D in different lengths, some having the end closed up, some open, some split, and some with holes downward, Figs. 2 and 3. The other large

vessel A is connected to the vessel S by the pipe R, communicating only with the space around the tube C when the inside tube D is turned in such a way that the holes h<sup>1</sup> h<sup>2</sup> are closed; but when, by means of the handle F, the tube D is turned so that the corresponding openings h<sup>1</sup> h<sup>2</sup> are open, the contents of the vessel A will flow through these openings and tubes h<sup>1</sup> h<sup>2</sup> h<sup>3</sup>, and mix with the soap coming from the vessel B through the tube D in such streams as the different openings in the tubes will give them.

The soap in both vessels A and B is in such a state that it has to be pressed out, for which purpose the screws H<sup>1</sup> and H<sup>2</sup> are used. Now, when the soap in this mixed state escapes from the opening V, it is forced in forms and molds, as may be desired, in cakes, balls, or pieces in any shape; and, as the soap is being pressed in the molds and is filling them, the different colors form themselves in the irregular shapes characteristic to marble.

These tubes C and D can be removed, and others inserted in their places, as marked, Fig. 4. The inside tube C contains a design, W, in the shape of a short tube, through which the soap from vessel B is passing, and forming the center of a bar, which on the outside has the soap from vessel A, which forms around the outside of form W in the spaces X<sup>1</sup> X<sup>2</sup> after passing through the openings h<sup>1</sup> h<sup>2</sup> h<sup>3</sup>.

The same arrangement as described before is attached, to close or open the corresponding holes h<sup>1</sup> h<sup>2</sup> in the tubes C and D.

If more than two colors are to be mixed, the vessel S may be divided in two apartments, and the third vessel attached to the other part, and all three colors will come through the opening V in a mixed state.

The jacket J may inclose the whole apparatus, leaving only the opening V free; or the apparatus may be used to boil the soap in at the same time, instead of filling the vessels with the soap after it is ready for molding.

These changes do not affect the process of variegateing the soap or candy, &c., for which purpose this apparatus is intended.

At the end of the tube D may be attached a sliding stop-valve, to prevent the soap from flowing at the time of changing molds.

This mode of pressing the soap into molds

and variegating it at the same time saves an immense amount of waste, which is occasioned by the present method of mixing the soap, cutting and shaping it after it has got cold and hard.

By using this apparatus for molding even plain, single-colored soap, a great deal of labor can be saved. The soap is pressed, by means of the pistons and screws, through the pipe C into the molds, which are held below the lower opening V of the tube C.

What I claim as my invention, and desire to secure by Letters Patent, is—

The adjustable gate, consisting of the annular perforated tubes C and D, with handle F, in combination with the tubes  $h^1$   $h^2$   $h^3$  on the inside of the tube D, for the purpose of mixing colored soaps in different streams, and to regulate the relative quantity of the different kinds of colored soap, substantially as specified.

GEORGE C. WENZEL.

Witnesses:

J. H. GERECKE,  
ARTHUR V. WILTSIE.