

J. R. MITCHELL.

Cutter-Holder for Metal-Lathes.

No. 163,878.

Patented June 1, 1875.

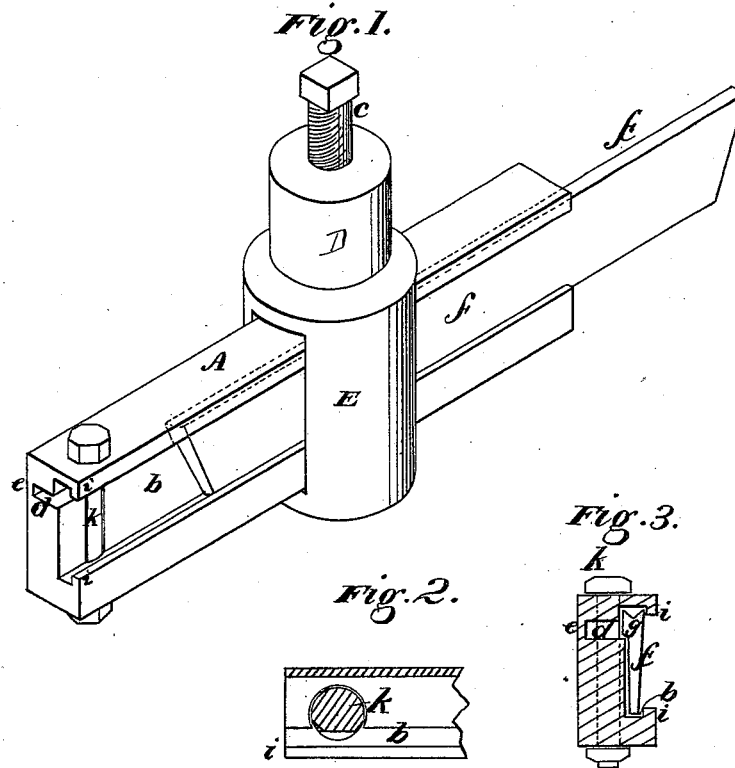

Witnesses
Geo. H. Strong.
Jno. L. Rome

Inventor
Joseph R. Mitchell
by Dewey & Co
his Attys

UNITED STATES PATENT OFFICE.

JOSEPH R. MITCHELL, OF HAYWOOD, CALIFORNIA.

IMPROVEMENT IN CUTTER-HOLDERS FOR METAL-LATHES.

Specification forming part of Letters Patent No. **163,878**, dated June 1, 1875; application filed April 2, 1875.

To all whom it may concern:

Be it known that I, JOSEPH R. MITCHELL, of Haywood, Alameda county, State of California, have invented an Improved Lathe-Tool; and I do hereby declare the following description and accompanying drawings are sufficient to enable any person skilled in the art or science to which it most nearly appertains to make and use my said invention or improvement without further invention or experiment.

My invention relates to an improved tool to be used on lathes, planes, and slotting-machines for cutting off pieces of metal, cutting screw-threads, key-seats, and grooves, and as a turning-tool for ordinary work.

In order to explain my invention so that others will be able to understand its construction and operation, reference is had to the accompanying drawing, forming a part of this specification, in which—

Figure 1 is a perspective view of my holder with the tool being moved into position. Figs. 2 and 3 are sections.

A is the tool-holder, and consists of a bar of metal having a way or recess, *b*, formed longitudinally along one side, in which the tool *f* is held. D is the upper end of the tool-post, in which the tool-holder is secured. Near the top of the recess or way *b* a longitudinal groove, *d*, is made in the tool-holder, which extends horizontally into the metal of the holder, leaving but a thin plate of metal, *e*, connecting the upper part with the lower part, so that a pressure applied upon the upper side of the holder will spring the upper portion downward, as described below.

The tool which I use consists of a thin steel plate, *f*, which fits into the recess or way *b* of the tool-holder, so that it can be moved longitudinally in the recess in either direction. The tool-holder fits in a corresponding hole in the tool-post E, and a set-screw, C, in the tool-post serves to clamp the tool in any desired position (when it is turned down against the upper part of the tool) by springing the upper part downward, and thus pinching the tool between the upper and lower part of the way or recess.

When it is necessary to use a tool in the tool-holder with a wider bit or cutting-edge, I make an offset, *g*, along its upper edge,

which will fit in a recess provided for it in the holder in one side of the way in which the tool slides, thus providing a wide upper or cutting edge, while the lower portion is of the ordinary thickness.

K is a pin or bolt, which passes down through a hole in the end of the tool-holder, so as to pass transversely across the back of the recess in which the bit or tool is held. The hole is so arranged that a portion of the body of the pin or bolt will project into the recess. This pin or bolt has two or more flat faces, either of which can be turned toward the open portion of the recess, and thus provide backings to hold the bits or cutters of different thicknesses rigidly against the lips *i i* of the recess.

The cutter or bit can be provided with a cutting-point at both ends; and, if desired, it can be grooved along its upper edge, as shown, which will be especially useful when cutting screw-threads.

The offset *g* is made along the upper edge of the cutter, and by this means tools of different widths can be used in the holder, while the lower portion of the tool fits in the way or recess.

I thus provide a tool which will be very useful for cutting off pieces of metal, and for doing other work in which it is necessary that the tool should be worked in a deep groove, or where it is desired to work up close to the face of a piece of work.

Having thus described my invention, what I claim, and desire to secure by Letters Patent, is—

1. The tool-holder A, with its way or recess *b* and lips *i i*, in combination with the tool or bit *f* and the clamping or pinching screw *e*, substantially as and for the purpose described.

2. In combination with the tool-holder A, with its recess or way *b*, and bit or cutter, the bolt or pin *k*, with its projecting faces, arranged and operated substantially as and for the purpose described.

In witness whereof I hereunto set my hand and seal.

JOSEPH R. MITCHELL. [L. S.]

Witnesses:

JAMES E. MITCHELL,
JOSEPH GRAHAM.