

O. L. TAYLOR.  
Car-Coupling.

No. 163,897.

Patented June 1, 1875.

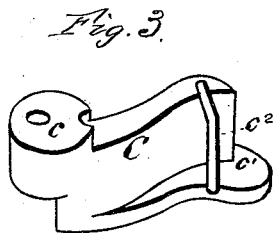
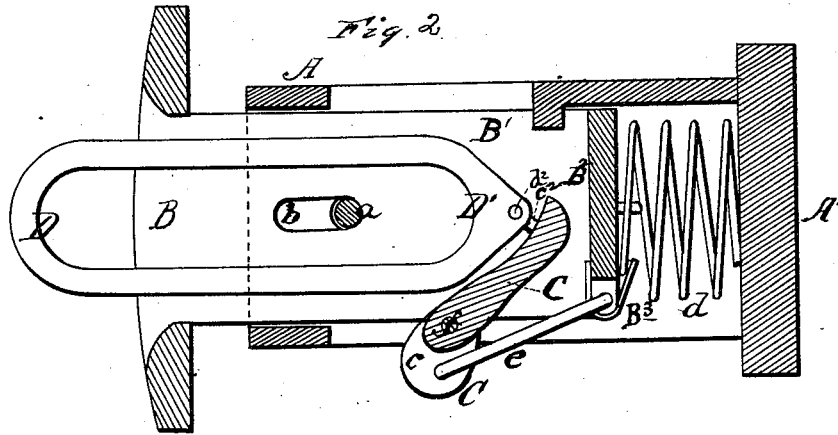
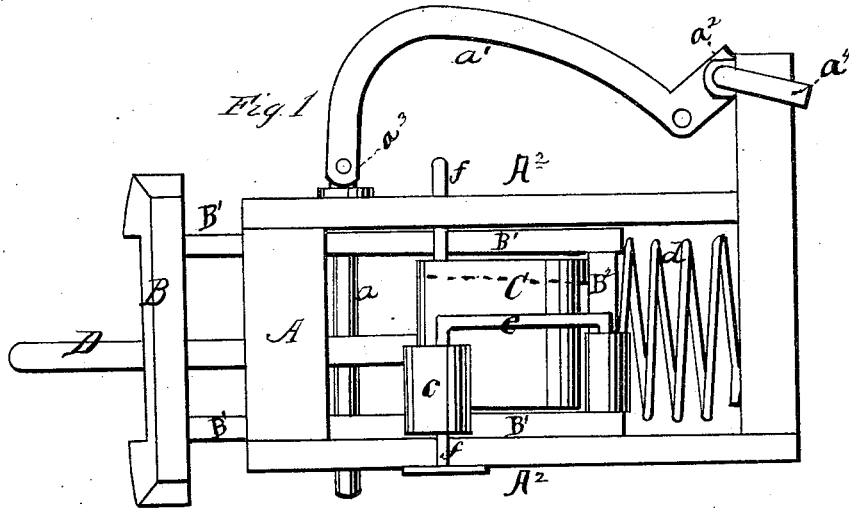

WITNESSES  
*m. E. Chaffee*  
*R. H. Whittlesay*

INVENTOR  
*Oliver L. Taylor*  
*J. S. Lathrop* ATTORNEY

# UNITED STATES PATENT OFFICE.

OLIVER L. TAYLOR, OF MANLIUS, NEW YORK.

## IMPROVEMENT IN CAR-COUPLINGS.

Specification forming part of Letters Patent No. **163,897**, dated June 1, 1875; application filed April 21, 1875.

*To all whom it may concern:*

Be it known that I, OLIVER L. TAYLOR, of the town of Manlius, in the county of Onondaga and State of New York, have invented certain new and useful Improvements in Car-Couplers; and I do hereby declare that the following is a full, clear, and exact description thereof, which will enable others skilled in the art to which it pertains to make and use the same, reference being had to the accompanying drawing, and to the letters of reference marked thereon, which form a part of this specification.

My invention relates to improvements in car-couplings, whereby the same may be automatically coupled together without necessitating an attendant passing between or beneath the cars for the purpose of operating or guiding any of the parts of the device, the nature of which will be hereinafter more fully explained by reference to the drawings.

Figure 1 represents a plan, and Fig. 2 a horizontal section, of a car-coupler constructed according to my invention. Fig. 3 shows a detached perspective view of the lever C.

In each of the views similar letters of reference are employed wherever they occur.

A represents the draw-head, which is formed hollow and with parallel sides. B is the buffer-head, provided with parallel extensions or bearing-surfaces B<sup>1</sup>, connected together at their rear ends by an upright piece, B<sup>2</sup>. *d* is a spiral spring placed between the rear end A<sup>1</sup> of the draw-head and the upright piece B<sup>2</sup>, for the purpose of keeping the buffer B forward and yielding, when necessary, to break the force of concussion when two buffer-heads come together. B<sup>3</sup> is a loop or projection formed on or affixed to the upright piece B<sup>2</sup>. To this loop B<sup>3</sup> one end of a connecting-link, *e*, is pivoted, the opposite end of which is connected to a projection, *c*, on the rear end of a bent lever, C. The bent lever C is pivoted at one end to the upper and lower plates A<sup>2</sup> A<sup>2</sup> of the draw-head A by means of a pin, *f*, while at the opposite end it is provided with a projecting pin or hook, *e*<sup>2</sup>, adapted to be received into a loop or hole, *d*<sup>2</sup>, formed in the rear end D<sup>1</sup> of the coupling-link D. *a*<sup>1</sup> is a bent lever pivoted to a shaft or axle, *a*<sup>2</sup>, carried by brackets or projections from the draw-

head A, or rear end of the car to which said draw-head is attached. The lever *a*<sup>1</sup>, at its front end, is, by pin-joint *a*<sup>3</sup>, connected to the coupling-pin *a*, which is adapted to pass freely through slots or openings in the plates A<sup>2</sup> A<sup>2</sup>, and also through an elongated slot, *b*, in the plates B<sup>1</sup> B<sup>1</sup> of the buffer B. *a*<sup>4</sup> is a lever-handle (of which there may be one on each side of the car) affixed to the end of the axle *a*<sup>2</sup>, for the purpose of operating the lever *a*<sup>1</sup> from the side of the car, to lift the coupling-pin *a* from the side of the car without necessitating the attendant going between or under, or placing the hand between, the cars. The upper surface of the bent lever C is provided with a plate or projection, *c*<sup>1</sup>, adapted, when required, to come beneath the lower end of the coupling-pin *a*, and hold the said coupling-pin up and clear of a link, D, of an adjoining car required to be coupled.

In order that my invention may be fully understood, I will now describe the operation of the same.

A car-coupling affixed to a given car being arranged as shown in Figs. 1 and 2, with the coupling-link D in position, when it is required to couple the said link D with another coupler, it is only necessary to raise the pin *a* by means of the lever *a*<sup>1</sup> and handle *a*<sup>4</sup>, until the buffer-heads B of the adjoining couplers come together, when the link D, by means of the backward movement of the bumper B B<sup>1</sup>, and consequent movement of the lever C, will be caused to move forward, so that the pin *a* may drop into the loop thereof and couple the cars together. When it is necessary to uncouple a pair of cars, it is simply necessary to back the cars slightly, to relieve the links D of the strain of the draft of the train. The pin *a* must then be raised by means of the lever *a*<sup>1</sup> and handle *a*<sup>4</sup>. The backward movement of one car against the other will cause the plate *c*<sup>1</sup> of the bent lever C to come under the hole through which the coupling-pin *a* passes, and thus insure the same against accidentally falling into the loop of the coupling-pin D, and thus again coupling the cars together.

Having thus described my invention, what I claim as new, and desire to secure by Letters Patent, is—

1. The combination, with a hollow draw-head, A, provided with parallel sides, and a buffer-head, B, having parallel bearing-plates B<sup>1</sup>, of the connecting-link *e*, bent lever C, plate *c*<sup>1</sup>, pin *c*<sup>2</sup>, and link D, substantially as shown and described.

2. The combination, with a draw-head, A, buffer B B<sup>2</sup> B<sup>3</sup>, connecting-link *e*, lever C, plate *c*<sup>1</sup>, pin *c*<sup>2</sup>, and coupling-link D, of the coupling-pin *a*, lever *a*<sup>1</sup>, axle *a*<sup>2</sup>, and handle *a*<sup>4</sup>,

all constructed to operate substantially as set forth.

In testimony that I claim the foregoing as my own I affix my signature in presence of two witnesses.

OLIVER L. TAYLOR.

Witnesses:

JASPER L. JEWELL,  
JNO. D. PATTEN.