

J. D. WESTGATE.
Machine for Cutting Button-Holes in Cloth,
Leather, &c.

No. 163,904.

Patented June 1, 1875.

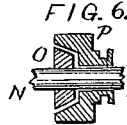
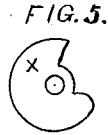
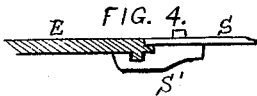
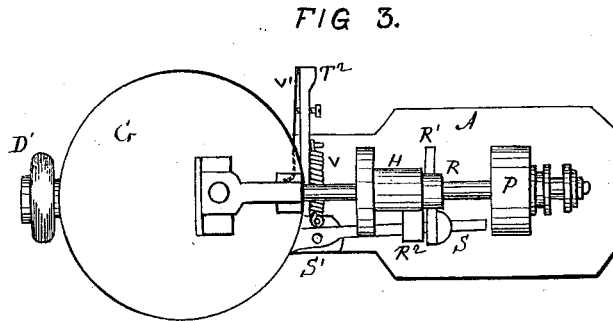
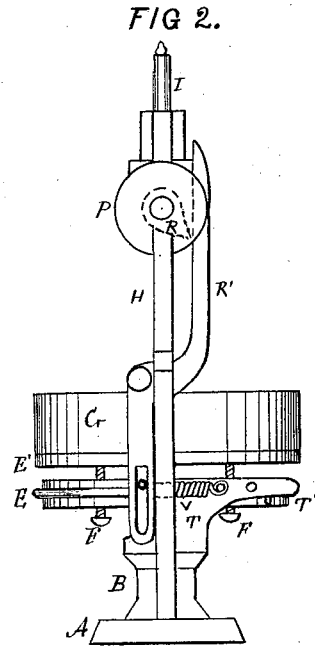
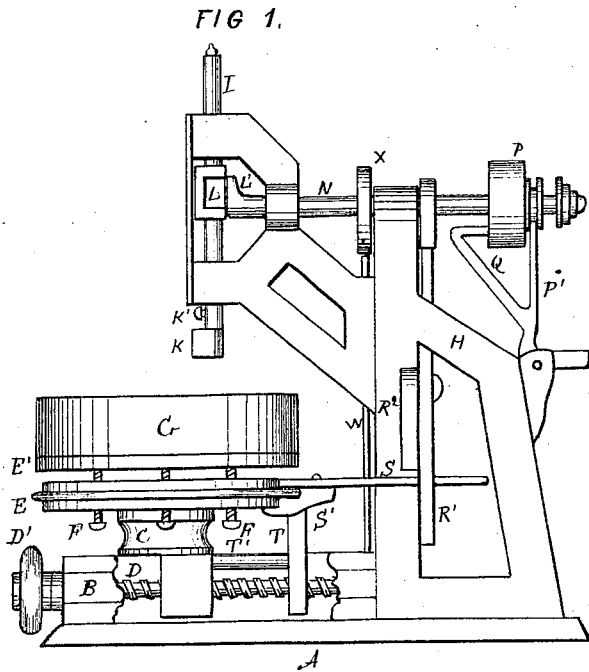

WITNESSES.

W. E. Chaffee.
Harry Coleman.

Joseph D. Westgate
By his Atty. J. Dennis

UNITED STATES PATENT OFFICE.

JOSEPH D. WESTGATE, OF LYNN, MASSACHUSETTS, ASSIGNOR TO HIMSELF
AND ANN E. BODWELL, OF SAME PLACE.

IMPROVEMENT IN MACHINES FOR CUTTING BUTTON-HOLES IN CLOTH, LEATHER, &c.

Specification forming part of Letters Patent No. **163,904**, dated June 1, 1875; application filed
May 3, 1875.

To all whom it may concern:

Be it known that I, JOSEPH D. WESTGATE, of Lynn, Essex county, in the State of Massachusetts, have invented certain new and useful Improvements in Machines for Cutting Button-Holes in Cloth, Leather, &c.; and I hereby declare the following to be a full and exact description thereof, reference being had to the accompanying drawings forming part of this specification.

The nature or essence of my invention consists in the particular construction, combination, and arrangement of devices forming the improvements described and claimed in the following specification:

In the accompanying drawings, Figure 1 is a side elevation of a machine with my improvements, and Fig. 2 an elevation of the front end; and Fig. 3, a plan of the same machine; Fig. 5, one of the cams.

In the above-mentioned drawings, A is the base, to which the ways B are fastened, on which ways the transverse block C travels, being moved by the screw D and hand-wheel D'. The disk E is made in the form shown, and arranged to turn on the block O and carry the adjusting-disk E', which is connected to the disk E by the adjusting-screws F F, and on the top of the disk E' the table-block G is fastened in some convenient manner.

The stand or frame H may be made in the form shown, or in such other form as will answer the purpose, and is fastened to the base A, to support the cutter-stock I and crank-shaft N, which are arranged to operate in it. The cutter-stock I is fitted to traverse vertically in the arms of the stand H, and is provided with a socket for the button-hole cutter K, which is fastened in it by the screw K'. The stock I is enlarged in the middle, and has a groove across it horizontally for the block L to traverse in, which block is on the crank L' of the shaft N, which shaft is fitted to turn in the frame H and receive the power that is to operate the machine.

There is a conical disk, O, (shown in section, Fig. 6,) fastened to the shaft N, upon which disk the loose pulley P is traversed by the shipper P', to lock it to the shaft and turn it to operate the machine, a belt from some moving power being applied to the pulley P. The shipper P' carries an arm, Q, which is carried against the disk O, to stop the shaft when the pulley is moved from the disk.

To turn the disks E and E' and block G the cam R is fastened to the shaft N to operate the lever R', which works on a pin in the stand R², fastened to the frame H. The lower end of the lever R' is slotted for the end of the lever S, which works on a pin in the clutch-block S', which is fitted to the horizontal and vertical flanges of the disk E. (Shown in section in Fig. 4.) To pull the clutch-block S' back after it has moved the disk, I make a stand, T, to traverse on the ways B, and connected to the block C by the rod T¹, so that it will traverse with the block and disk. This stand T is provided with an arm, T², to which one end of the spiral spring V is hitched, and the other end to the block S'. The flat spring V' is also fastened to the arm T², and acts against the disk E, to prevent it from being turned back by the block S'. When the end of the lever S is moved out from the frame the short end gripes the disk E and turns it, and when the lever is released the spiral spring V pulls the lever back, the block S' slipping on the disk. The rod W is fitted to traverse vertically in the frame H, and there is a spiral spring under it at the base. This rod W is to be connected with a treadle when the machine is run with a treadle, and is intended to act on the cam X on the shaft N to stop the machine.

The table-block G may be made of wood, metal, or other material, and the cloth, leather, or other materials in which the button-holes are to be cut or punched may be moved under the punch or cutter, as desired.

I claim as my invention—

1. In a machine for cutting button-holes,

the combination of the ways B and screw D with rotating disk E and table-block G, all substantially as and for the purpose described.

2. In combination, the rotating cam R, lever R¹, clutch-lever S, and flanged disk E, for turning the table block G, as shown and described.

3. In combination with the loose pulley P,

the shipper P', provided with an arm, Q, adapted to apply friction to the disk and stop further motion when the pulley is moved back.

JOSEPH D. WESTGATE.

Witnesses:

CHARLES F. GREEN,
FRANCIS BREED.