

D. P. MAYHEW.  
Gas-Regulator.

No. 163,937.

Patented June 1, 1875.

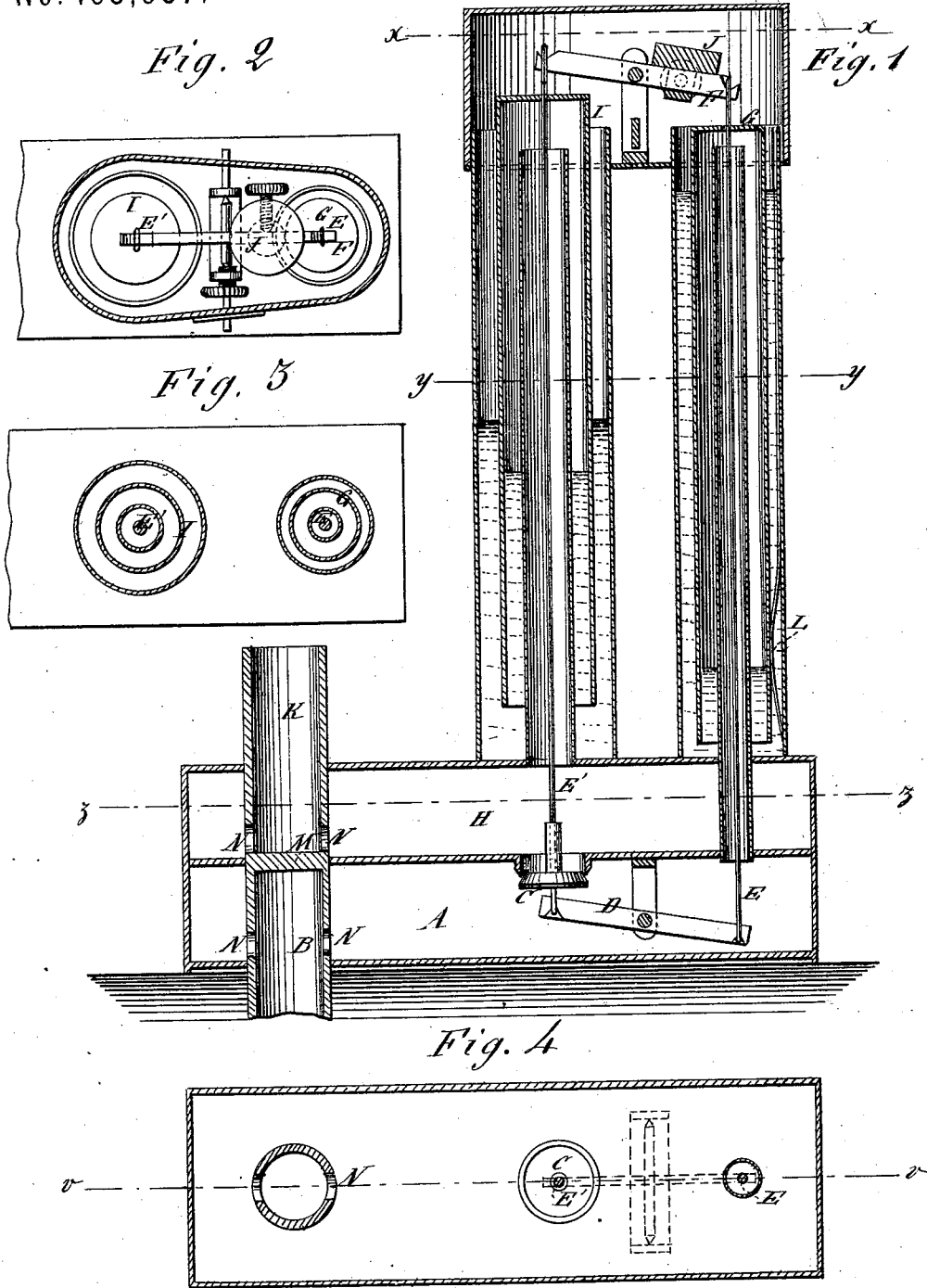

WITNESSES:

*C. A. Newell*  
*A. J. Terry*

INVENTOR:

*D. P. Mayhew*  
BY *Wm. L. ...*  
ATTORNEYS.

# UNITED STATES PATENT OFFICE.

DAVID P. MAYHEW, OF DETROIT, MICHIGAN.

## IMPROVEMENT IN GAS-REGULATORS.

Specification forming part of Letters Patent No. **163,937**, dated June 1, 1875; application filed March 20, 1875.

*To all whom it may concern:*

Be it known that I, DAVID P. MAYHEW, of Detroit, in the county of Wayne and State of Michigan, have invented a new and Improved Gas-Regulator, of which the following is a specification:

My invention comprises a chamber receiving gas from the main, in which is an exit-valve, which is balanced by a water-valve, and is also connected by a lever and a couple of rods with another lever, having a counterpoise to be set according to the pressure wanted, and arranged in relation to another water-valve receiving the gas from the exit-chamber, and acting upon the lever to close the exit-valve whenever there is an excess of pressure in the exit-chamber.

Figure 1 is a sectional elevation of my improved gas-regulator, taken on the line *v v* of Fig. 4. Fig. 2 is a horizontal section taken on the line *x x*. Fig. 3 is a horizontal section taken on the line *y y*, and Fig. 4 is a horizontal section taken on the line *z z*.

Similar letters of reference indicate corresponding parts.

A is the chamber receiving the gas from the main by the pipe B, and containing the exit-valve C, which is connected, by lever D and rods E E', with the counterpoise-lever F. G is the movable cap of a water-valve, through which rod E passes for a guide to said cap, the valve being open to the chamber A, to balance the pressure of the main on valve C. I is the cap of another water-valve, through which rod E' passes for a guide, and which is open to the exit-chamber, to be subject to the pressure therein. J is an adjustable weight on the lever F, to be set according to the pressure wanted in the exit-pipe K. It will be seen

by examination of the drawings that whatever the pressure may be in the main the exit-valve will be so balanced that it will open by the excess of weight of cap I over that of cap G and counterpoise J acting through lever F and rod E', and that as soon as the pressure rises in the exit-chamber above the point for which the weight J is set the cap I will rise against lever F and close the valve until the pressure falls in the exit-chamber, so that said excess of weight of cap I over that of cap G and counterpoise J can move lever F and open the valve C again. The caps G and I are controlled by the rods securely fixed to them, and working in the notches of levers D and F. A spring, L, is used when needed to check any tendency to longitudinal vibration.

The inlet and outlet pipes have a common diaphragm, to which they are joined, and openings N on all sides of the pipes, and on either side of the diaphragm M, into the chambers.

Having thus described my invention, I claim as new and desire to secure by Letters Patent—

1. In a gas-regulator, the combination of the water-valves G I, communicating, respectively, with the receiving and exit chambers A H, and connected with the exit-valve C, substantially as herein described, for the purpose set forth.

2. The combination of the receiving-chamber A, exit-chamber H, exit-valve C, levers F D, rod E E', and water-valves G I, substantially as specified.

DAVID P. MAYHEW.

Witnesses:

G. W. MOORE,  
T. C. OWEN.