

J. McCORMICK.
Corn-Harrow.

Patented June 1, 1875.

No. 164,013.

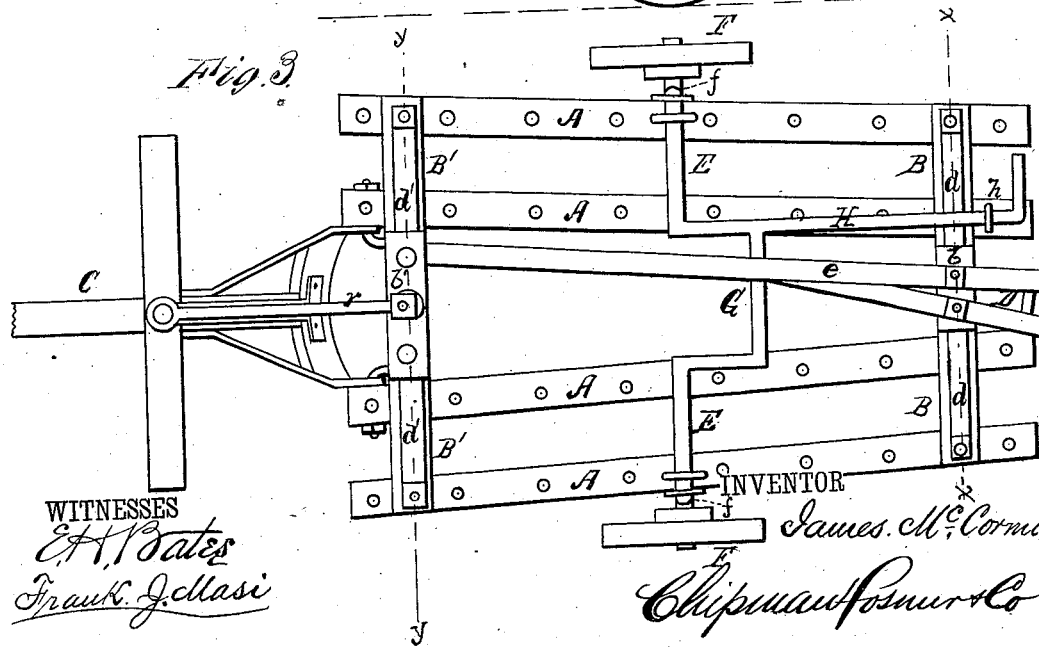
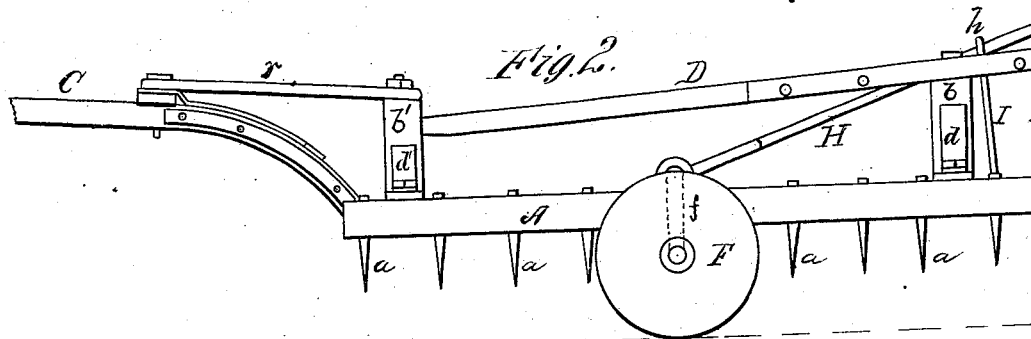
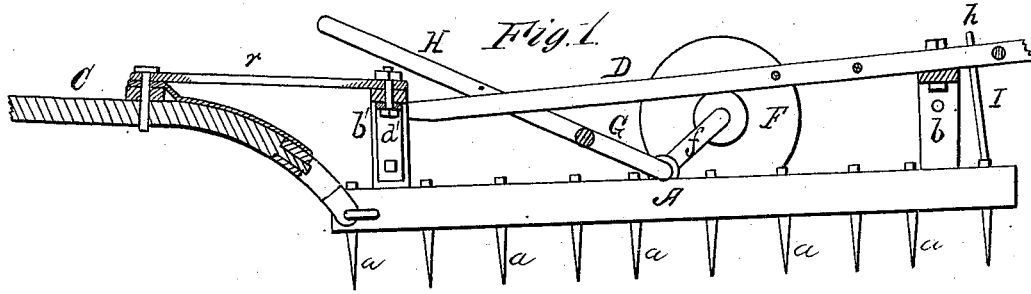

WITNESSES
E. H. Bates
Frank J. Chasi

INVENTOR
James M. McCormick
Chipman & Osner & Co

Attorneys

J. McCORMICK.
Corn-Harrow.

Patented June 1, 1875.

No. 164,013.

Fig. 4.

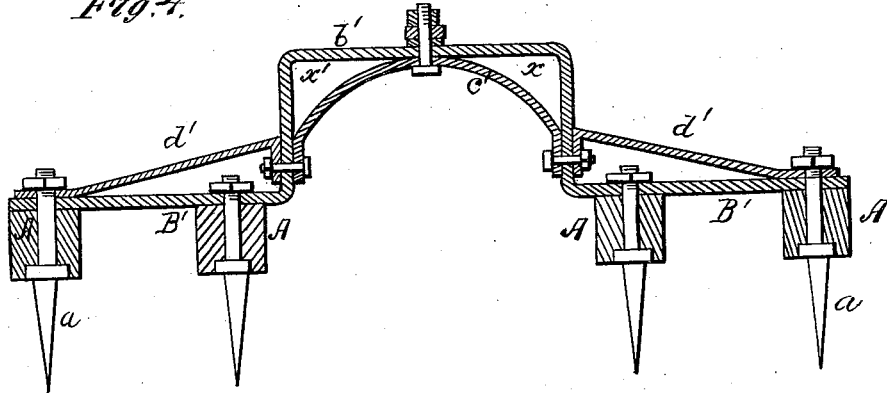
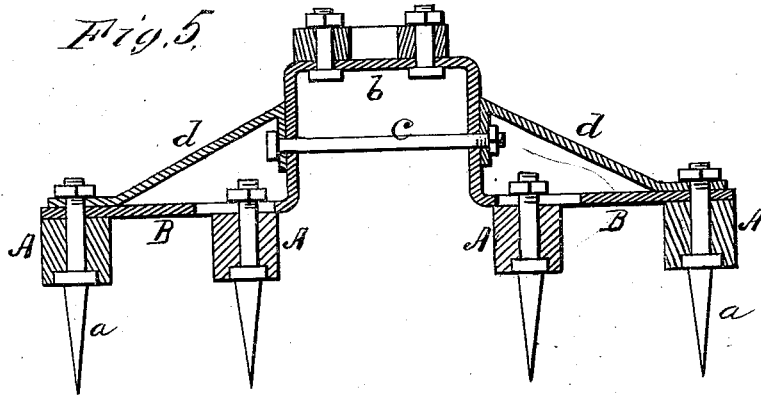

Fig. 5.



WITNESSES
E. H. Bates
Frank J. Massi

INVENTOR
James M. McCormick
Chipman Fossum & Co

Attorneys

UNITED STATES PATENT OFFICE.

JAMES McCORMICK, OF PEORIA, ILLINOIS.

IMPROVEMENT IN CORN-HARROWS.

Specification forming part of Letters Patent No. **164,013**, dated June 1, 1875; application filed August 29, 1874.

To all whom it may concern:

Be it known that I, JAMES McCORMICK, of Peoria, in the county of Peoria and State of Illinois, have invented a new and valuable Improvement in Corn-Harrow; and I do hereby declare that the following is a full, clear, and exact description of the construction and operation of the same, reference being had to the annexed drawings making a part of this specification, and to the letters and figures of reference marked thereon.

Figure 1 of the drawing is a representation of a section view of my corn-harrow. Fig. 2 is a side view. Fig. 3 is a plan view, and Figs. 4 and 5 are transverse sectional views on lines *x x* and *y y* of Fig. 3.

This invention has relation to implements for harrowing corn; and the novelty consists in the employment of certain devices for the improvement of the construction of a harrow, as will be hereinafter more fully set forth.

In the annexed drawing, A designates the longitudinal tooth-bearing bars of my improved harrow, each having a suitable number of teeth and converging toward a common center in the rear, as shown in Fig. 3. The space between the said harrows is, in general terms, about equal to the distance between the rows in a field of corn, and it is intended that the growing corn shall pass between the harrow-bars A, and thus escape the action of the teeth *a*. In this manner the said teeth will thoroughly eradicate and tear up any weeds growing between the corn-hills, and yet in no way endanger the young corn.

The bars A are rigidly secured together by means of metal braces B B', whose central portions situated between the inner bars is provided with bridged portions *b b'* raised above the horizontal part of the said braces, as indicated in Figs. 4 and 5. The rear brace B is provided with a rectilinear brace-rod, *c*, which passes from side to side through the bridge *b*, and is then secured to the exterior braces *d* by means of a suitable bolt and nut, the free ends of the said braces being firmly attached to a tooth, *a*, upon the rear ends of

the outer bars of the harrow-frame. The bridge *b'* is similarly braced to the bridge *b*, with this difference: that the interior brace *c'* of the former is curvilinear, thus providing angular spaces *x x'* between the bridge and its brace, for a purpose hereinafter to be explained.

Upon the front end of the harrow-frame a draft-pole, C, is applied in the usual well-known manner, and it is braced by a rod, *r*, rigidly but removably applied to the said pole, and to the front bridge, as shown in Figs. 1 and 2.

D indicates the plow-handle, the main part *e* of which is straight, and is removably but rigidly secured to the rear bridge *b*, its front end being stepped in the space *x*, between the brace *c'* and the bridge *b'*. When thus stepped the handles will have an inclination to the left, as shown in Fig. 3, and will be in position to be conveniently held by a right-handed man walking in a furrow upon the left of the implement. When the front end of the said handle is stepped in the space *x'* the rear ends will incline to the right, when they will be in an equally convenient position, to be held by a left-handed operator. These handles are also nearly parallel to the main frame of the harrow, and hence the downward pressure of the driver being but slight the teeth will not be unnecessarily driven into the soil.

Upon the upper surface of the harrow-frame is secured, in suitable bearings, the axle E of two transporting-wheels, F, the spindles of which are upon a downwardly-bent portion, *f*, as shown in dotted lines, Fig. 2. The central portion of this axle is provided with a crank-arm, G, shown in Fig. 3, to which is rigidly secured one end of a lever, H.

When this lever is thrust downward and rearward in the position shown in Fig. 2 the body of the harrow will be raised from the ground, disengaging the teeth *a* therefrom, and permitting the implement to be driven to any desired point.

What I claim as new, and desire to secure by Letters Patent, is—

1. The arch B' , having the brace c' and openings x and x' , in combination with the removable and adjustable plow-handle D , substantially as and for the purpose set forth.

2. In combination with the draft-pole c , the removable rod r , attached in the manner as described, and for the purpose set forth.

In testimony that I claim the above I have hereunto subscribed my name in the presence of two witnesses.

JAMES McCORMICK.

Witnesses:

I. P. McDOWELL,
W. G. McDOWELL.