

G. M. PRATT.  
Chucks for Metal Drills.

No. 164,032.

Patented June 1, 1875.

Fig. 1.

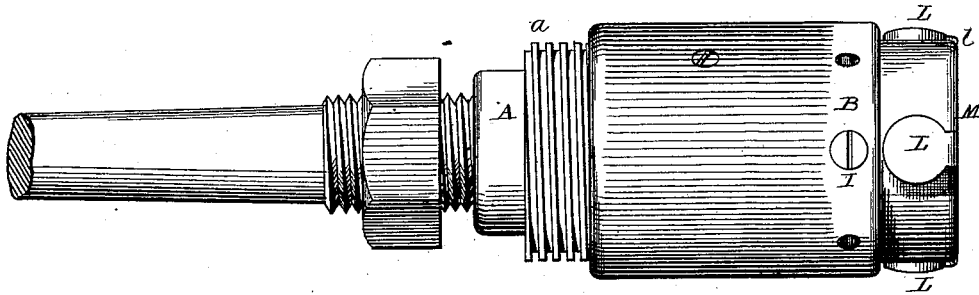

Fig. 2.

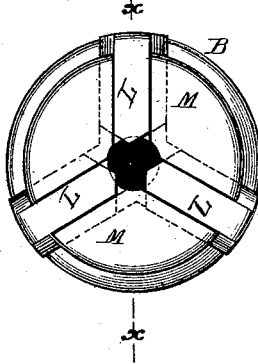

Fig. 3.

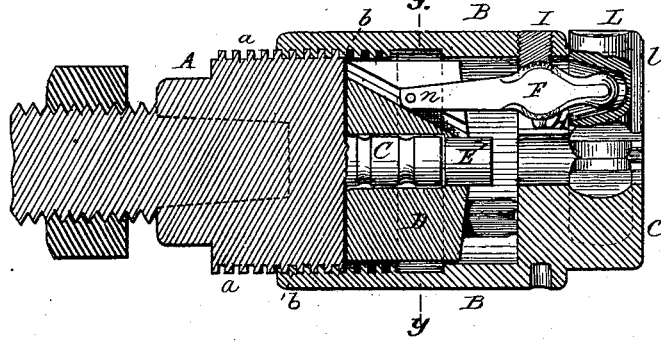

Fig. 4.

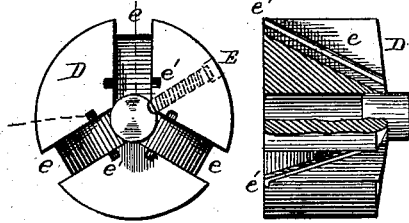

Fig. 5.

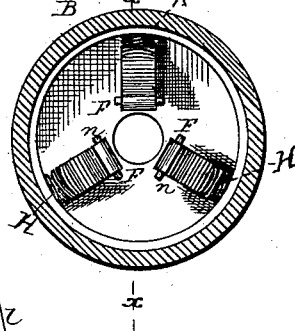

Fig. 6.



Attest:  
J. S. Brown  
A. H. Norris.

Inventor.

George M. Pratt  
By James L. Norris.

# UNITED STATES PATENT OFFICE

GEORGE M. PRATT, OF MIDDLETOWN, CONNECTICUT.

## IMPROVEMENT IN CHUCKS FOR METAL DRILLS.

Specification forming part of Letters Patent No. 164,032, dated June 1, 1875; application filed March 29, 1875.

*To all whom it may concern:*

Be it known that I, GEORGE M. PRATT, of Middletown, in the county of Middlesex and State of Connecticut, have invented certain new and useful Improvements in Drill-Chucks, of which the following is a specification:

This invention relates to certain improvements in that class of self-centering drill-chucks, in which the drill or tool is grasped and held by means of sliding jaws adapted to move to and from a common center in a suitable carrier, being actuated by means of a series of levers operated by means of the chuck-head.

In drill-chucks of this class as hitherto constructed the clutches have been confined in radial grooves cut in the face of the carrier, by means of an annular cap fitting over the same. As thus constructed the clutches are prevented from remaining flush with the surface of the chuck, thereby rendering them liable to injury by breaking or twisting. Besides, the cover or cap interferes with a straight shank-drill, preventing the insertion of the same when of large size, and causing the clutches to wear to such an extent as to be better adapted after a little use to hold a taper shank-drill than a straight shank.

My invention consists in a new device for operating the levers by means of which the clutches are actuated, consisting of a cylindrical follower, swiveled to the clutch-head, and working in the hollow part of the chuck-holder behind the levers, said follower being provided with three longitudinal recesses with inclined bottoms, in which the ends of the levers fit, and by which they are actuated, as will be fully hereinafter described and set forth.

In the drawings, Figure 1 represents a side view of my improved chuck. Fig. 2 is a front view of the same. Fig. 3 is a sectional view. Fig. 4 is detached views of the follower attached to the chuck-head. Fig. 5 is a rear view of the chuck-holder, and Fig. 6 is detached views of one of the levers and sliding clutches.

The letter A represents the chuck-head provided with a shank or spindle, by which it may be secured to the mandrel of the lathe, and having a male screw, *a*, formed upon its

periphery, which gears into a female screw, *b*, formed in the interior of the chuck-holder B, as shown in Figs. 1 and 3. To the front of the head B is attached a spindle, C, carrying a cylindrical follower, D, which is held thereon by means of a screw, E, setting behind the head B' on said spindle. This follower is provided with three longitudinal slots, *eee*, the bottoms of which are inclined from the periphery of said follower at the rear to the center in front of the same, for the purpose to be hereinafter described. F F F represent the levers which actuate the clutches L L L. Said levers pass through slots H H H in the forward end of the holder B. Said levers are enlarged and rounded at their fulcrums, forming spherical bearings for the same, which rest against adjustable set-screws I I I passing through the walls of the holder B. L L L represent the sliding clutches, each consisting of a short cylinder of metal, provided with a broad longitudinal feather, *l*, and properly beveled on its lower edge, as shown in Fig. 6. These clutches are adapted to fit in a series of radial cylindrical chambers, M M M, near the front or face of the holder B, said holder being slotted in front of the cylinders to receive the feathers on the clutches, which come flush with the face or front of the chuck. The front ends of the levers fit into recesses *m* of the clutches, the rear ends being provided with pivots *n*, to return the clutches or throw them out when the rear ends of the levers are released by the follower. To effect this the recesses in the follower are grooved on the sides on a line parallel with the inclined bottom, as shown at *e'*, Fig. 4. The pivots on the ends of the levers being set into these grooves will throw the levers back upon the return motion of the follower. The follower may, if desired, be provided with a longitudinal groove upon its periphery, into which the end of a set-screw, passing through the wall of the holder, may project, to prevent the follower from turning with the chuck-head, and prevent the holder B from being screwed off from the chuck-head when opened full size.

The operation of my improved chuck is as follows: The parts being in position as shown in Fig. 1, a drill of any convenient size is inserted between the clutches. The chuck-head

is then turned so as to advance the follower, when the inclined bottoms of the recesses will force the rear ends of the levers apart, pressing the clutches together in the radial chambers toward their common center, causing the same to grasp and hold the tool. When the tool is to be released the operation is reversed, when the pivots and the grooves in the follower will act upon the levers, bringing them back to their original positions and throwing the clutches away from the tool.

Having thus described my invention, what I claim as new, and desire to secure by Letters Patent, is—

1. In combination with the chuck-head and levers, the cylindrical follower, with longitud-

inal recesses, having inclined bottoms, for the purpose of operating said levers without straining the same, substantially as set forth.

2. In combination with the cylindrical follower, having longitudinal recesses, and the levers for actuating the clutches, the inclined grooves in the side walls of said recesses for returning the levers and clutches, as and for the purposes set forth.

In testimony that I claim the foregoing I have hereunto set my hand.

GEO. M. PRATT.

Witnesses:

A. PUTNAM,  
J. W. MACKY.