

P. COOK.

Machine for Cutting Hoops.

No. 164,077.

Patented June 8, 1875.

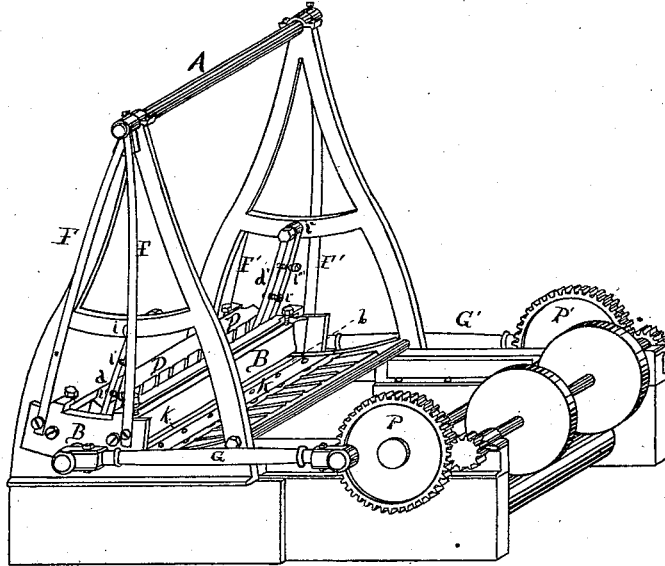

Fig. 1.

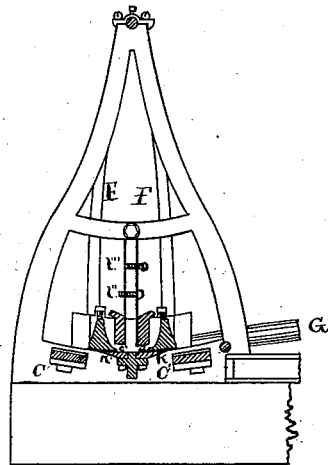

Fig. 2.

Witnesses

Charles A. Reuwick
John D. Day

Inventor

Peter Cook
By Taggart Simonds & Fletcher
Attys

UNITED STATES PATENT OFFICE.

PETER COOK, OF DETROIT, MICHIGAN.

IMPROVEMENT IN MACHINES FOR CUTTING HOOPS.

Specification forming part of Letters Patent No. **164,077**, dated June 8, 1875; application filed September 5, 1874.

To all whom it may concern:

Be it known that I, PETER COOK, of the city of Detroit, in the county of Wayne and State of Michigan, have invented a new and Improved Machine for Cutting Hoops. The following is a full, clear, and sufficient description thereof, reference being had to the accompanying plate of drawings and to the letters of reference marked thereon, and the same are made a part of this specification.

The nature of my invention relates to a new and improved machine for cutting beveled hoops for barrels by causing a steamed bolt of the requisite thickness to be fed backward and forward over a double knife or set of knives having the edges in opposite directions, so as to have a hoop cut from the bolt at each vibration of the bolt, the thickness of the hoop being regulated by guiding concave beds upon which the bolt falls by its own gravity, and the form of the hoop cut off being controlled by a feeding-guide. This feeding-guide is hung upon a frame above the set of knives, and swings back and forth upon a pivot or bearing attached to the frame placed at such height that the bolt held by the feed-guide will be fed against the knives at such an angle as to make a hoop of the desired form and bevel.

In the drawings, Figure 1 represents my invention in perspective, with its various attachments and the means of propulsion. Fig. 2 represents a cross-section of my invention taken through its center.

In Fig. 1, the swinging hopper B is swung toward the front part of the machine, and exposes to view the concave and one knife, K, a small portion of the bed-piece to which the knives are attached, marked *b*, and also a small portion of the knife K'. The swinging hopper B is hung and kept in place by the supporters F F', which depend from the upper shaft A, which shaft also connects the two upright parts of the frame together. The sides of the hopper B are of such form as to protrude under the feed-guide D far enough to touch and operate upon the bolt while being cut into hoops. G G' are cranks, communicating motion from the spur-wheels P P' to the swinging hopper B. The knives K K' are fastened to the bed-piece on which they rest by set-screws or bolts, as shown in Fig. 1. Hanging,

by means of the suspenders *d d*, on pivots *i i* is the feed-guide D, which consists of two parts or jaws provided with ribs on the inner side. The suspenders which sustain this inner feed-box are made from a single piece of metal bent double to hang over the pivots *i i*, and its two parts are adjustable to and from each other by means of the set-screws *l l' l'' l'''*, so that the inner faces of the two parts that form the feed-guide D may be separated from and brought toward each other at pleasure. The feed-guide D is hung so as to oscillate within the hopper B, and should be so adjusted as to nearly rest upon the protruding lips *e e'*, the office of the guide being simply to feed the bolt to the knives at the angle desired, and the office of the lips *e e''* being to vibrate the bolt against the knives. These lips should be so adjusted as to pass in close proximity to the upper surface of the knives, and thus prevent any part of the bolt from being split or broken away instead of being cut. The height at which the pivots *i i* shall be placed will be determined by the bevel that is needed. The higher the pivots are the less the bevel of the hoop will be. The feed-guide D being within the sides of the outer feed-box B, motion is communicated to it simply by contact when the hopper is in motion. The concave beds are shown in Fig. 1 and in Fig. 2 by C C', and are so constructed as to fall below the upper surface of the knives if produced over them, and are made adjustable by means of set-screws underneath, (not shown,) so that the space between the edge of the knives and the upper surface of the concaves will be the gage by means of which the thickness of the hoops to be cut can be regulated. The sides of the jaws of the feed-guide D should be oscillated to such an extent as to carry the bolt, which passes between its two sides, beyond the edge of the knives on both sides. This will permit the bolt to fall by its own gravity upon the concave beds C C', and be in position to receive the knife at the proper place as the hopper B and feed-guide are swung back.

In using my improved machine the power is communicated by means of the cranks G G' to the hopper B, to which is given a vibrating or oscillating motion, the bottom of the feed-box following the arc of a circle having its center

at the upper shaft A. The bolt to be operated upon should be produced of such thickness as will be equal to the width of the hoop desired, and placed edgewise between the two parts of the feed-guide D, which should be so adjusted as to permit the bolt to slide down easily by its own gravity. When the machine is put in motion the bolt will be carried backward and forward by the projecting lips of the hopper far enough so that it will fall by its own gravity upon the concave bed C or C', and, inasmuch as the pivot on which hangs the feed-guide D is so much lower than the pivot which supports the swinging hopper B, the bolt will fall upon the concave bed at an angle, so that as it is forced against the knife by the return motion of the hopper the strip or hoop cut off will be thicker on the edge first cut by the knife than on the other, and the portion of the bolt uncut will be correspondingly thinner at that point. On the return motion, after being forced past the other knife so that the bolt will fall upon the concave, the thicker part will first touch the knife, and the bevel will then be

made the reverse of the former bevel, and thus the entire bolt will be evenly cut away, each hoop cut away having precisely the same bevel.

I do not claim, broadly, the hopper B swinging over the knives K K' and concave beds C C', as that is now old, and covered by a former patent granted to me; but

What I claim to have invented, and to be new, is—

1. The feed-guide D, made in two parts, hung upon the adjustable suspenders *d d'*, and oscillating over the knives K K' and concave beds C C', substantially as and for the purpose described.

2. The feed-guide D, hung upon a short arm, in combination with the swinging hopper B, hung upon a longer arm, and both oscillating over the knives K K' and concave beds C C', as and for the purpose described.

PETER COOK.

In presence of—
O. H. SIMONDS,
JOHN D. BOYD.