

J. T. JONES.

Sewing-Machine Take-Up.

No. 164,179.

Patented June 8, 1875.

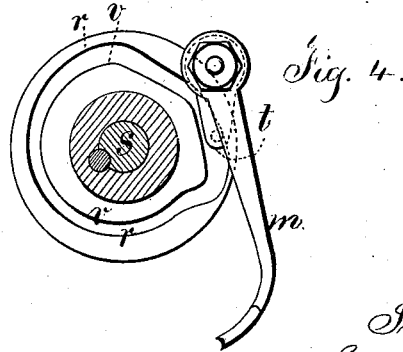
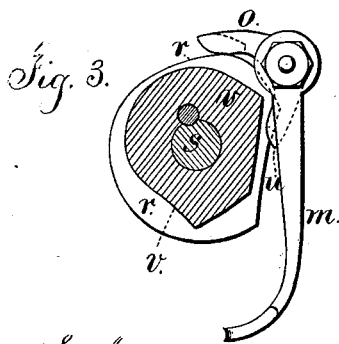
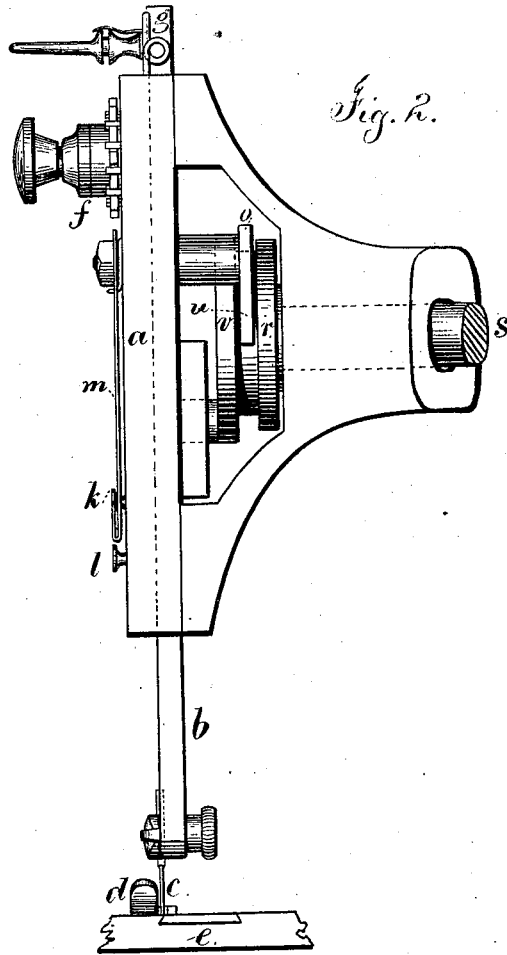
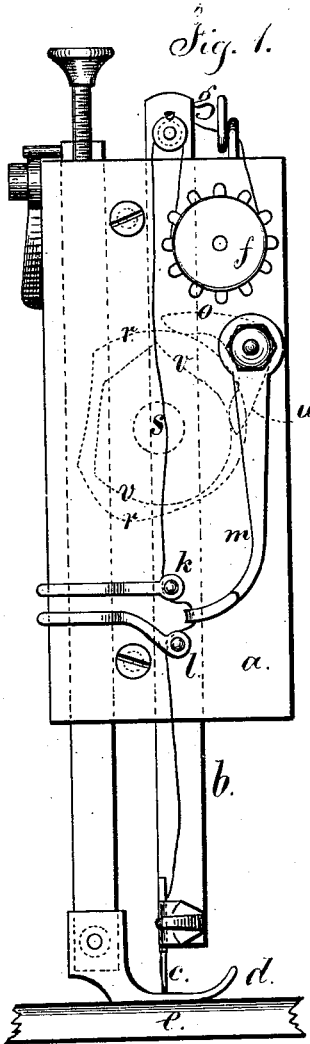

Witnesses,
Chas. H. Smith,
Geo. T. Pinckney

Inventor
John T. Jones
per L. W. Serrell
attly.

UNITED STATES PATENT OFFICE.

JOHN T. JONES, OF ILION, NEW YORK.

IMPROVEMENT IN SEWING-MACHINE TAKE-UPS.

Specification forming part of Letters Patent No. **164,179**, dated June 8, 1875; application filed April 24, 1875.

To all whom it may concern:

Be it known that I, JOHN T. JONES, of Ilion, in the county of Herkimer and State of New York, have invented an Improvement in Sewing-Machine Take-Ups, of which the following is a specification:

The present improvement relates to that portion of the sewing-machine known as the thread-controller. Devices for controlling the thread have been made consisting of a spring-lever and cam, the spring pressing the lever toward the cam, and the cam acting to move the spring-lever and relieve the thread from the tension caused by the spring at the proper times. In machines of this class there is nothing to prevent the inertia of the thread-controlling lever moving the same too far under high speeds, and lifting the arm from the cam against the operation of the spring. This movement is very liable to break the thread by the sudden recoil of the spring-lever, to prevent the proper tightening of the stitch and to draw off thread from the spool at the wrong time and irregularly; and as the thread-controller is moved out by a positive motion, the proper action cannot be obtained on the thread, because there is more slack thread to control when sewing thin material than when sewing thick goods. My present invention is for the purpose of avoiding these difficulties by combining with the spring thread-controlling arm a second cam and arm, acting periodically in the opposite direction, so that during a portion of the movement of the sewing-machine needle the thread-controlling arm yields freely, and allows the thread to yield to inequalities in the fabric or the movement of the shuttle, so that the slack thread will be taken up on any kind of goods, and yet the motion be positive when the stitch is tightened, thereby insuring uniformity in the action of the thread-controller at high as well as low speeds, and insuring perfect sewing regardless of the varying thicknesses of the fabric and of the speed at which the machine is run.

In the drawing, Figure 1 is a front elevation of the head, needle-bar, and thread-controlling mechanism. Fig. 2 is a side view, and Fig. 3 is a skeleton view, illustrative of the position and action of the cams.

The front plate *a*, needle-bar *b*, needle *c*, presser-foot *d*, bed *e*, and actuating mechanism are of any character usual in shuttle sewing-machines.

The tension apparatus *f*, thread-guide *g*, spring-fingers and rollers or guides *k l*, and thread-controlling lever *m* are similar to those set forth in my Patent No. 136,324, and the lever *m* is upon a shaft that passes through the front plate *a*, and is provided with an arm, *o*, that is pressed toward a cam, *r*, upon the actuating-shaft *s* of the sewing-machine by means of a spring similar to that in the aforesaid patent, only the spring acts in the opposite direction.

The second cam *v* is adjacent to the cam *r*, and the second arm *u* is affixed to the shaft of the thread-controlling lever *m*, and acts the other side of said shaft to the arm *o*, so that the arm *o* is always pressed toward the cam *r*, and the thread-controlling lever is yielding in one direction, in the ordinary manner, except when the cam *v*, coming against the arm *u*, renders the lever firm and under the control of the cams independently of the spring; hence, by properly shaping the cam *v*, the thread-controller is made positive when the needle is rising and tightening the stitch.

The shape and position of these cams and arms will, of course, depend upon the peculiar construction of the other parts of the machine.

In Fig. 4 I have shown devices for performing the same operation with one arm. In this instance one cam is within the other, and the groove formed between them is wider in some places than the pin on the arm *t*, so that the arm is controlled by the spring and one cam-surface jointly; but where the slot is the width of the pin on the arm, the movement of the take-up will be positive, and according to the width of the slot, so more or less yielding movement is allowed the thread-controller.

I claim as my invention—

The combination, with the thread-controlling lever *m*, spring-arm *o*, and cam *r*, of a second cam, arranged as described, whereby the thread-controller is caused to act positively and independently of the spring during a portion of the movement, for the purposes and substantially as specified.

Signed by me this 22d day of April, A. D. 1875.

JOHN T. JONES.

Witnesses:

THOS. RICHARDSON,
GEO. O. RASBACH.