

D. LEIBY.

Means for Ventilating and Discharging Bilge-Water  
from Vessels.

No. 164,191.

Patented June 8, 1875.

Fig. 1.

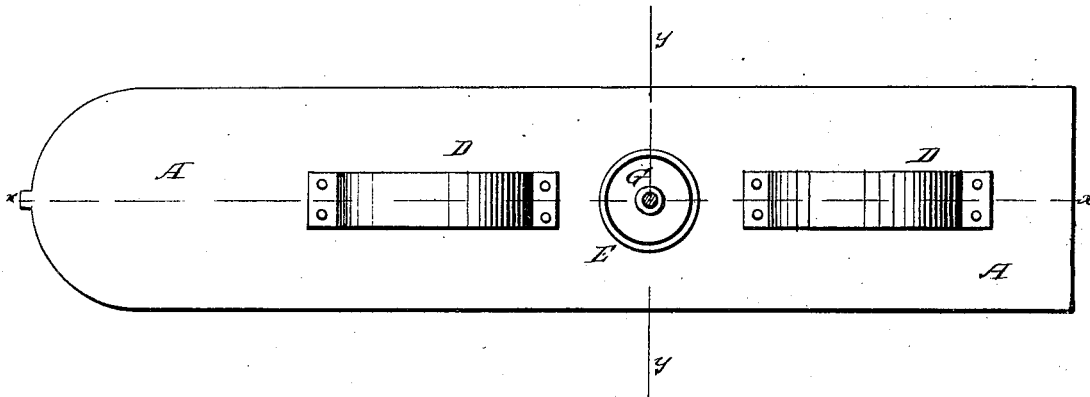

Fig. 2.

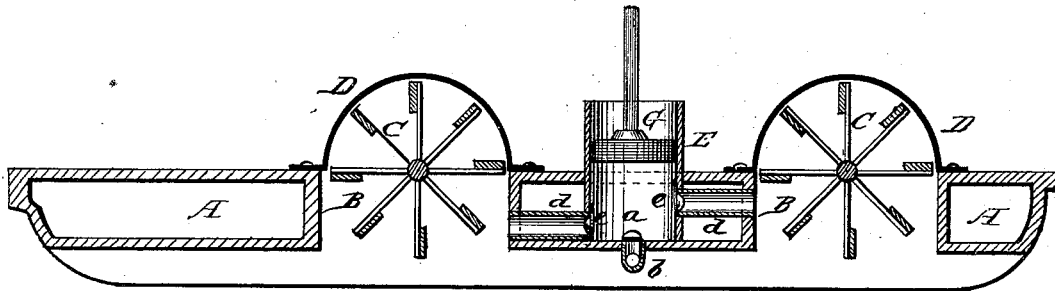
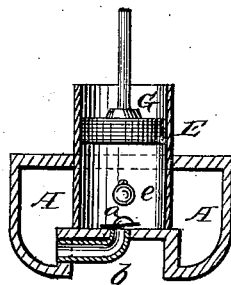

Fig. 3.



WITNESSES:

*P. C. Dietrich*

*H. C. McArthur*

INVENTOR:

*Daniel Leiby*

per *C. H. Watson & Co*  
ATTORNEYS

# UNITED STATES PATENT OFFICE.

DANIEL LEIBY, OF RIVERSIDE, PENNSYLVANIA.

IMPROVEMENT IN MEANS FOR VENTILATING AND DISCHARGING BILGE-WATER FROM VESSELS.

Specification forming part of Letters Patent No. **164,191**, dated June 8, 1875; application filed April 10, 1875.

*To all whom it may concern:*

Be it known that I, DANIEL LEIBY, of Riverside, in the county of Northumberland and State of Pennsylvania, have invented certain new and useful Improvements in Wheel-Vessels; and I do hereby declare that the following is a full, clear, and exact description thereof, which will enable others skilled in the art to which it pertains to make and use the same, reference being had to the accompanying drawings and to the letters of reference marked thereon, which form a part of this specification.

The object of my invention is principally to remove all foul air and bilge-water from vessels; and to this end the nature of my invention consists in providing a vessel with a suitable pump communicating, by a pipe and valve, with the bottom of the vessel, and by other pipes and valves with air-tight casings inclosing the paddle-wheels. It also consists in the construction and combination of parts as will be hereinafter more fully set forth.

In the annexed drawing, Figure 1 is a plan view of a vessel embodying my invention. Fig. 2 is a longitudinal vertical section of the same through the line *x x*, Fig. 1. Fig. 3 is a transverse vertical section through the line *y y*, Fig. 1.

A represents the hull of a vessel provided with two vertical openings, B B, in the longitudinal center of the vessel. In these openings are located the paddle-wheels C C, which may be arranged at any desired height, and they are covered on top by air-tight casings or wheel-houses D D. Between the wheels C C, at any suitable point in the vessel, is a pump-cylinder, E, with reciprocating piston G operated by any convenient means. From the bottom of this pump a pipe, *b*, leads to the interior of the vessel at the bottom, and on

the bottom of the pump is an upward-opening valve, *a*, covering the end of said pipe. The pump-cylinder E is further, by pipes *d d*, connected with the openings B B above the water-line, said pipes being at their inner ends provided with outwardly-opening valves *e e*. The pump being in operation, it draws all the foul air and bilge-water from the interior of the vessel, and discharges the same into the wheel-openings B B, and as the pure air from above at once takes the place of the removed foul air a continuous circulation of air may be kept up through the vessel, so as to perfectly ventilate the same. The casings or wheel-houses D being made air-tight, the air discharged into them by the pump will be more or less compressed, so as to force the water in the openings B downward, and causing it to stand therein below the water-line on the outside, thereby preventing the paddle-wheels from becoming too deeply immersed. This is also of great importance, as it is only the paddles that exert any force to propel the vessel.

Having thus fully described my invention, what I claim as new, and desire to secure by Letters Patent, is—

In a vessel constructed substantially as described, the combination of a pump, E G, the pipe *b*, with valve *a* communicating with the bottom of a vessel, and the pipes *d d*, with valves *e e* communicating with the wheel-houses thereof, as and for the purposes herein set forth.

In testimony that I claim the foregoing as my own I affix my signature in presence of two witnesses.

DANIEL LEIBY.

Witnesses:

C. H. WATSON,  
H. A. HALL.