

D. E. PARIS.
Torsion-Springs for Vehicles.

No. 164,202.

Patented June 8, 1875.

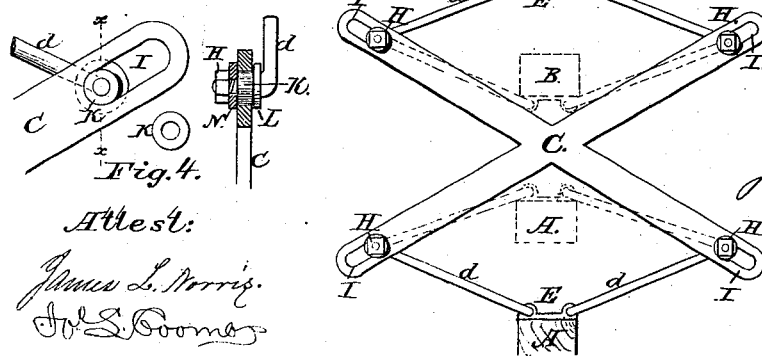
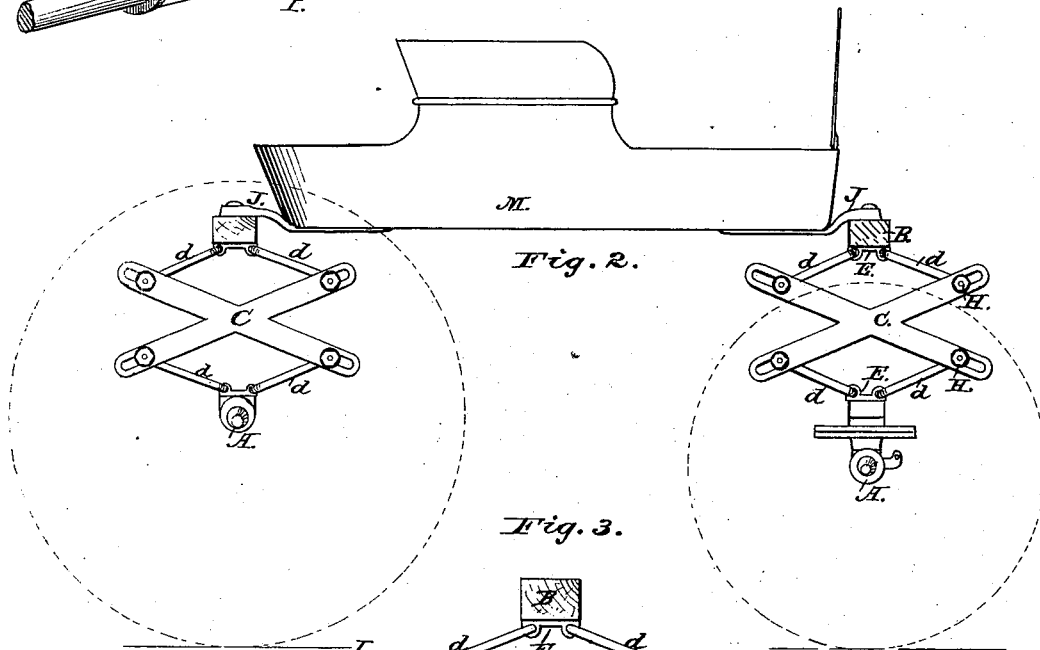
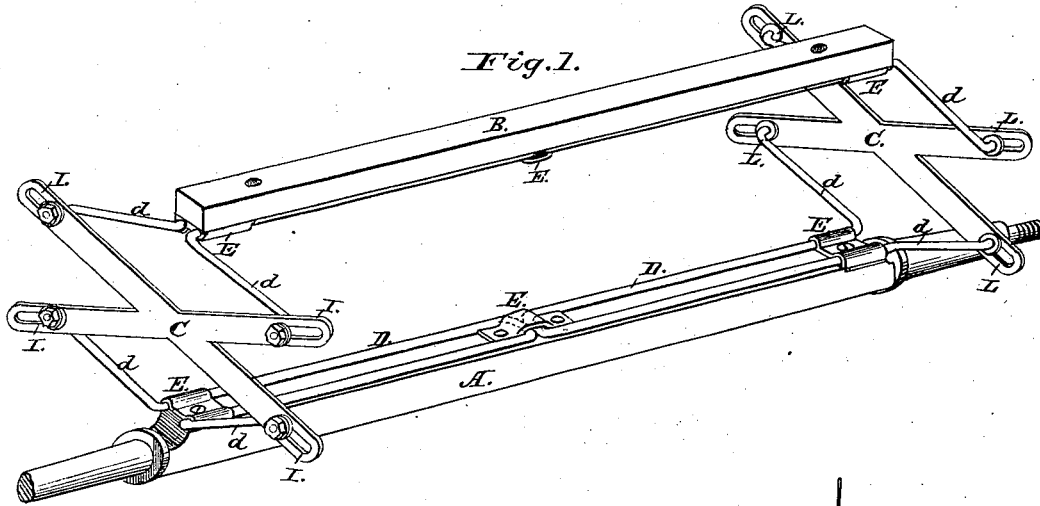

Inventor.

David Eldon Paris

Attest:

James L. Norris
John S. Boone

D. E. PARIS.
Torsion-Springs for Vehicles.

No. 164,202.

Patented June 8, 1875.

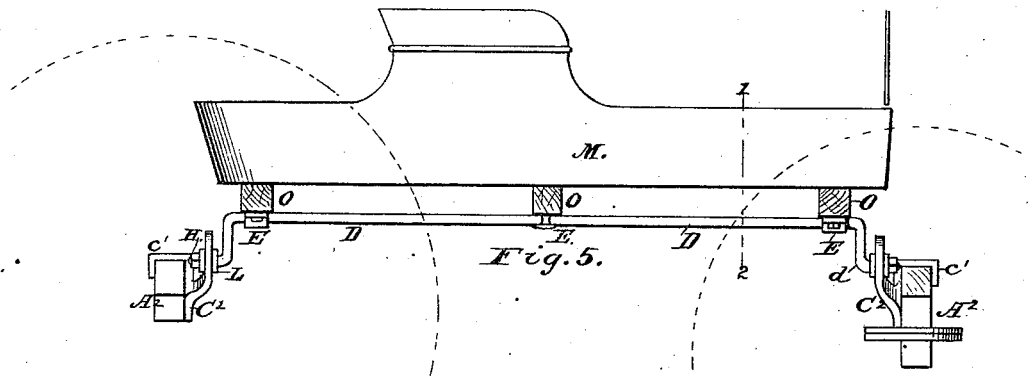

Fig. 6.

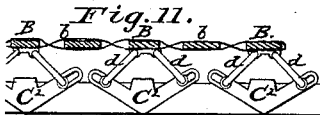
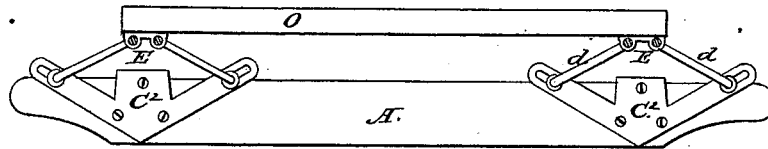

Fig. 7.

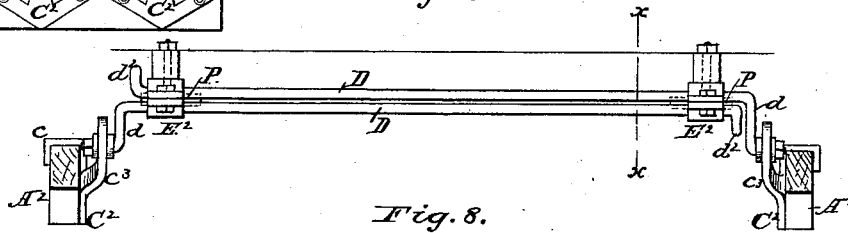

Fig. 8.

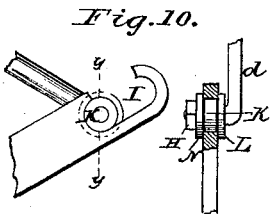

Fig. 10.

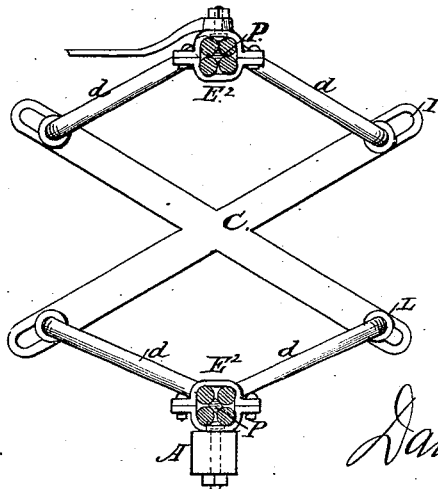

Fig. 9.

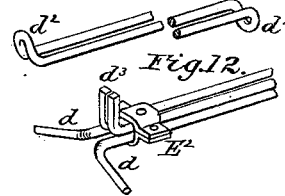

Fig. 12.

Attest:

James L. Norris.
Joe S. Doombs.

Inventor:

Daniel Eldon Paris

UNITED STATES PATENT OFFICE.

DANIEL E. PARIS, OF TROY, NEW YORK.

IMPROVEMENT IN TORSION-SPRINGS FOR VEHICLES.

Specification forming part of Letters Patent No. **164,202**, dated June 8, 1875; application filed May 20, 1875.

To all whom it may concern:

Be it known that I, DANIEL E. PARIS, of Troy, in the county of Rensselaer and State of New York, have invented certain new and useful Improvements in Springs for Carriages, Cars, and other Vehicles, of which the following is a specification:

The object of my invention is to utilize and make available the torsional principle in steel springs; and it consists in providing means by which a rod of steel or iron is twisted evenly and perfectly.

The accompanying drawing forms a part of this specification.

Figure 1 is a perspective view of my completed double spring, showing its position on the wagon-axle. Fig. 2 is an end view of the springs, as applied to a common road-wagon. Fig. 3 is the same view as Fig. 2, showing the motion of the springs as they shut down toward each other, when loaded. Fig. 4 shows the slot, friction-wheel, nut, and washer that I use on each of the four outer points of the springs. Fig. 5 shows another mode of attaching the springs to the wagon-box, and also to the axle, and in this mode only half the spring is used, *i. e.*, a single spring. Fig. 6 is an end view of the spring shown in Fig. 5. Fig. 7 is a modification of my invention, inasmuch as the spring is made wholly of metal, no wood being necessary. This figure shows only half the spring; but Fig. 8 shows the double spring constructed in this manner, it being an end view of the same. Fig. 9 shows the farther or rear end of each spring or sets of springs, the one being turned up, the other down. (Seen again in Fig. 7.) Fig. 10 is a modification of the invention shown in Fig. 9, inasmuch as each part of the spring is separate and held by a double clip. Fig. 11 shows how the spring, as made single, (shown in Figs. 5 and 6,) may be adapted to bed-springs or bed-bottoms.

A represents the ordinary axle to a wagon; B, the ordinary top cap to an elliptic spring, to which the ordinary connecting-rods or supports J J (seen in Fig. 2) are attached.

It will be seen, therefore, that these springs take the place of the ordinary elliptic spring. When the springs are shut downward, so that the arms *d d* are horizontal, all the power

heretofore secured by other springs is obtained, and even more, for my springs are so constructed that they can be used double, which I believe has not been done heretofore in any practicable shape; but when the arms *d d* are horizontal not one quarter of the power of my springs is obtained, because the torsional action, as they move toward each other, as shown by the dotted lines in Fig. 3, becomes very great, and the power of resistance is increased many times after the arms *d d* pass the horizontal line, as above mentioned.

The equalizing-bar C is constructed in the form of the letter X, turned down on its side; but if greater torsion be required the form should be that of the letter X in its natural position.

It is not important, however, that this equalizing and connecting bar or yoke should be in the form of the letter X. That form seems to be preferable, and yet a square piece of metal containing the four slots I I I I is equally serviceable, though inferior in looks and appearance.

I prefer the slots I I I I to incline inward, as shown in the figures—that is, they are best in the shape of an inclined plane, because the arms *d d* spread outward at their extremities under pressure on the spring D, and this motion continues outward until the arms *d d* become horizontal, after which the motion is again inward toward the center. The first motion, when the load is lightest, is up the inclined plane. The second motion, when the load is heaviest, is down the inclined plane. Thus the shape of the slot assists the action of the spring when assistance is needed under heavy pressure.

To keep the spring from working out of place sidewise I attach a washer (seen at L in Figs. 1 and 4) to the arms *d d*, and also another. (Seen at N in Fig. 4.) The nut H is screwed onto the arms *d d* upon the washer N, holding the whole firmly in position in the slot I and on the bar or yoke C, as above described. I use a roller on the arms *d d*. (Seen at K in Fig. 4, and also at K in Fig. 10.) This roller plays in the slot I, and takes away the friction, and makes the spring last longer and work easier.

The modifications shown in Figs. 5 and 6 are no wise altered in principle, but in adaptation to road and lumber wagons they form an important element of my invention.

Heretofore torsion-springs have been used, being placed on the bolster of a wagon, and lengthwise with it; but I place them lengthwise with the wagon-box, merely attaching the yokes C² C² to the bolster or axle, and attaching the springs themselves to the cross-bars O O O. (Seen in Fig. 5.) These cross-bars go entirely across the bottom of the wagon-box, or they may go only part way across, as desired; and they may be large or small. If they are small, the torsional action of the spring will be diminished; if large, increased, inasmuch as the larger they are the greater will be the depression of the springs before the box M will come in contact with the bolster or axle A²; but in case of any great increase in the depth of the bars O O O the slots I I would have to be extended downward and inward, so that the arms *d d* could move downward and inward until the wagon-box M, or its equivalent, should strike the bolster A².

It will be seen that the equalizing bar or yoke C², in Figs. 5 and 6, represents only one-half of the bar C of Figs. 1 and 2; and again, while the bar C is attached to nothing save the spring itself, yet the modification shown in Figs. 5 and 6, where the spring is single instead of double, requires different adjustment, and a somewhat different construction. I hook it over the bolster A², as seen at C¹ in Fig. 5, or simply screw it to the bolster, as seen in Fig. 6; but in either case the arms of the bar or yoke C² are bent or turned inward, as seen at C³ in Fig. 7, so that the nut H shall not strike the bolster or axle as it plays up and down the slot I of the yoke.

This construction of spring I use for bed-bottoms, as seen in Fig. 11, merely running the bars that lie on the springs lengthwise with them, as in Fig. 1; and in order to have a more continuous bottom, smoother, and more even, I attach the springs, as they are repeated, together by a wire, so that the strain will be on all, and I fill up the places between the springs by an extra slat or piece, *b*. (Seen in Fig. 11.)

In order to make a longer spring, which shall work easily and in some places, I prefer to make the spring entirely of metal, as seen in Figs. 7 and 8. In this style of spring I bring the wires or rods composing it together, side by side, so that they run closely parallel to each other, as seen in side view in Fig. 7 and end view in Fig. 8.

When so constructed, they are held together by the double clip E², (seen in Figs. 7, 8, and 12,) and inside of the four rods within this clip, and at each end of the spring, I insert the friction-rod or place-guard P. (Seen in Figs. 7 and 8.) This guard should conform to the curve of the rods, so as to assist them to roll true and even. I add to the strength

of this style of spring by turning up the ends, as seen at *d*², Figs. 7 and 9. This prevents the spring from breaking where it is bent or turned at the center, but it is not necessary that it be bent at the center.

Each spring may be in two parts, if desired, under this form of construction, as seen at *d*³ in Fig. 12, and on some accounts it is better that each spring be made in two parts, so that if one part should break or wear out it could be replaced at small expense; but in case the spring be made in two parts the up-turned part (seen at *d*³ in Fig. 12) must be turned in the opposite direction from the arms *d d*, for otherwise the torsion would open them, instead of pressing them against each other; and it is better, too, that the ends be flattened or squared, as seen in Fig. 12, so as to prevent them from passing each other in use.

The slot I in the connecting-yoke C may be open at the top, if preferred, as seen in Fig. 10. This would allow the spring, and whatever was attached to it, to be removed without disturbing the yoke from its place, which might be desirable when the latter is screwed or attached to the bolster of a wagon.

Having thus described my invention, what I claim, and desire to secure by Letters Patent, is—

1. The combination, with the outwardly-projecting arms of torsional springs and their connecting-bar, of the equalizing or connecting yokes, the connecting-bar being of a length less than the distance between the connecting-yokes, whereby the said connecting-bar is adapted to pass down between the connecting-yokes and cause the outwardly-projecting arms to pass beyond their horizontal position, as set forth.

2. An equalizing-plate or connecting-yoke having slotted openings to receive the arms of torsional springs, and constructed with a laterally-projecting supporting-flange, substantially as described, for suspending the springs upon the bolster or axle of a vehicle, as set forth.

3. An equalizing plate or yoke constructed with inclined slots, in combination with the projecting arms of a torsional spring, substantially as described, whereby the arms move upwardly as the spring is pressed downwardly.

4. The combination of a double-slotted equalizing-bar or connecting-yoke with the outwardly-projecting arms of a double torsional spring.

5. An equalizing plate or yoke constructed with an opening to admit of the ready attachment and detachment of the arms of a torsional spring.

6. In combination with the arms of a torsional spring and their supporting and connecting plate, a washer, arranged on said arms, for limiting and regulating the motion of the arms in their bearings.

7. A torsional spring composed of two parallel bars connected at one end by a loop

turned upward or downward, for resisting and preventing separation or breaking.

8. The combination, in a torsional spring, of two separate parallel bars or rods turned in a direction opposite that of the arms, so that they will press against each other as the two arms of the spring are turned outward.

In testimony that I claim the foregoing I have hereunto set my hand.

DANL. ELDON PARIS.

Witnesses:

JAMES L. NORRIS,
JOS. L. COOMBS.