

M. TANDY.  
Soldering-Clamp.

No. 164,232.

Patented June 8, 1875.

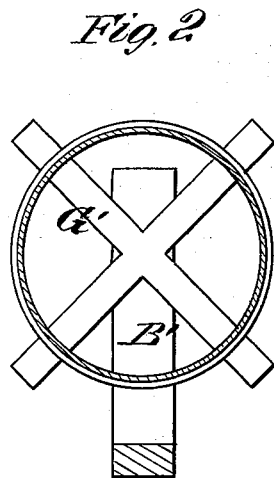
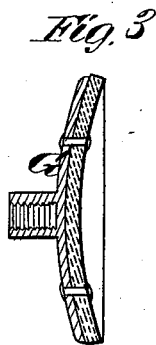
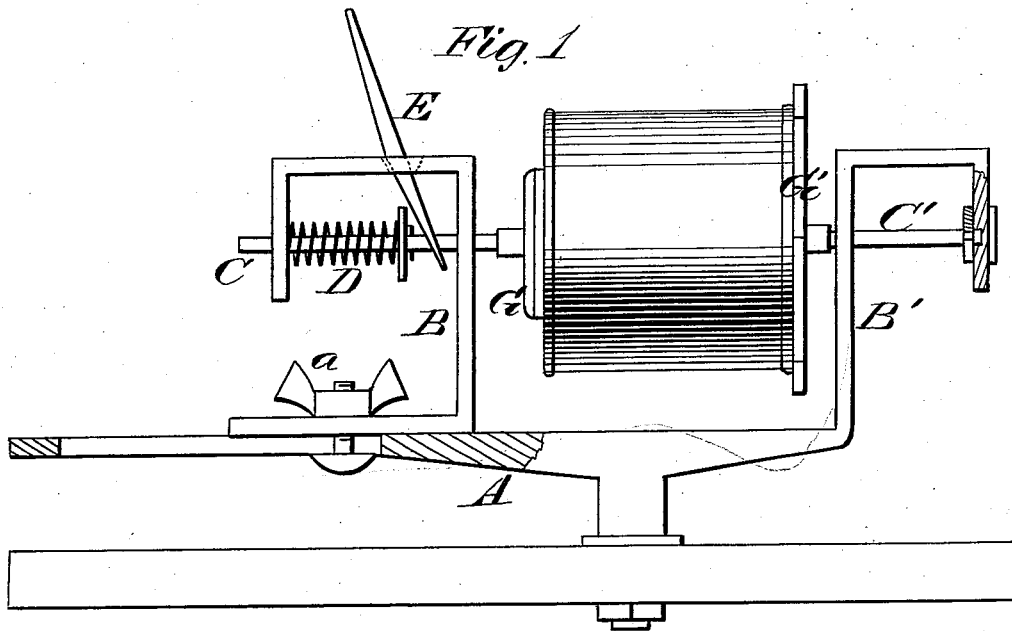

WITNESSES

*Geo. C. Upham,*  
*A. T. Crane*

INVENTOR

*Mart Tandy,*  
*Chipman & Co.*

ATTORNEYS

# UNITED STATES PATENT OFFICE.

MARK TANDY, OF DALLAS CITY, ILLINOIS, ASSIGNOR OF ONE-HALF HIS  
RIGHT TO B. MENDENHALL, OF SAME PLACE.

## IMPROVEMENT IN SOLDERING-CLAMPS.

Specification forming part of Letters Patent No. **164,232**, dated June 8, 1875; application filed  
December 5, 1874.

*To all whom it may concern:*

Be it known that I, MARK TANDY, of Dallas City, in the county of Hancock and State of Illinois, have invented a new and valuable Improvement in Soldering-Clamps; and I do hereby declare that the following is a full, clear, and exact description of the construction and operation of the same, reference being had to the annexed drawings making a part of this specification, and to the letters and figures of reference marked thereon.

Figure 1 of the drawing is a representation of a front elevation of my soldering-clamp, and Fig. 2 is a transverse vertical sectional view of the same. Fig. 3 is a sectional detail view.

This invention has relation to means for holding tinware while soldering the same; and it consists in the employment of clamp-disks, between which to hold the vessels, which clamps are allowed to turn freely about their axes, and are applied in a frame, which is adjustable for large and small vessels, as will be understood from the following description.

In the annexed drawings, A designates the frame of the machine, which consists of a horizontal portion, rising from which are two standards, B B'. The standard B is adjustable in a direction with the length of the horizontal portion of the frame A, and is rigidly confined in its place by means of a clamp-nut, *a*. C C' designate two horizontal shafts, which have their bearings in the standards B B', and which are allowed to rotate about their axes. The shaft C has coiled around it a spring, D, which is compressed between a limb of standard B and a collar on said shaft. G designates a circular clamp, which is secured on one end of the shaft C, and con-

structed with a concave face, which is preferably covered with india-rubber, as indicated in the sectional view, Fig. 3. G' designates a clamp, which is designed for tin cups and other hollow-ware, and which consists of four radial arms long enough to bear upon the edges of the vessels. This clamp G' is secured on one end of the shaft C', and turns with this shaft.

For fruit-cans and other vessels having both ends closed the clamp G' will be removed, and a clamp like the one on shaft C substituted.

When the standard B is properly adjusted for a vessel of a given size, the operator forces back the shaft C by means of a lever, E, and adjusts a vessel centrally between the two clamps G G'. He then releases the shaft C, and allows the spring D to act in retaining the vessel in its place. It will thus be seen that the vessel, while clamped in the machine, can be rotated about its axis during the operation of soldering it.

What I claim as new, and desire to secure by Letters Patent, is—

In a machine for holding cans, the adjustable frame B, carrying the lever E, shaft C, clamp G, spring D, and clamping device *a*, in combination with the slotted frame A, carrying the shaft C' and clamp G', substantially as described.

In testimony that I claim the above I have hereunto subscribed my name in the presence of two witnesses.

M. TANDY.

Witnesses:

B. MENDENHALL,  
C. W. LEHMAN.